

Cabling and Pinout Information

This appendix contains pinout information for CDDI A/B ports, CDDI adapter ports, concentrator master ports, and the optical bypass switch connector.

CDDI Cabling

MLT-3 is the new American National Standards Institute (ANSI) draft specification developed by Cisco Systems for compression of FDDI signals over UTP copper wire. Cisco Systems products that are upgraded to MLT-3 will interoperate with other vendors' equipment that complies with the draft standard.

Workgroup CDDI/MLT-3 installations require category 5 equipment throughout. Two types of category 5 modular cables—cross-connect and straight-through—are used to connect concentrators and adapters to the network. (See Figure B-1 and Figure B-2.)

Note MLT-3 equipment can only be connected to other MLT-3 equipment.

Figure B-1, Figure B-2, and Figure B-3 illustrate the EIA/TIA-568B wiring standard and CDDI transmit and receive pairs.

Figure B-1 Cross-Connect Cable Pinout

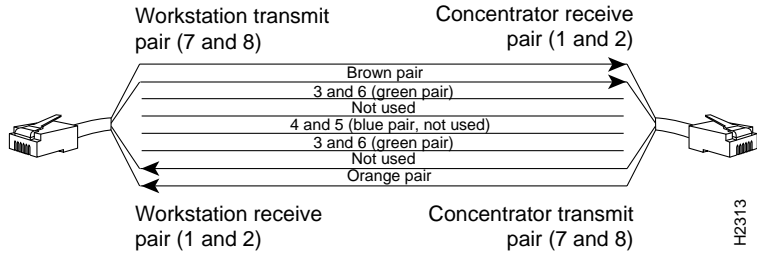

Figure B-2 Straight-Through Cable Pinout

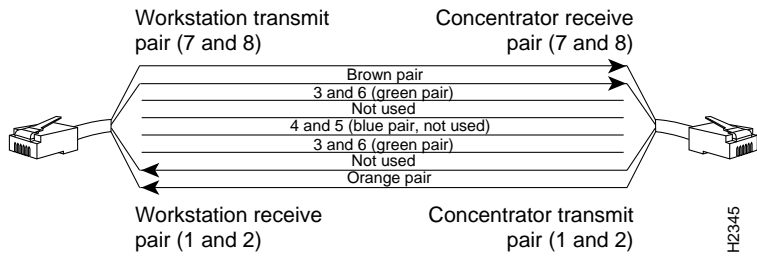

Figure B-3 Patch-Panel Connections

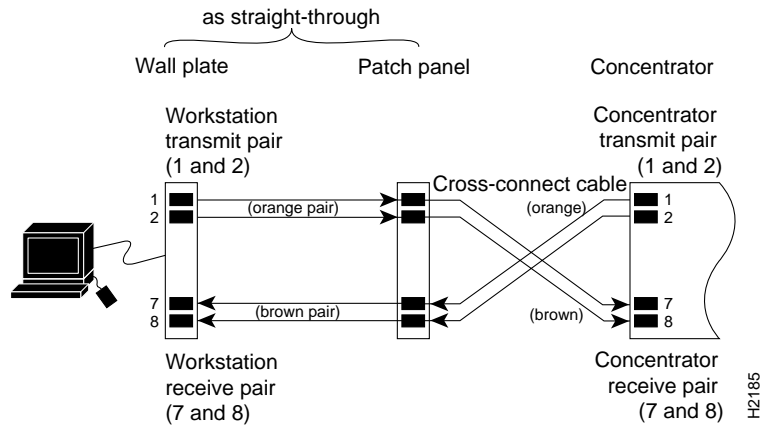
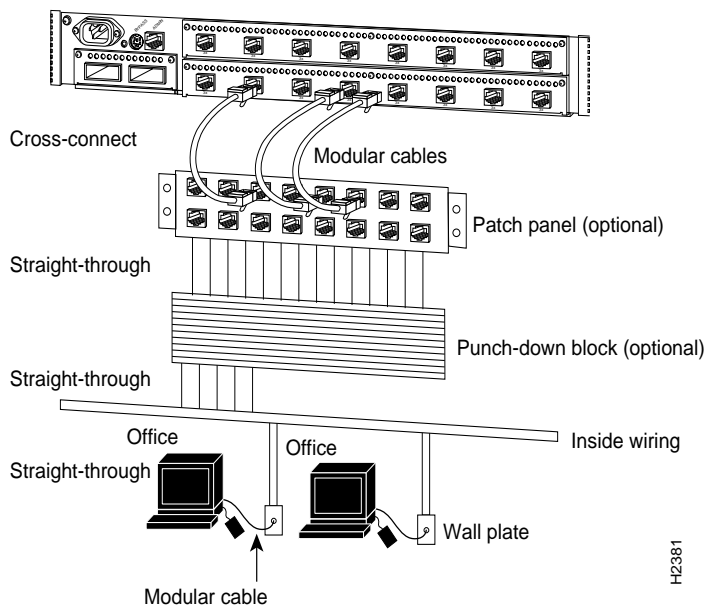

Figure B-4 shows the location of straight-through and cross-connect cabling for CDDI installations. Note that the cross-connect cabling is used between the concentrator and the patch panel.

Figure B-4 Straight-Through and Cross-Connect Cabling



H2381

Bypass Connector Pinouts

Figure B-5 shows the optical bypass switch connector pinouts.

Figure B-5 Bypass Connector Pinouts

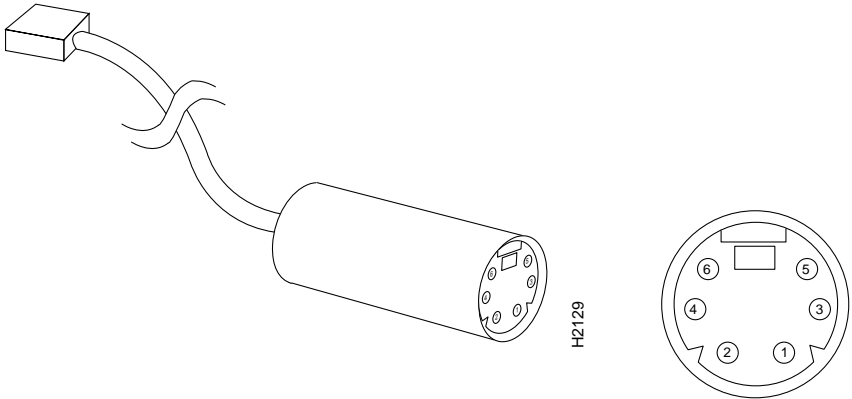

| Pin | Function |
|-----|---------------|
| 1 | V+ |
| 2 | |
| 3 | Switch |
| 4 | |
| 5 | Ground |
| 6 | Bypass switch |

H2082

Bypass Connector Pinouts
