

# Quick Reference FOR CISCO 7206 INSTALLATION

These installation tasks should be completed in the following order:

- 1 Rack-mounting the router
- 2 Connecting cables to the router
- 3 Starting the router

For detailed instructions about rack-mounting, cabling, and starting the Cisco 7206, refer to the publication *Cisco 7206 Installation and Configuration Guide* and the port adapter configuration notes that shipped with your router.

Cisco 7200 series documentation and additional literature are available in a CD-ROM package, which ships with your router.

You can also access Cisco product documentation on the World Wide Web at <http://www.cisco.com>.

1

## Rack-mounting the Router

The Cisco 7206 chassis mounts to two rack posts with two rack-mount brackets that attach to either the front or rear sides of the chassis. If you plan to use the cable-management brackets in your rack-mount installation, you must install the cable-management brackets when you install the rack-mount brackets on the chassis.



**Warning** Because of the weight of the chassis, do not attempt to rack-mount the router alone. Have another person assist you.



- Step 1** Install the rack-mount and cable-management brackets to either the front or rear sides of the chassis using a No. 2 Phillips screwdriver and eight M4x8mm Phillips flathead screws.

Installing brackets on the chassis

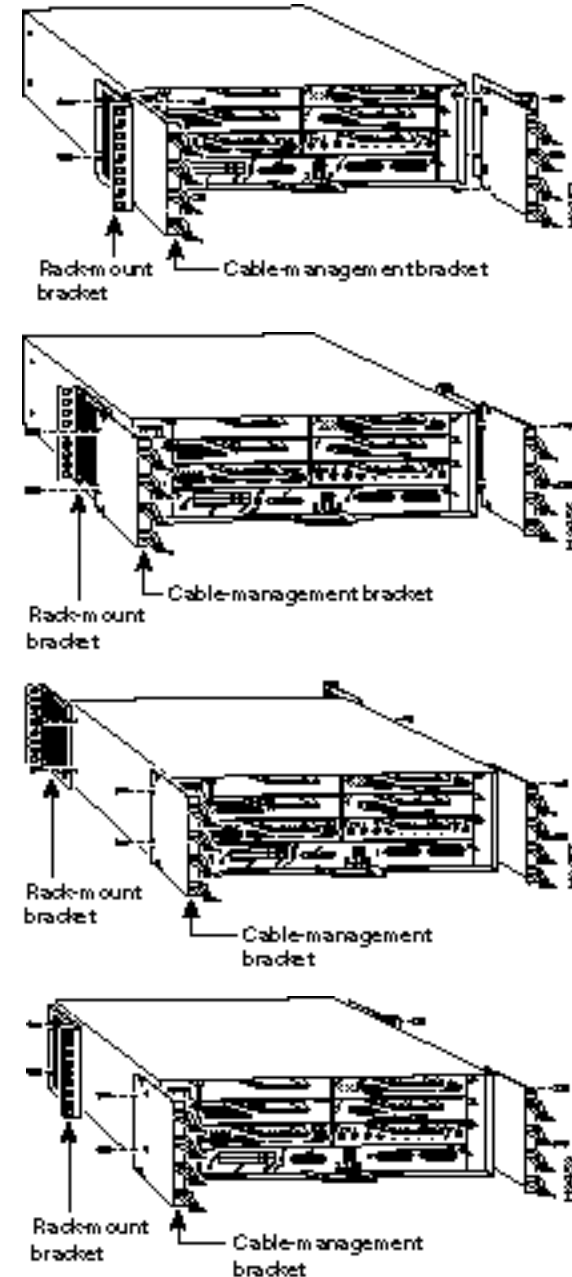

- Step 2** With help from another person, mount the router in the rack using a flat-blade screwdriver and six 10-32 x 3/8 slotted binderhead screws.

Mounting the router in the rack

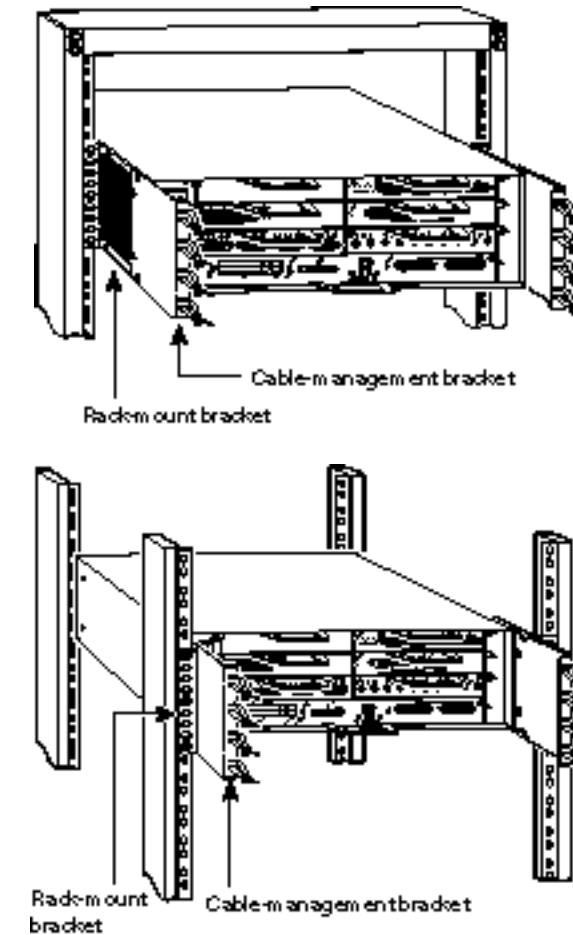

2

## Connecting Cables



**Caution** To provide proper grounding, always connect the cables to your router first.

- Step 1** Connect network interface cables to port adapters installed in the router.

Cabling 10BASE-T Ethernet (4 or 8 ports) interfaces



Cabling 10BASE-FL Ethernet interfaces

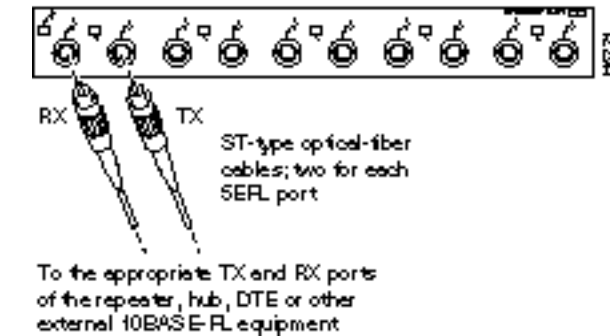

Cabling synchronous serial interfaces

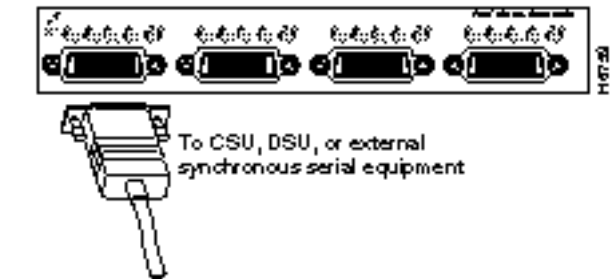

Uses DB-60 connectors.

Cabling Token Ring interfaces

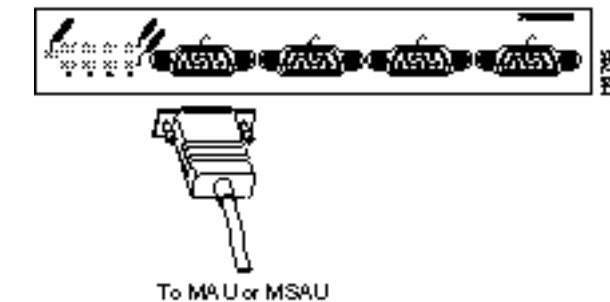

Uses DB-9 connectors.

### Cabling Fast Ethernet 100BASE-TX interfaces

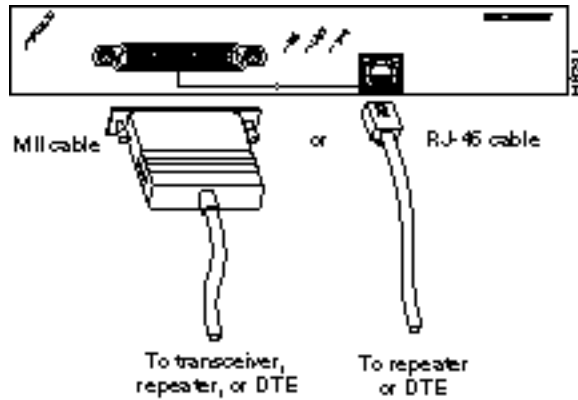

### Cabling Fast Ethernet 100BASE-FX interfaces

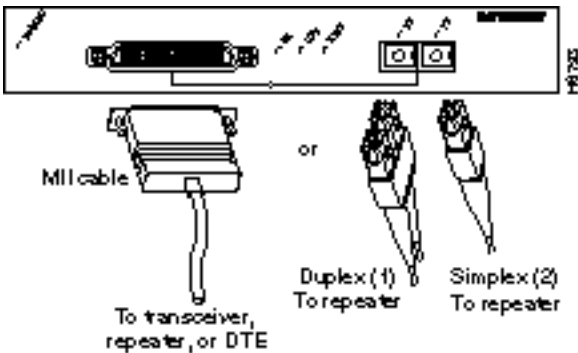

SC-type connectors are used with optical fiber.

### Cabling multimode FDDI interfaces

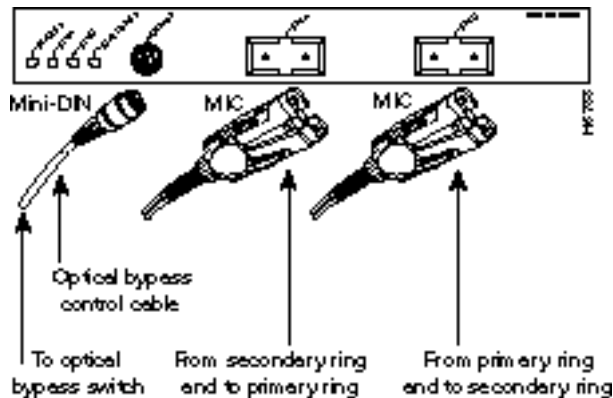

### Cabling single-mode FDDI interfaces

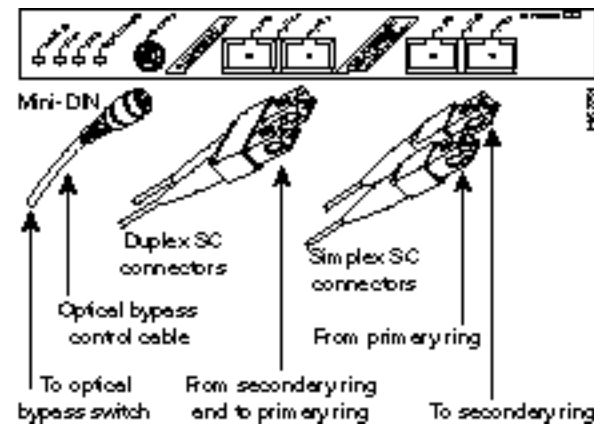

Either duplex or simplex SC-type connectors can be used.

The Cisco 7206 supports additional network interfaces such as ATM, ISDN—PRI and BRI, HSSI, and Channelized E1 and T1. Refer to the *Cisco Product Catalog* for a complete list of network interface types supported by the Cisco 7206.

**Step2** Connect Fast Ethernet, console, and auxiliary cables to the I/O controller.

### Cabling the I/O Controller

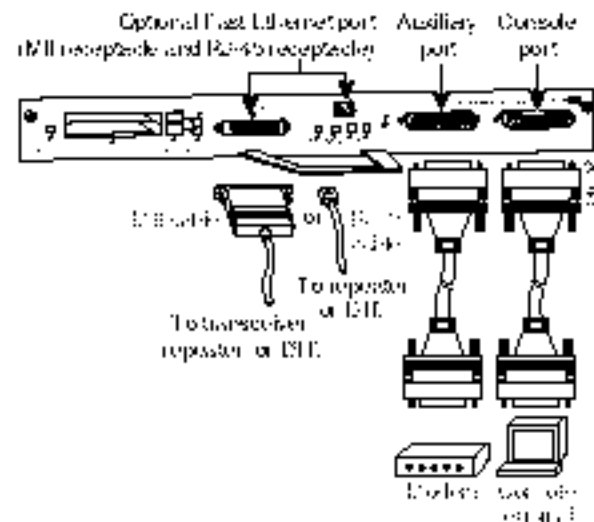

The I/O controller Fast Ethernet port is optional.

**Step3** Connect input power to the router.

The Cisco 7206 supports up to two 280W, AC-input or DC-input power supplies. The following illustration shows the AC-input power cable. Refer to the *Cisco 7206 Installation and Configuration Guide* for DC-input power supply cabling instructions.

### Cabling the AC-input Power Supply

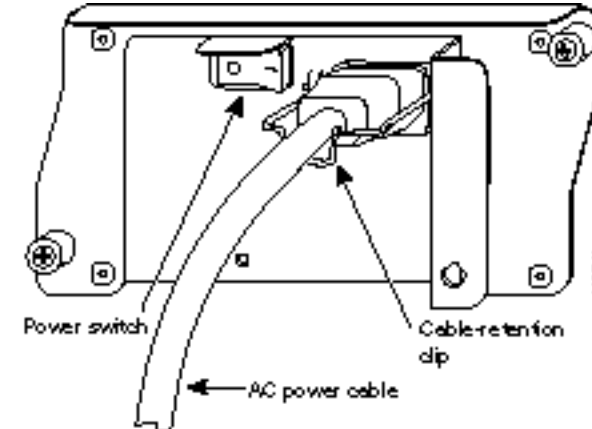

Secure the cable with the cable-retention clip.

3

## Starting the router

**Step1** Place the power switch on each installed power supply in the ON (I) position. The green OK LED on each power supply comes on, and the fans begin operating.

**Step2** Observe I/O controller LEDs.

### I/O Controller LEDs

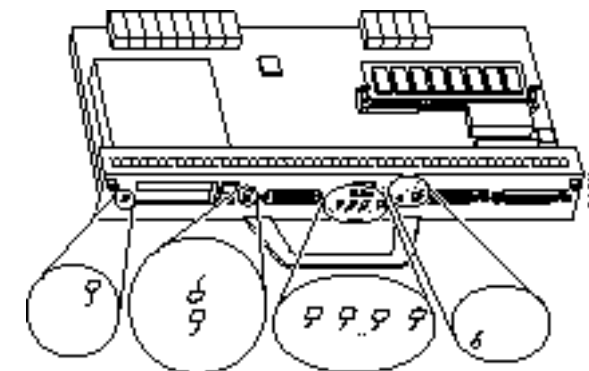

Following are I/O controller LED indications:

- IO Power OK—indicates the I/O controller is receiving power. ON during boot-up.
- Enabled LED—indicates the I/O controller is operational. ON during boot-up.
- Slot LEDs—indicate Flash card activity. Might be ON during boot-up.
- Fast Ethernet port LEDs (if present). ON after power-up.
  - FE Enable—indicates the port is operational.
  - FE Link—indicates the port has established a valid link with the network. ON to indicate network activity on the port.
  - MII EN—indicates the port's MII receptacle is operational (after being configured as the port's media type).
  - RJ45 EN—indicates the port's RJ-45 receptacle is operational (the port's default media type).
  - RJ45 LINK—indicates the port's RJ-45 receptacle has established a valid link with the network. ON to indicate network activity on the port through the RJ-45 receptacle.

Many of the port adapter LEDs will not go on until you have configured their interfaces. If you do not hear the fans operating or you do not get the LED indications shown above after applying power to the router, refer to the chapter "Troubleshooting the Installation" in the *Cisco 7206 Installation and Configuration Guide* for helpful troubleshooting procedures. If you continue to have startup problems after attempting the troubleshooting procedures, obtain technical assistance.

Corporate Headquarters  
Cisco Systems, Inc.  
170 West Tasman Drive  
San Jose, CA 95134-1706  
USA  
<http://www.cisco.com>

