



Cisco 6260 Hardware Installation Guide

Corporate Headquarters

Cisco Systems, Inc.
170 West Tasman Drive
San Jose, CA 95134-1706
USA
<http://www.cisco.com>
Tel: 408 526-4000
800 553-NETS (6387)
Fax: 408 526-4100



THE SPECIFICATIONS AND INFORMATION REGARDING THE PRODUCTS IN THIS MANUAL ARE SUBJECT TO CHANGE WITHOUT NOTICE. ALL STATEMENTS, INFORMATION, AND RECOMMENDATIONS IN THIS MANUAL ARE BELIEVED TO BE ACCURATE BUT ARE PRESENTED WITHOUT WARRANTY OF ANY KIND, EXPRESS OR IMPLIED. USERS MUST TAKE FULL RESPONSIBILITY FOR THEIR APPLICATION OF ANY PRODUCTS.

THE SOFTWARE LICENSE AND LIMITED WARRANTY FOR THE ACCOMPANYING PRODUCT ARE SET FORTH IN THE INFORMATION PACKET THAT SHIPPED WITH THE PRODUCT AND ARE INCORPORATED HEREIN BY THIS REFERENCE. IF YOU ARE UNABLE TO LOCATE THE SOFTWARE LICENSE OR LIMITED WARRANTY, CONTACT YOUR CISCO REPRESENTATIVE FOR A COPY.

The Cisco implementation of TCP header compression is an adaptation of a program developed by the University of California, Berkeley (UCB) as part of UCB's public domain version of the UNIX operating system. All rights reserved. Copyright © 1981, Regents of the University of California.

NOTWITHSTANDING ANY OTHER WARRANTY HEREIN, ALL DOCUMENT FILES AND SOFTWARE OF THESE SUPPLIERS ARE PROVIDED "AS IS" WITH ALL FAULTS. CISCO AND THE ABOVE-NAMED SUPPLIERS DISCLAIM ALL WARRANTIES, EXPRESSED OR IMPLIED, INCLUDING, WITHOUT LIMITATION, THOSE OF MERCHANTABILITY, FITNESS FOR A PARTICULAR PURPOSE AND NONINFRINGEMENT OR ARISING FROM A COURSE OF DEALING, USAGE, OR TRADE PRACTICE.

IN NO EVENT SHALL CISCO OR ITS SUPPLIERS BE LIABLE FOR ANY INDIRECT, SPECIAL, CONSEQUENTIAL, OR INCIDENTAL DAMAGES, INCLUDING, WITHOUT LIMITATION, LOST PROFITS OR LOSS OR DAMAGE TO DATA ARISING OUT OF THE USE OR INABILITY TO USE THIS MANUAL, EVEN IF CISCO OR ITS SUPPLIERS HAVE BEEN ADVISED OF THE POSSIBILITY OF SUCH DAMAGES.

CCIP, the Cisco Arrow logo, the Cisco *Powered* Network mark, the Cisco Systems Verified logo, Cisco Unity, Follow Me Browsing, FormShare, iQ Breakthrough, iQ Expertise, iQ FastTrack, the iQ Logo, iQ Net Readiness Scorecard, Networking Academy, ScriptShare, SMARTnet, TransPath, and Voice LAN are trademarks of Cisco Systems, Inc.; Changing the Way We Work, Live, Play, and Learn, Discover All That's Possible, The Fastest Way to Increase Your Internet Quotient, and iQuick Study are service marks of Cisco Systems, Inc.; and Aironet, ASIST, BPX, Catalyst, CCDA, CCDP, CCIE, CCNA, CCNP, Cisco, the Cisco Certified Internetwork Expert logo, Cisco IOS, the Cisco IOS logo, Cisco Press, Cisco Systems, Cisco Systems Capital, the Cisco Systems logo, Empowering the Internet Generation, Enterprise/Solver, EtherChannel, EtherSwitch, Fast Step, GigaStack, Internet Quotient, IOS, IP/TV, LightStream, MGX, MICA, the Networkers logo, Network Registrar, *Packet*, PIX, Post-Routing, Pre-Routing, RateMUX, Registrar, SlideCast, StrataView Plus, Stratm, SwitchProbe, TeleRouter, and VCO are registered trademarks of Cisco Systems, Inc. and/or its affiliates in the U.S. and certain other countries.

All other trademarks mentioned in this document or Web site are the property of their respective owners. The use of the word partner does not imply a partnership relationship between Cisco and any other company. (0208R)

Cisco 6260 Hardware Installation Guide

Copyright © 2002, Cisco Systems, Inc.
All rights reserved.



Preface **xiii**

- Audience **xiii**
- Purpose **xiii**
- Organization **xiii**
- Conventions **xiv**
- Related Documentation **xv**
- Obtaining Documentation **xvi**
 - World Wide Web **xvi**
 - Documentation CD-ROM **xvi**
 - Ordering Documentation **xvi**
 - Documentation Feedback **xvi**
- Obtaining Technical Assistance **xvii**
 - Cisco.com **xvii**
 - Technical Assistance Center **xvii**
 - Contacting TAC by Using the Cisco TAC Website **xvii**
 - Contacting TAC by Telephone **xviii**

CHAPTER 1

Product Overview **1-1**

- 1.1 Introduction to the Cisco 6260 System **1-1**
 - 1.1.1 Features **1-3**
 - 1.1.2 Configurations **1-3**
 - 1.1.2.1 Cisco 6260 System with a POTS Splitter Configuration **1-4**
 - 1.1.2.2 Cisco 6260 System Without a POTS Splitter Configuration **1-4**
 - 1.1.2.3 IMA Configuration **1-4**
 - 1.1.2.4 Subtended Network Configuration **1-6**
- 1.2 Cisco 6260 System Overview **1-10**
 - 1.2.1 Cisco 6260 Card Compartment **1-10**
 - 1.2.2 Cisco 6260 Connectors **1-12**
 - 1.2.3 Cisco 6260 Cards **1-13**
 - 1.2.3.1 Quad-Port DMT ATU-C Line Card Overview **1-13**
 - 1.2.3.2 Quad-Port DMT ATU-C over ISDN Line Card Overview **1-15**
 - 1.2.3.3 Quad-Port Flexi ATU-C Line Card Overview **1-17**
 - 1.2.3.4 Quad-Port STU-C Line Card Overview **1-19**
 - 1.2.3.5 Octal-Port DMT ATU-C Line Card Overview **1-21**

- 1.2.3.6 Octal-Port DMT ATU-C Over ISDN Line Card Overview **1-23**
- 1.2.3.7 Octal-Port G.SHDSL SHTU-C Line Card Overview **1-25**
- 1.2.3.8 Line Card Intermixing **1-27**
- 1.2.3.9 DS3/2DS3 NI-2 Card Overview **1-30**
- 1.2.3.10 DS3+T1/E1 IMA NI-2 Card Overview **1-32**
- 1.2.3.11 OC-3c/OC-3c NI-2 Card Overview **1-35**
- 1.2.3.12 Network Clocking Overview **1-39**
- 1.2.3.13 Redundancy Overview **1-39**
- 1.2.3.14 Redundancy in Subtended Configurations **1-41**
- 1.2.4 Cisco 6260 I/O Modules **1-41**
 - 1.2.4.1 E3 I/O Module Overview **1-41**
 - 1.2.4.2 E1 I/O Module Overview **1-42**
 - 1.2.4.3 OC-3c I/O Module Overview **1-43**
 - 1.2.4.4 I/O Module Wire-Wrap Pins **1-44**
- 1.2.5 PEM **1-45**
- 1.2.6 Fan Tray **1-47**
- 1.2.7 Air Filters **1-48**
- 1.2.8 ESD Jack **1-48**
- 1.2.9 Third-Party POTS Splitter **1-49**
- 1.3 Management Software **1-49**
 - 1.3.1 Management Software-Generated Alarms **1-49**

CHAPTER 2

Preparing for Installation 2-1

- 2.1 Safety Requirements **2-1**
 - 2.1.1 Safety Guidelines **2-1**
 - 2.1.2 Warning Definition **2-2**
 - 2.1.3 Preventing Electrostatic Discharge Damage **2-9**
 - 2.1.4 General Maintenance Guidelines **2-10**
 - 2.1.4.1 Hot Swapping Cards **2-10**
 - 2.1.4.2 Hot Swapping I/O Modules **2-10**
 - 2.1.4.3 Installation and Replacement Suggestions **2-11**
- 2.2 Site Requirements **2-11**
 - 2.2.1 Environmental Requirements **2-11**
 - 2.2.1.1 Temperature, Altitude, and Humidity **2-12**
 - 2.2.1.2 Ventilation **2-12**
 - 2.2.1.3 Space **2-13**
 - 2.2.2 Power Requirements **2-14**
 - 2.2.3 Rack-Mounting Requirements **2-15**
- 2.3 Required Tools and Equipment **2-16**

- 2.4 Unpacking the Cisco 6260 System **2-18**
- 2.5 Verifying Contents **2-18**
- 2.6 Inspecting for Damage **2-18**

CHAPTER 3**Installing a Cisco 6260 with a POTS Splitter Configuration 3-1**

- 3.1 Installation Checklist **3-2**
- 3.2 Installation Procedures **3-3**
 - 3.2.1 Measure Rack Space **3-3**
 - 3.2.2 Install the Third-Party POTS Splitter **3-3**
 - 3.2.3 Attach Ear Brackets to the Cisco 6260 **3-4**
 - 3.2.4 Install the Cisco 6260 Chassis **3-5**
 - 3.2.5 Install Blank Faceplates **3-6**
 - 3.2.6 Ground the Cisco 6260 **3-7**
 - 3.2.7 Ground the Third-Party POTS Splitter **3-8**
 - 3.2.8 Connect the Cisco 6260 to the Third-Party POTS Splitter **3-9**
 - 3.2.9 Connect the Third-Party POTS Splitter to the MDF or to the Cross Connect **3-9**
 - 3.2.10 Attach Cisco 6260 Power Connections **3-9**
 - 3.2.11 Connect the Alarm and BITS Clock Contacts **3-13**
 - 3.2.12 Apply Power **3-14**
 - 3.2.13 Verify Fan Tray Operation **3-15**
 - 3.2.14 Connect the Cisco 6260 System to the Network **3-15**
 - 3.2.14.1 E3 Network Connection **3-15**
 - 3.2.14.2 E1 Network Connection **3-16**
 - 3.2.14.3 OC-3c Network Connection **3-17**
 - 3.2.15 Install a Subtended Network Configuration **3-18**
 - 3.2.15.1 Connect the E3 Subtending Network Configuration **3-18**
 - 3.2.15.2 Connect the E1 Subtending Network Configuration **3-19**
 - 3.2.15.3 Connect the OC-3c Subtending Network Configuration **3-20**
 - 3.2.16 Connect the Ethernet to the Management Network **3-20**
 - 3.2.17 Connect a Console Terminal **3-21**
 - 3.2.18 Connect the Auxiliary Port **3-21**
 - 3.2.19 Complete Initial Configuration **3-22**
 - 3.2.19.1 Before You Begin **3-22**
 - 3.2.19.2 Using the System Configuration Dialog **3-22**

CHAPTER 4**Installing a Cisco 6260 Without a POTS Splitter Configuration 4-1**

- 4.1 Installation Checklist **4-2**
- 4.2 Installation Procedures **4-2**
 - 4.2.1 Measure Rack Space **4-2**

- 4.2.2 Attach Ear Brackets to the Cisco 6260 4-4
- 4.2.3 Install the Cisco 6260 Chassis 4-5
- 4.2.4 Install Blank Faceplates 4-6
- 4.2.5 Ground the Cisco 6260 4-7
- 4.2.6 Connect the Cisco 6260 to the MDF 4-8
- 4.2.7 Attach Cisco 6260 Power Connections 4-9
- 4.2.8 Connect the Alarm and BITS Clock Contacts 4-12
- 4.2.9 Apply Power 4-13
- 4.2.10 Verify Fan Tray Operation 4-14
- 4.2.11 Connect the Cisco 6260 System to the Network 4-14
 - 4.2.11.1 E3 Network Connection 4-14
 - 4.2.11.2 E1 Network Connection 4-15
 - 4.2.11.3 OC-3c Network Connection 4-16
- 4.2.12 Install a Subtended Network Configuration 4-17
 - 4.2.12.1 Connect the E3 Subtending Network Configuration 4-17
 - 4.2.12.2 Connect the E1 Subtending Network Configuration 4-18
 - 4.2.12.3 Connect the OC-3c Subtending Network Configuration 4-19
- 4.2.13 Connect the Ethernet to the Management Network 4-19
- 4.2.14 Connect a Console Terminal 4-20
- 4.2.15 Connect the Auxiliary Port 4-20
- 4.2.16 Complete Initial Configuration 4-21
 - 4.2.16.1 Before You Begin 4-21
 - 4.2.16.2 Using the System Configuration Dialog 4-21

CHAPTER 5

Troubleshooting 5-1

- 5.1 Hot-Swappable FRUs 5-1
- 5.2 Basic Checks 5-2
- 5.3 Contacting the Cisco TAC for Help 5-2
- 5.4 System-Wide Problems 5-3
- 5.5 FRU-Specific Problems 5-8
 - 5.5.1 NI-2 Card Problems 5-8
 - 5.5.2 NI-2 Card Redundancy Problems 5-9
 - 5.5.3 Line Card Problems 5-10
 - 5.5.4 I/O Module Problems 5-14
 - 5.5.5 Fan Tray Problems 5-15
 - 5.5.6 PEM Problems 5-16
- 5.6 Alarms 5-17

CHAPTER 6**Upgrading and Maintaining the Cisco 6260 System 6-1**

- 6.1 Backing Up Software **6-1**
- 6.2 Fan Tray Maintenance **6-2**
 - 6.2.1 Replacing or Cleaning the Air Filter **6-2**
 - 6.2.1.1 Required Tools and Equipment **6-2**
 - 6.2.1.2 Removing an Air Filter **6-3**
 - 6.2.1.3 Cleaning the Air Filter **6-4**
 - 6.2.1.4 Replacing the Air Filter **6-4**
 - 6.2.2 Removing and Replacing the Fan Tray **6-4**
- 6.3 Installing and Replacing Hardware **6-6**
 - 6.3.1 xTU-C Line Card **6-7**
 - 6.3.1.1 Installing an xTU-C Line Card **6-7**
 - 6.3.1.2 Removing an xTU-C Line Card **6-9**
 - 6.3.2 DS3/2DS3 NI-2 Card **6-9**
 - 6.3.2.1 Installing a DS3/2DS3 NI-2 Card **6-10**
 - 6.3.2.2 Removing a DS3/2DS3 NI-2 Card **6-12**
 - 6.3.3 DS3+T1/E1 IMA NI-2 Card **6-12**
 - 6.3.3.1 Installing a DS3+T1/E1 IMA NI-2 Card **6-13**
 - 6.3.3.2 Removing a DS3+T1/E1 IMA NI-2 Card **6-14**
 - 6.3.4 OC-3c/OC-3c NI-2 Card **6-15**
 - 6.3.4.1 Installing an OC-3c/OC-3c NI-2 Card **6-16**
 - 6.3.4.2 Removing an OC-3c/OC-3c NI-2 Card **6-17**
 - 6.3.5 I/O Module **6-17**
 - 6.3.5.1 Installing an I/O Module **6-18**
 - 6.3.5.2 Removing an I/O Module **6-19**
 - 6.3.6 PEM **6-20**
 - 6.3.6.1 Installing the PEM **6-20**
 - 6.3.6.2 Removing the PEM **6-22**

APPENDIX A**Technical Specifications A-1**

- A.1 Hardware Specifications **A-1**
 - A.1.1 Cisco 6260 Chassis **A-2**
 - A.1.2 Quad-Port DMT ATU-C Line Card **A-3**
 - A.1.3 Quad-Port DMT over ISDN Line Card **A-4**
 - A.1.4 Quad-Port Flexi ATU-C Line Card **A-4**
 - A.1.5 Quad-Port STU-C Line Card **A-5**
 - A.1.6 Octal-Port DMT ATU-C Line Card **A-6**
 - A.1.7 Octal-Port DMT ATU-C Over ISDN Line Card **A-7**
 - A.1.8 Octal-Port G.SHDSL SHTU-C Line Card **A-7**

- A.1.9 DS3/2DS3 NI-2 Card **A-8**
- A.1.10 DS3+T1/E1 IMA NI-2 Card **A-9**
- A.1.11 OC-3c/OC-3c NI-2 Card **A-10**
- A.1.12 I/O Module **A-11**
- A.1.13 PEM **A-11**
- A.1.14 Fan Tray **A-12**
- A.2 Software Specifications **A-12**

APPENDIX B**Port Mapping Specifications B-1**

- B.1 Port Mapping Table **B-1**
- B.2 Standard Telco Color Chart **B-6**

APPENDIX C**Connector and Pinout Specifications C-1**

- C.1 xDSL Connectors **C-1**
- C.2 I/O Module Connectors **C-1**
 - C.2.1 E3 I/O Module BNC Connectors **C-2**
 - C.2.2 E1 I/O Module RJ-48c Connectors **C-2**
- C.3 I/O Module Wire-Wrap Pins **C-3**
- C.4 Console and Auxiliary Ports **C-4**
- C.5 Ethernet Port **C-5**

INDEX



<i>Figure 1-1</i>	Cisco 6260 Chassis Components	1-2
<i>Figure 1-2</i>	Inverse Multiplexing and Recombining of ATM Cells Through IMA Groups	1-5
<i>Figure 1-3</i>	Subtended Network Configuration with DS3/2DS3 NI-2 Cards	1-8
<i>Figure 1-4</i>	Subtended Network Configuration Using DS3+T1/E1 IMA NI-2 Cards	1-9
<i>Figure 1-5</i>	Daisy Chain Topology for OC-3c Interfaces	1-10
<i>Figure 1-6</i>	Cisco 6260 Card Slots	1-12
<i>Figure 1-7</i>	Cisco 6260 Champ Connectors	1-13
<i>Figure 1-8</i>	4xDMT Faceplate	1-14
<i>Figure 1-9</i>	4xDMT over ISDN Faceplate	1-16
<i>Figure 1-10</i>	4xflexi Faceplate	1-18
<i>Figure 1-11</i>	4xSDSL Faceplate	1-20
<i>Figure 1-12</i>	8xDMT Faceplate	1-22
<i>Figure 1-13</i>	8xDMT Over ISDN Faceplate	1-24
<i>Figure 1-14</i>	8xG.SHDSL Faceplate	1-26
<i>Figure 1-15</i>	8xG.SHDSL Deployment in the Cisco 6260 System.	1-29
<i>Figure 1-16</i>	DS3/2DS3 NI-2 Card Faceplate	1-31
<i>Figure 1-17</i>	DS3+T1/E1 IMA NI-2 Card Faceplate	1-34
<i>Figure 1-18</i>	OC-3c/OC-3c NI-2 Card Faceplate	1-37
<i>Figure 1-19</i>	E3 I/O Module	1-42
<i>Figure 1-20</i>	E3 I/O Module	1-43
<i>Figure 1-21</i>	OC-3c I/O Module	1-43
<i>Figure 1-22</i>	I/O Module Wire-Wrap Pins Close-Up	1-44
<i>Figure 1-23</i>	PEM Faceplate	1-46
<i>Figure 1-24</i>	Cisco 6260 Fan Tray	1-47
<i>Figure 1-25</i>	Air Filters	1-48
<i>Figure 2-1</i>	Air Flow Through Intake and Exhaust Vents on the Cisco 6260 Chassis.	2-13
<i>Figure 3-1</i>	Mounting Options for Ear Brackets	3-4
<i>Figure 3-2</i>	Screw the Mounting Aids to the Rack	3-5
<i>Figure 3-3</i>	Mounting Aids Support the Chassis During Installation	3-6
<i>Figure 3-4</i>	System Ground Connection	3-8
<i>Figure 3-5</i>	Strip and Square Off Power and Ground Wires	3-10

<i>Figure 3-6</i>	Positioning the Power and Ground Terminals to Accept Wires	3-11
<i>Figure 3-7</i>	Insert Grounding Wire into Grounding Receptacle	3-12
<i>Figure 3-8</i>	Connecting Power to the Terminal Block	3-13
<i>Figure 3-9</i>	I/O Module Wire-Wrap Pins Close-up	3-14
<i>Figure 3-10</i>	E3 I/O Module BNC Connectors	3-16
<i>Figure 3-11</i>	E1 I/O Module BNC Connectors	3-17
<i>Figure 3-12</i>	E3 I/O Module BNC Connectors	3-18
<i>Figure 3-13</i>	E1 I/O Module RJ-48 Connectors	3-19
<i>Figure 4-1</i>	Mounting Options for Ear Brackets	4-4
<i>Figure 4-2</i>	Screw the Mounting Aids to the Rack	4-5
<i>Figure 4-3</i>	Mounting Aids Support the Chassis During Installation	4-6
<i>Figure 4-4</i>	System Ground Connection	4-8
<i>Figure 4-5</i>	Strip and Square Off Power and Ground Wires	4-10
<i>Figure 4-6</i>	Positioning the Power and Ground Terminals to Accept Wires	4-10
<i>Figure 4-7</i>	Insert Grounding Wire into Grounding Receptacle	4-11
<i>Figure 4-8</i>	Connecting Power to the Terminal Block	4-12
<i>Figure 4-9</i>	I/O Module Wire-Wrap Pins Close-up	4-13
<i>Figure 4-10</i>	E3 I/O Module BNC Connectors	4-15
<i>Figure 4-11</i>	E1 I/O Module BNC Connectors	4-16
<i>Figure 4-12</i>	E3 I/O Module BNC Connectors	4-17
<i>Figure 4-13</i>	E1 I/O Module RJ-48 Connectors	4-18
<i>Figure 6-1</i>	Removing the Bezel and Air Filters	6-3
<i>Figure 6-2</i>	Close-up View of Cisco 6260 Chassis with Fan Trays and Bezel	6-5
<i>Figure 6-3</i>	xTU-C Line Card Installation	6-8
<i>Figure 6-4</i>	Positioning the Locking Tab for the xTU-C Line Card Installation and Removal	6-8
<i>Figure 6-5</i>	NI-2 Card Installation	6-11
<i>Figure 6-6</i>	Positioning the Locking Tab for NI-2 Card Removal and Installation	6-11
<i>Figure 6-7</i>	I/O Interface Module Retaining Screws	6-20
<i>Figure 6-8</i>	PEM Installation	6-21
<i>Figure C-1</i>	xDSL Connector Pin Locations	C-1
<i>Figure C-2</i>	BNC Connectors on the E3 I/O Module	C-2
<i>Figure C-3</i>	RJ-48c Connectors on the E1 I/O Module	C-2
<i>Figure C-4</i>	I/O Module Wire-Wrap Pins Close-Up	C-3
<i>Figure C-5</i>	NI-2 Card Console and Auxiliary Connector	C-4
<i>Figure C-6</i>	NI-2 Card Management Ethernet Connector	C-5



T A B L E S

<i>Table 1</i>	Font Conventions	xiv
<i>Table 2</i>	Command Syntax Conventions	xiv
<i>Table 1-1</i>	IMA Group Interface Names	1-6
<i>Table 1-2</i>	Cisco 6260 Card Slot Assignments	1-11
<i>Table 1-3</i>	4xDMT LED Indicators	1-14
<i>Table 1-4</i>	4xDMT over ISDN LED Indicators	1-16
<i>Table 1-5</i>	4xflexi LED Indicators	1-18
<i>Table 1-6</i>	4xSDSL LED Indicators	1-20
<i>Table 1-7</i>	8xDMT LED Indicators	1-22
<i>Table 1-8</i>	8xDMT over ISDN LED Indicators	1-24
<i>Table 1-9</i>	8xG.SHDSL LED Indicators	1-26
<i>Table 1-10</i>	DS3/2DS3 NI-2 Card LED Group Indicators	1-32
<i>Table 1-11</i>	DS3+T1/E1 IMA NI-2 Card LED Group Indicators	1-35
<i>Table 1-12</i>	OC-3c/OC-3c NI-2 Card LED Group Indicators	1-38
<i>Table 1-13</i>	Pin Assignments for the Cisco 6260 I/O Module	1-45
<i>Table 1-14</i>	PEM LEDs	1-46
<i>Table 2-1</i>	CO Operating Environment Requirements	2-12
<i>Table 2-2</i>	Rack Space Calculation for the Cisco 6260 System Configurations	2-14
<i>Table 2-3</i>	Power Calculation for the Cisco 6260 System	2-14
<i>Table 2-4</i>	Tool and Equipment Requirements Checklist	2-16
<i>Table 3-1</i>	Installation Checklist—Cisco 6260 with a POTS Splitter Configuration	3-2
<i>Table 3-2</i>	Terminal Settings	3-21
<i>Table 4-1</i>	Installation Checklist—Cisco 6260 without a POTS Splitter Configuration	4-2
<i>Table 4-2</i>	Terminal Settings	4-20
<i>Table 5-1</i>	Service Interruptions Caused by Replacing FRUs	5-1
<i>Table 5-2</i>	System-Wide Problems	5-3
<i>Table 5-3</i>	NI-2 Card Problems	5-8
<i>Table 5-4</i>	NI-2 Card Cold Redundancy Problems	5-9
<i>Table 5-5</i>	Line Card Problems	5-10
<i>Table 5-6</i>	I/O Module Problems	5-14
<i>Table 5-7</i>	Fan Tray Problems	5-15

<i>Table 5-8</i>	PEM Problems	5-16
<i>Table 5-9</i>	Chassis Alarm	5-17
<i>Table 5-10</i>	Card Slot Alarms	5-17
<i>Table 5-11</i>	Line Card Alarms	5-17
<i>Table 5-12</i>	IOS Controller Alarms	5-17
<i>Table 5-13</i>	OC-3c/Synchronous Transfer Mode (STM-1) Network Interface Alarms	5-18
<i>Table 5-14</i>	DS3/E3 Network Interface Alarms	5-18
<i>Table 5-15</i>	E1 Network Interface Alarms	5-19
<i>Table 5-16</i>	IMA Link Network Interface Alarms	5-19
<i>Table 5-17</i>	IMA Group Alarms	5-20
<i>Table 5-18</i>	NI-2 Card Redundancy Alarms	5-20
<i>Table 5-19</i>	Fan Tray Alarms	5-21
<i>Table 5-20</i>	Power Alarms	5-21
<i>Table A-1</i>	Cisco 6260 Hardware Specifications	A-2
<i>Table A-2</i>	Quad-Port DMT ATU-C Line Card Specifications	A-3
<i>Table A-3</i>	Quad-Port DMT Over ISDN Line Card Specifications	A-4
<i>Table A-4</i>	Quad-Port Flexi ATU-C Line Card Specifications	A-4
<i>Table A-5</i>	Quad-Port STU-C Line Card Specifications	A-5
<i>Table A-6</i>	Octal-Port DMT ATU-C Line Card Specifications	A-6
<i>Table A-7</i>	Octal-Port DMT ATU-C Over ISDN Line Card Specifications	A-7
<i>Table A-8</i>	Octal-port G.SHDSL SHTU-C Line Card Specifications	A-7
<i>Table A-9</i>	DS3/2DS3 NI-2 Card Specifications	A-8
<i>Table A-10</i>	DS3+T1/E1 IMA NI-2 Card Specifications	A-9
<i>Table A-11</i>	OC-3c/OC-3c NI-2 Card Specifications	A-10
<i>Table A-12</i>	I/O Module Specifications	A-11
<i>Table A-13</i>	PEM Specifications	A-11
<i>Table A-14</i>	Fan Tray Specifications	A-12
<i>Table A-15</i>	Software Specifications	A-12
<i>Table B-1</i>	Port Mapping for Cisco 6260 Subscriber Connectors	B-2
<i>Table B-2</i>	Standard Telco Color Chart	B-6
<i>Table C-1</i>	I/O Module Wire-Wrap Pin Mapping	C-3
<i>Table C-2</i>	Pin Assignments for the NI-2 Card Console and Auxiliary Connectors	C-4
<i>Table C-3</i>	Pin Assignments for the NI-2 Card Management Ethernet Connector	C-5



Preface

This preface explains the audience, purpose, and organization of the *Cisco 6260 Hardware Installation Guide*. It also defines the conventions that are used to present instructions and information.

Audience

The *Cisco 6260 Hardware Installation Guide* is intended for use by central office (CO) technicians and maintenance personnel who are responsible for installing, configuring, and maintaining the Cisco 6260 system. A familiarity with telco products and networking systems is recommended.

Purpose

The *Cisco 6260 Hardware Installation Guide* describes how to set up, install, and troubleshoot the Cisco 6260 system. After completing the installation procedures covered in this guide, refer to the appropriate related documents to provision your Cisco 6260 system. For additional information on related documentation, see the “Related Documentation” section on page xv.

Organization

The *Cisco 6260 Hardware Installation Guide* is organized as follows:

- Chapter 1, “Product Overview,” provides an overview of the Cisco 6260 and describes the system hardware components.
- Chapter 2, “Preparing for Installation,” provides the requirements necessary to prepare for the installation of the Cisco 6260 system.
- Chapter 3, “Installing a Cisco 6260 with a POTS Splitter Configuration,” provides installation procedures for a Cisco 6260 system with a POTS splitter configuration.
- Chapter 4, “Installing a Cisco 6260 Without a POTS Splitter Configuration,” provides installation procedures for a Cisco 6260 system without a POTS splitter configuration.
- Chapter 5, “Troubleshooting,” provides troubleshooting procedures for hardware and software conditions in the Cisco 6260.
- Chapter 6, “Upgrading and Maintaining the Cisco 6260 System,” provides procedures for removing and installing system components, as well as information on maintaining the Cisco 6260 system.

- Appendix A, “Technical Specifications,” provides the technical specifications for the Cisco 6260 system.
- Appendix B, “Port Mapping Specifications,” provides cabling guidelines and port mapping tables for the Cisco 6260 system.
- Appendix C, “Connector and Pinout Specifications,” provides information about connectors and pinouts for the Cisco 6260 system.
- Glossary.
- Index.

Conventions

This publication uses the document conventions listed in this section.

Table 1 *Font Conventions*

Convention	Definition	Sample
Times bold	Text body font used for any argument, command, keyword, or punctuation that is part of a command that the user enters in text and command environments. Also used for names of some GUI elements.	This is similar to the UNIX route command.
<i>Times italic</i>	Text body font used for publication names and for emphasis.	See the <i>Cisco 6200 Series User Guide</i> for further details.
Courier	Font used for screen displays, prompts, and scripts.	Are you ready to continue? [Y]
Courier bold	Font used to indicate what the user enters in examples of command environments.	Login: root Password: < password >

Table 2 *Command Syntax Conventions*

Convention	Definition	Sample
Vertical bar ()	Separates alternative, mutually exclusive elements.	offset-list {in out} offset
Square brackets ([])	Indicate optional elements.	[no] offset-list {in out} offset
Braces ({ })	Indicate a required choice.	offset-list {in out} offset
Braces within square brackets ([{ }])	Indicate a required choice within an optional element.	[{letter\number}Enter]

Table 2 *Command Syntax Conventions (continued)*

Convention	Definition	Sample
Boldface	Indicates commands and keywords that are entered literally as shown	[no] offset-list {in out} offset
<i>Italics</i>	Indicate arguments for which you supply values. Note In contexts that do not allow italics, arguments are enclosed in angle brackets (< >).	<i>offset-list {in out} offset</i>

**Note**

Means *reader take note*. Notes contain helpful suggestions or references to material not covered in the manual.

**Timesaver**

Means *the described action saves time*. You can save time by performing the action described in the paragraph.

**Tip**

Means *the following information will help you solve a problem*. The tip information might not be troubleshooting or even an action, but could be useful information, similar to a Timesaver.

**Caution**

Means *reader be careful*. In this situation, you might do something that could result in equipment damage or loss of data.

**Warning**

Means *danger*. You are in a situation that could cause bodily injury. Before you work on any equipment, you must be aware of the hazards involved with electrical circuitry and be familiar with standard practices for preventing accidents. To see translated versions of the warning, refer to the *Regulatory Compliance and Safety* document that accompanied the device.

Related Documentation

A complete list of all DSL product-related documentation is available on the World Wide Web at http://www.cisco.com/univercd/cc/td/doc/product/dsl_prod/index.htm.

Obtaining Documentation

The following sections provide sources for obtaining documentation from Cisco Systems.

World Wide Web

You can access the most current Cisco documentation on the World Wide Web at the following sites:

- <http://www.cisco.com>
- <http://www-china.cisco.com>
- <http://www-europe.cisco.com>

Documentation CD-ROM

Cisco documentation and additional literature are available in a CD-ROM package, which ships with your product. The Documentation CD-ROM is updated monthly and may be more current than printed documentation. The CD-ROM package is available as a single unit or through an annual subscription.

Ordering Documentation

Some Cisco documentation is available in the following ways:

- Registered Cisco Direct Customers can order Cisco Product documentation from the Networking Products MarketPlace:
http://www.cisco.com/cgi-bin/order/order_root.pl
- Registered Cisco.com users can order the Documentation CD-ROM through the online Subscription Store:
<http://www.cisco.com/go/subscription>
- Nonregistered CCO users can order documentation through a local account representative by calling Cisco corporate headquarters (California, USA) at 408 526-7208 or, in North America, by calling 800 553-NETS(6387).

Documentation Feedback

If you are reading Cisco product documentation on the World Wide Web, you can submit technical comments electronically. Click the **Feedback** link at the top of the Cisco documentation page. After you complete the form, click **Submit** to send it to Cisco.

You can e-mail your comments to bug-doc@cisco.com.

To submit your comments by mail, write to the following address:

Cisco Systems, Inc.
Document Resource Connection
170 West Tasman Drive
San Jose, CA 95134-9883

We appreciate your comments.

Obtaining Technical Assistance

Cisco provides Cisco.com as a starting point for all technical assistance. Customers and partners can obtain documentation, troubleshooting tips, and sample configurations from online tools. For Cisco.com registered users, additional troubleshooting tools are available from the TAC website.

Cisco.com

Cisco.com is the foundation of a suite of interactive, networked services that provides immediate, open access to Cisco information and resources at anytime, from anywhere in the world. This highly integrated Internet application is a powerful, easy-to-use tool for doing business with Cisco.

Cisco.com provides a broad range of features and services to help customers and partners streamline business processes and improve productivity. Through Cisco.com, you can find information about Cisco and our networking solutions, services, and programs. In addition, you can resolve technical issues with online technical support, download and test software packages, and order Cisco learning materials and merchandise. Valuable online skill assessment, training, and certification programs are also available.

Customers and partners can self-register on Cisco.com to obtain additional personalized information and services. Registered users can order products, check on the status of an order, access technical support, and view benefits specific to their relationships with Cisco.

To access Cisco.com, go to the following website:

<http://www.cisco.com>

Technical Assistance Center

The Cisco TAC website is available to all customers who need technical assistance with a Cisco product or technology that is under warranty or covered by a maintenance contract.

Contacting TAC by Using the Cisco TAC Website

If you have a priority level 3 (P3) or priority level 4 (P4) problem, contact TAC by going to the TAC website:

<http://www.cisco.com/tac>

P3 and P4 level problems are defined as follows:

- P3—Your network performance is degraded. Network functionality is noticeably impaired, but most business operations continue.
- P4—You need information or assistance on Cisco product capabilities, product installation, or basic product configuration.

In each of the above cases, use the Cisco TAC website to quickly find answers to your questions.

To register for Cisco.com, go to the following website:

<http://www.cisco.com/register/>

If you cannot resolve your technical issue by using the TAC online resources, Cisco.com registered users can open a case online by using the TAC Case Open tool at the following website:

<http://www.cisco.com/tac/caseopen>

Contacting TAC by Telephone

If you have a priority level 1 (P1) or priority level 2 (P2) problem, contact TAC by telephone and immediately open a case. To obtain a directory of toll-free numbers for your country, go to the following website:

<http://www.cisco.com/warp/public/687/Directory/DirTAC.shtml>

P1 and P2 level problems are defined as follows:

- P1—Your production network is down, causing a critical impact to business operations if service is not restored quickly. No workaround is available.
- P2—Your production network is severely degraded, affecting significant aspects of your business operations. No workaround is available.



Product Overview

This chapter provides an overview of the Cisco 6260 Digital Subscriber Line (DSL) Access Multiplexer (DSLAM) and its related components, collectively known as the Cisco 6260 system. This chapter contains the following sections:

- Introduction to the Cisco 6260 System, page 1-1
- Cisco 6260 System Overview, page 1-10
- Management Software, page 1-49

1.1 Introduction to the Cisco 6260 System

The Cisco 6260 system is part of the Cisco DSL product family that provides end-to-end service by carrying voice or data traffic, or both, between a subscriber's home or office, a telephone central office (CO), and various networks beyond. The Cisco 6260 system sends and receives subscriber data (often Internet service) over existing copper telephone lines, concentrating all traffic onto a single high-speed trunk for transport to the Internet or a corporate intranet. Before traveling over telephone lines to the DSLAM at the CO, data is modulated by xDSL customer premises equipment (CPE) devices, which are connected to PCs or routers at the subscriber site.

The Cisco 6260 system may include the following components:

- Cisco 6260 chassis—A carrier class DSLAM.
 - xDSL Transmission Unit—central office (xTU-C) line cards and second generation network interface (NI-2) card(s)
 - Input/output module
 - Power entry modules (PEMs)
 - Fan trays

Figure 1-1 shows the location of the Cisco 6260 chassis components.

Figure 1-1 Cisco 6260 Chassis Components

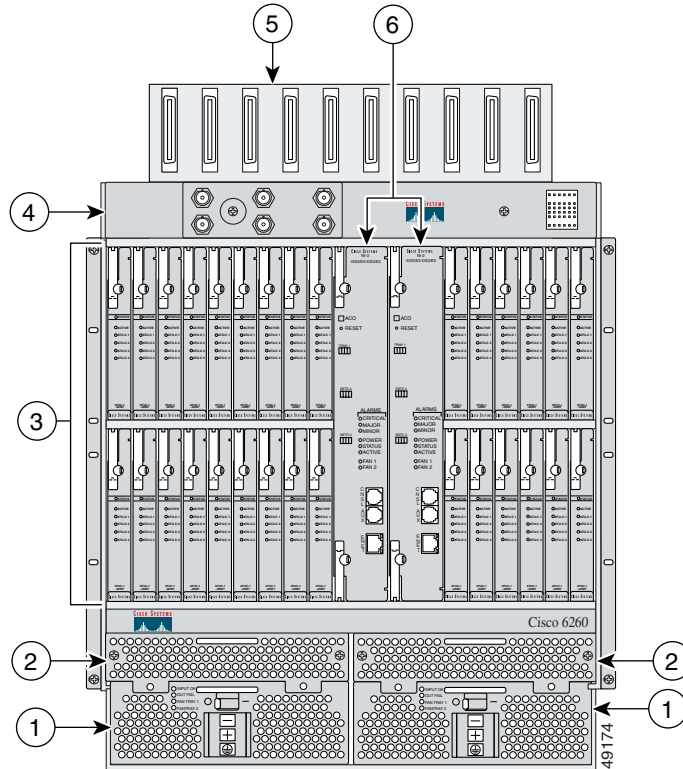

1	PEMs	4	I/O module
2	Fan trays	5	Subscriber champ connectors
3	xTU-C line cards (slots 1 to 9, 12 to 17, 18 to 26, and 27 to 32)	6	NI-2 card(s)

- POTS splitters (optional). The POTS splitter is a passive device that supports simultaneous voice (basic telephone service) and data services.



Note POTS splitters are available from Cisco Ecosystem partners. Please verify the compatibility with your Cisco representative.

For POTS splitter information, refer to the vendor documentation.

- Management software—Provisions and manages the Cisco 6260 system.
 - Cisco IOS—A command-line interface (CLI) that is available for network element provisioning.
 - Cisco DSL Manager (CDM)—An element management system designed to configure and manage the 6xxx series of Cisco IOS software-based DSLAMs through a graphical-user interface (GUI). CDM provides the following areas of network management: fault, configuration, performance, and security. CDM runs within the Cisco Element Manager Framework (EMF); both are installed on Sun workstations.

Cisco EMF is based on an object model in which network elements or modules represent the managed entity. Each object is defined by a class and specific attributes. An object can represent a network element or a more abstract entity such as a link relationship, a network, or a container such as a site, shelf, or region.

**Note**

See the “Hardware Specifications” section on page A-1 for minimum software and network management release requirements per Cisco 6260 chassis component.

1.1.1 Features

The Cisco 6260 system includes the following features:

- Supports ADSL, SDSL, and SHDSL.
- ANSI T1.413 Discrete Multitone (DMT), G.DMT, G.lite, and single-pair, high-speed DSL (G.SHDSL) modem support.
- E3, E1, and OC-3c network transmission connections.
- Small footprint that terminates up to 240 ADSL, 120 SDSL, or 240 G.SHDSL subscriber connections and multiplexes them onto a network trunk.
- European Telecommunication Standards Institute (ETSI) compliant, 19-inch (48.26 cm) chassis.
- Completely front-accessible chassis for cabling and maintenance, eliminating the need for access to the back of the unit.
- Chassis has 30 line card slots, redundant power entry modules (PEMs), and two-speed, software-controlled cooling fans.
- Manageable through IOS or CDM.
- Supports subtending of as many as twelve Cisco 6260 chassis for a maximum of 3120 subscribers.
- Building integrated timing supply (BITS) clock input.
- Facility alarm input.
- Supports the entire range of virtual channel identifier (VCI)/virtual path identifier (VPI) connections, and connections are not limited by memory.
- ATM Forum User-Network Interface (UNI) Version 3.1 compliant.
- Nonblocking ATM switching architecture.
- Allows up to four ATM classes of service simultaneously.

1.1.2 Configurations

This guide provides information about the following configurations:

- Cisco 6260 system with a POTS splitter
- Cisco 6260 system without a POTS splitter
- Inverse multiplexing over ATM (IMA)
- Subtended network

1.1.2.1 Cisco 6260 System with a POTS Splitter Configuration

The Cisco 6260 system with a POTS splitter configuration supports up to 240 data subscribers. To increase subscribership, you can add chassis to your system.

This configuration can include the following hardware components:

- Cisco 6260 chassis
 - Quad-port DMT ATU-C line cards (4xDMTs)
 - Quad-port DMT ATU-C over ISDN line cards (4xDMTs over ISDN)
 - Quad-port flexi ATU-C line cards (4xflexis)
 - Octal-port DMT ATU-C line cards (8xDMTs)
 - Octal-port DMT ATU-C over ISDN line cards (8xDMTs over ISDN)
 - DS3/2DS3, DS3+T1/E1 IMA, or OC-3c/OC-3c NI-2 card
 - E3, E1, or OC-3c I/O module
 - PEM(s)
 - Fan Trays
- Third-party POTS splitter

1.1.2.2 Cisco 6260 System Without a POTS Splitter Configuration

The Cisco 6260 system without a POTS splitter configuration supports up to 240 data subscribers. To increase subscribership, you can add chassis to your system.

This configuration can include the following hardware components:

- Cisco 6260 chassis
 - Quad-port DMT ATU-C line cards (4xDMTs)
 - Quad-port DMT ATU-C over ISDN line cards (4xDMTs over ISDN)
 - Quad-port flexi ATU-C line cards (4xflexis)
 - Quad-port STU-C line cards (4xSDSLs)
 - Octal-port DMT ATU-C line cards (8xDMTs)
 - Octal-Port G.SHDSL SHTU-C line cards (8xG.SHDSL)
 - DS3/2DS3, DS3+T1/E1 IMA, or OC-3c/OC-3c NI-2 card
 - E3, E1, or OC-3c I/O module
 - PEM(s)
 - Fan Trays

1.1.2.3 IMA Configuration

The DS3+T1/E1 IMA NI-2 card uses inverse multiplexing over ATM (IMA) technology to aggregate multiple low-speed links into one larger virtual network trunk or IMA group. An inverse multiplexer appears to your ATM switch router as one logical pipe. IMA provides you with modular bandwidth to access the ATM network between T1/E1 and DS3/E3 rates. The Cisco 6260 system allows you to combine up to eight E1 lines to form an IMA group.

IMA breaks up the ATM cell stream, distributes the cells over the multiple physical links of an IMA group, and recombines the cells into a single stream at the other end of the connection. The ATM cells are distributed in a round-robin fashion over the physical links of the IMA group, recombined at the receiving IMA group, and passed in their original form to the ATM layer (see Figure 1-2). Using the multiple links of an IMA group increases the logical link bandwidth to approximately the sum of the individual link rates. The physical links should be nominally the same length to avoid excessive intragroup delay. We recommend that all of the links in an IMA group be bundled together between the source and the destination.

Figure 1-2 Inverse Multiplexing and Recombining of ATM Cells Through IMA Groups

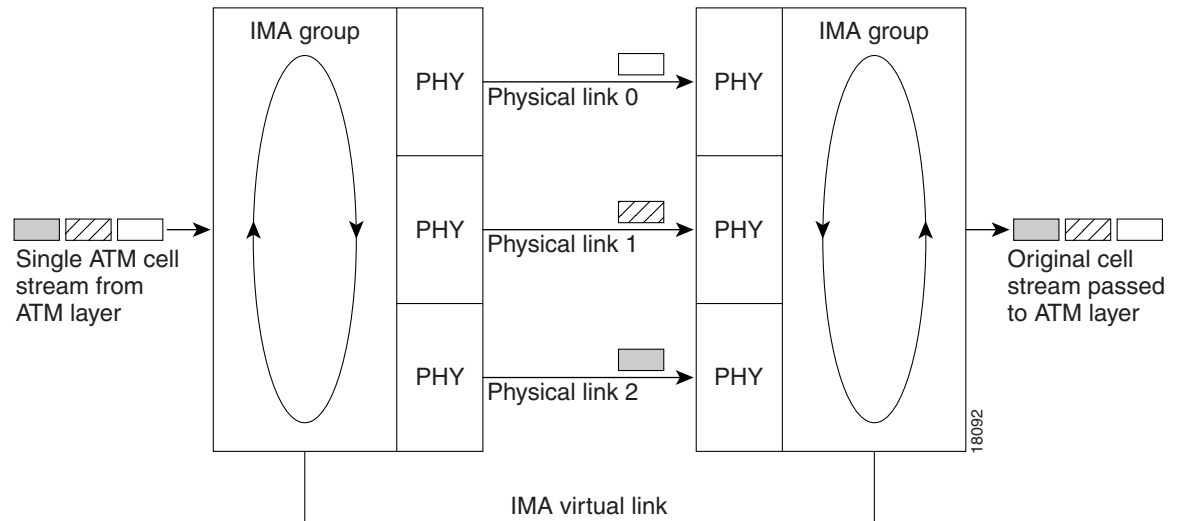

E1 I/O modules have eight ports. You can use the eight ports on the E1 I/O modules as independent ATM links or in the IMA mode. The following bullets are examples of possible IMA groups, independent ATM links, and mixed modes. In examples of IMA groups, two links are assumed per group.

- Four IMA groups with any combination of eight links
- Three IMA groups and up to two independent ATM links
- Two IMA groups and up to four independent ATM links
- One IMA group and up to six independent ATM links
- No IMA group and up to eight independent ATM links

The E1 (1.544 Mbps) IMA port adapters provide network trunk or subtend connectivity and are used for intercampus or wide-area links. The E1 IMA port adapters support unshielded twisted-pair (UTP) connectors. The order of assignment of links to an IMA group is not restricted.

The IMA group interfaces use a naming convention different from those used by the other interfaces in the system. IMA group interfaces are named with the convention `atm<slot>/ima<group>`, where `<slot>` is the slot number for the DS3+T1/E1 IMA NI-2 card and `<group>` is the IMA group number from 0 to 3. Table 1-1 lists the interface naming conventions.

Table 1-1 IMA Group Interface Names

Interface	Name
DS3 link	atm0/1
T1/E1 link 0	atm0/2
T1/E1 link 1	atm0/3
T1/E1 link 2	atm0/4
T1/E1 link 3	atm0/5
T1/E1 link 4	atm0/6
T1/E1 link 5	atm0/7
T1/E1 link 6	atm0/8
T1/E1 link 7	atm0/9
IMA group 0	atm0/ima0
IMA group 1	atm0/ima1
IMA group 2	atm0/ima2
IMA group 3	atm0/ima3

1.1.2.4 Subtended Network Configuration

The term *subtending* refers to the host chassis, and *subtended* refers to the downstream chassis in a subtended network.

Note

For information on enabling redundancy in subtended network configurations, see the “Redundancy in Subtended Configurations” section on page 1-41.

A subtended network configuration

- Services and aggregates the data from one or more Cisco 6260 chassis into a subtending host chassis to take advantage of the data network interface on the subtending host chassis.
- Reduces the number of ATM edge-switch ports required to terminate the chassis.
- Supports a Cisco 6260 system with a POTS splitter and a Cisco 6260 system without a POTS splitter configuration.

A subtended network configuration supports the following features:

- Four arbitration priorities, one for each quality of service (QoS) level. The supported QoS service levels are
 - Constant bit rate (CBR) for rate-limited services that require guaranteed bandwidth and bounded delay
 - Variable bit rate real time (VBR-rt) for delay-sensitive voice and video services
 - Variable bit rate nonreal time (VBR-nrt) for high-priority data services
 - Unspecified bit rate (UBR) for low-priority data services
- Explicit forward congestion indication (EFCI) marking for available bit rate (ABR) service support.
- Guaranteed frame rate (GFR).

- Tree or daisy chain topology configurations for E3 subtended Cisco 6260 chassis.
- Star topology configurations for E1 or IMA group subtended Cisco 6260 chassis.
- Daisy chain configurations for OC-3c subtended Cisco 6260 chassis.
- Fair access to the trunk port for each subtended chassis.
- A network trunk port that operates as fast as any subtended link.

The NI-2 card provides one of following types of subtended network connections:

- An E3 ATM interface
- A high-speed OC-3c optical ATM interface that supports single-mode fiber (SMF) intermediate range
- A high-speed OC-3c optical ATM interface that supports multimode fiber (MMF) short range
- Up to eight E1 interfaces when you are using the DS3+T1/E1 IMA NI-2 card in conjunction with the E1 I/O module.
- Up to four IMA interfaces when you are using the DS3+T1/E1 IMA NI-2 card in conjunction with the E1 I/O module.

The following sections detail the different types of subtending network connections.

1.1.2.4.1 Subtended Network Configuration with DS3/2DS3 NI-2 Cards

In a subtended network configuration using DS3/2DS3 NI-2 cards, you can subtend a Cisco 6260 chassis to four tiers, with up to 12 chassis, all connecting through one subtending host chassis to the ATM backbone.

When the DS3/2DS3 NI-2 card is installed in the Cisco 6260 chassis, it adopts E3 functionality.

Figure 1-3 shows E3-configured Cisco 6260 systems subtended in a combined subtending tree topology with daisy chain. The subtending host chassis at the top of the subtending tree connects directly to the ATM switch. The middle two Cisco 6260 chassis in the lowest level are daisy chained. You make network interface connections at the I/O module that is installed on the front of the Cisco 6260 chassis.

Figure 1-3 Subtended Network Configuration with DS3/2DS3 NI-2 Cards

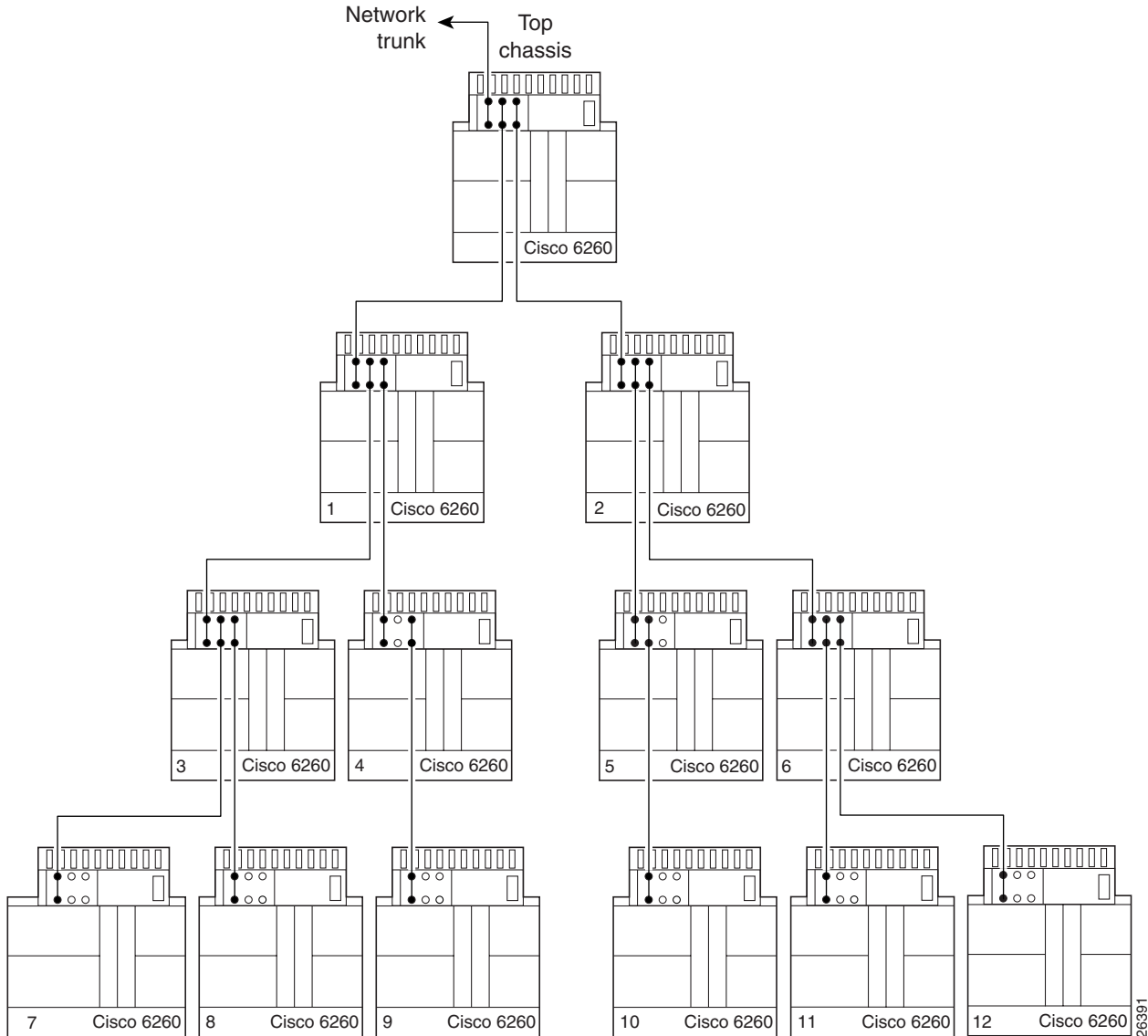

For each chassis in a subtended network configuration to have fair access to the shared network trunk, the chassis must have a unique ID number. The subtending host chassis places this ID number in the GFC field of the ATM header of each cell; this ID number is then used to forward cells up the tree to the network trunk.

**Note**

You can subtend Cisco 6260 chassis with DS3/2DS3 NI-2 cards in a continuous daisy chain. However, a daisy-chained subtending scheme is not optimal for data throughput for Cisco 6260 chassis that use DS3/2DS3 NI-2 cards.

Cisco IOS software does not manage the primary Cisco 6260 chassis and all subtended Cisco 6260 chassis as a single large Cisco 6260 system. Each Cisco 6260 chassis supports an independent Cisco IOS processor and MIBs.

1.1.2.4.2 Subtended Network Configuration with DS3+T1/E1 IMA NI-2 Cards

In a subtended network configuration using DS3+T1/E1 IMA NI-2 cards, you can subtend Cisco 6260 systems in a star topology. The eight E1 links can be used as network trunk or subtend interfaces or can be combined into trunk or subtend IMA groups in the following two ways:

- E1 IMA group or E1 User-Network Interface (UNI) as the network trunk with seven subtended node chassis



Note If you are using an E1 trunk to the network, the trunk connection originates at one of the RJ-48 receptacle connectors on the E1 I/O module. Therefore, you can have only seven subtended node chassis.

- Up to seven individual E1 interfaces or up to four IMA groups, or a combination of the two

Figure 1-4 shows an example of a subtended network with a star topology. The subtending host chassis in the middle of the star topology connects directly to the ATM switch.

Figure 1-4 Subtended Network Configuration Using DS3+T1/E1 IMA NI-2 Cards

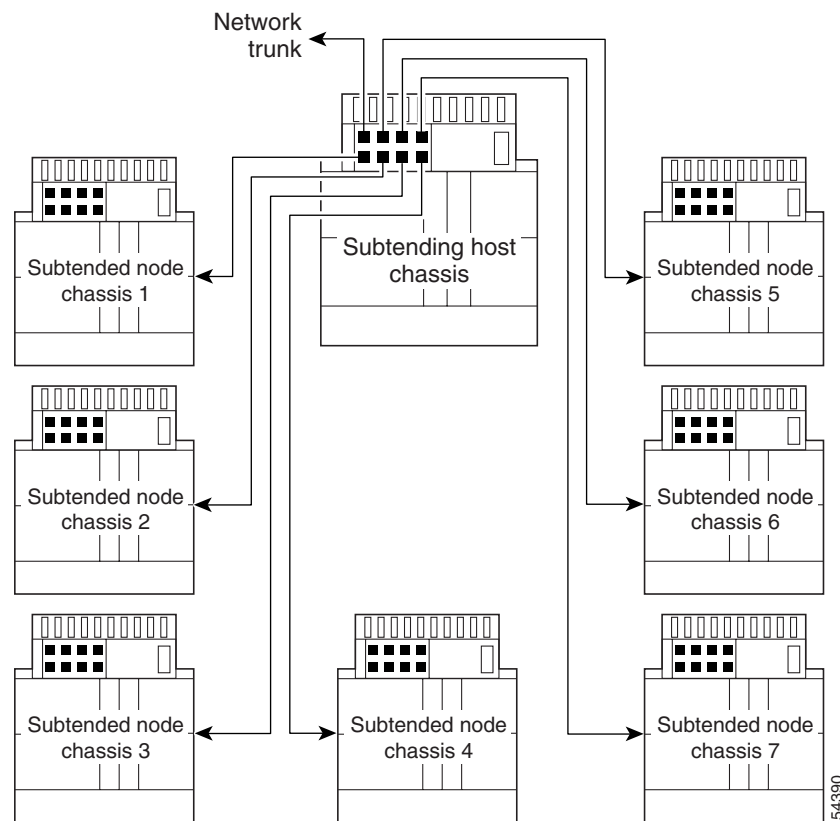

Note Consult with your network architect or Cisco customer service representative for examples of other subtending topology configurations.

1.1.2.4.3 Subtended Network Configuration with OC-3c/OC-3c NI-2 Cards

In a subtended network configuration using OC-3c/OC-3c NI-2 cards (SMF or MMF), you can subtend up to 12 OC-3c configured chassis in a daisy chain, all connecting through one subtending host chassis to the ATM backbone (see Figure 1-5).

Note

The Cisco 6260 chassis can also serve as the subtending host chassis to, or as a subtended node chassis from, the Cisco 6100, Cisco 6130, Cisco 6015, or Cisco 6160 chassis.

Figure 1-5 *Daisy Chain Topology for OC-3c Interfaces*

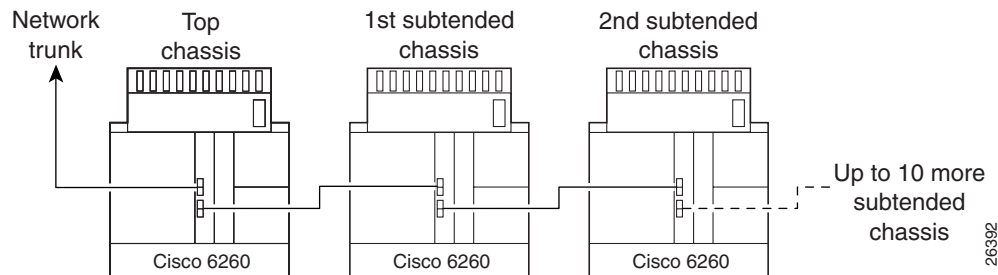

1.2 Cisco 6260 System Overview

The Cisco 6260 system consists of circuitry and connections that reside within a chassis, an enclosure that allows modular insertion and removal of various field-replaceable units (FRUs). The Cisco 6260 system includes

- A card compartment with 32 slots: 30 slots for xTU-C line cards and two slots for NI-2 cards
- A set of connectors that serve subscriber lines with or without POTS splitters
- An I/O module
- Compartments for two PEMs, two fan trays, and air filters.

See Figure 1-1 for the location of the system components in the Cisco 6260 chassis.

Note

For hardware specifications for the Cisco 6260 chassis, see the “Cisco 6260 Chassis” section on page A-2.

1.2.1 Cisco 6260 Card Compartment

The Cisco 6260 chassis contains a 32-slot card compartment holds NI-2 cards and xTU-C line cards. Table 1-2 describes each card slot assignment for the Cisco 6260 chassis.

Table 1-2 Cisco 6260 Card Slot Assignments

Card Slot	Card Assignment
1 to 9	4xDMT, 4xDMT over ISDN, 4xflexi, 4xSDSL ¹ , 8xDMT, 8xDMT over ISDN ² , or 8xG.SHDSL ¹
10	NI-2 card
11	Secondary (redundant) NI-2 card
12 to 32	4xDMT, 4xDMT over ISDN, 4xflexi, 4xSDSL, 8xDMT, 8xDMT over ISDN, or 8xG.SHDSL

1. 4xSDSLs and G.SHDSLs can be used only in a Cisco 6260 system without a POTS splitter configuration.
2. 8xDMT over ISDN can be used only in a Cisco 6260 system with a POTS splitter configuration.

**Note**

You can purchase blank faceplates for empty Cisco 6260 card slots.

Figure 1-6 identifies the Cisco 6260 card slots. Each slot on a chassis is numbered along the top of the chassis. In this guide, the slot numbers are shown on the cards for easy reference and readability. These slots are referred to in subsequent sections of this chapter and elsewhere in this guide.

Figure 1-6 Cisco 6260 Card Slots

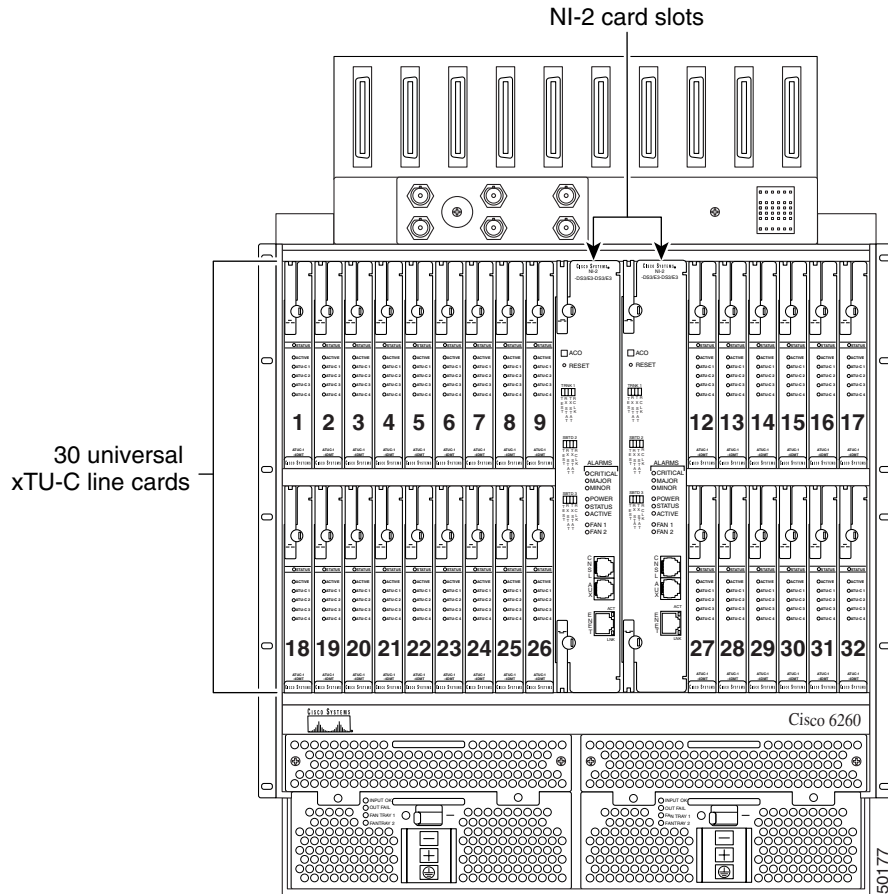
**Note**

Slot 10 is the primary NI-2 card slot, and Slot 11 is the secondary NI-2 card slot. A secondary NI-2 card, when installed in Slot 11, provides cold redundancy.

1.2.2 Cisco 6260 Connectors

Ten female RJ-21 (Champ) subscriber connectors are located at the top of the chassis, facing forward. These 50-pin sockets provide the DSL subscriber connections. Each subscriber connector serves three line card slots. Figure 1-7 depicts the Cisco 6260 subscriber connectors.

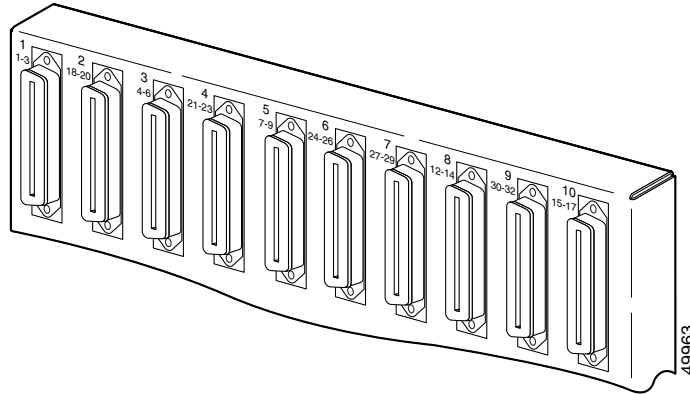
Figure 1-7 Cisco 6260 Champ Connectors

The Cisco 6260 subscriber connectors are numbered 1 to 10. See the “Port Mapping Table” section on page B-1 for information about how subscriber connectors correspond to line card slots and ports.

See Figure 1-1 for the location of the subscriber connectors on the Cisco 6260 chassis.

1.2.3 Cisco 6260 Cards

This section contains the following information:

- Quad-Port DMT ATU-C Line Card Overview, page 1-13
- Quad-Port DMT ATU-C over ISDN Line Card Overview, page 1-15
- Quad-Port Flexi ATU-C Line Card Overview, page 1-17
- Quad-Port STU-C Line Card Overview, page 1-19
- Octal-Port DMT ATU-C Line Card Overview, page 1-21
- Octal-Port DMT ATU-C Over ISDN Line Card Overview, page 1-23
- DS3/2DS3 NI-2 Card Overview, page 1-30
- DS3+T1/E1 IMA NI-2 Card Overview, page 1-32
- OC-3c/OC-3c NI-2 Card Overview, page 1-35

Some line cards can be intermixed within the Cisco 6260 chassis. See the “Line Card Intermixing” section on page 1-27 for intermixing guidelines.

1.2.3.1 Quad-Port DMT ATU-C Line Card Overview

The quad-port DMT ATU-C line card (4xDMT)

- Supports four ADSL modem connections
- Converts ADSL modulation from the line into digital data streams to and from the NI-2 card
- Negotiates the line rate with the CPE when it trains and bases the rate on line quality and distance

If provisioned, the 4xDMT rate adapts to the maximum bit rate negotiable on the line. The maximum bit rate settings are provisioned in the management software.

The chassis can include up to 30 4xDMTs for a total of 120 ADSL modem connections.

**Note**

For hardware specifications for the 4xDMT line card, see the “Quad-Port DMT ATU-C Line Card” section on page A-3.

1.2.3.1.1 Faceplate Features

Figure 1-8 shows a close-up of the 4xDMT faceplate.

Figure 1-8 4xDMT Faceplate

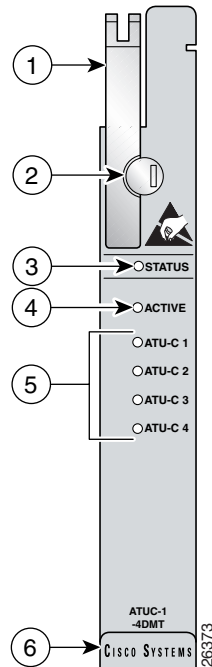

1	Ejector lever	4	ACTIVE LED
2	Locking tab	5	Modem port status LEDs
3	STATUS LED	6	Extraction tab

Table 1-3 describes the 4xDMT LED indicator functions.

Table 1-3 4xDMT LED Indicators

LED	State	Function
STATUS	Green slow blinking	The self-test is in progress.
	Green fast blinking	The image download is in progress.
	Green solid	The status is OK.
	Red	The self-test or line card has failed.
	Off	The ATU-C line card has had a power failure.

Table 1-3 4xDMT LED Indicators (continued)

LED	State	Function
ACTIVE	Green solid	The line card is activated.
	Off	The line card is not in service.
ATUC-1	Green solid	Modem 1 is trained.
	Green blinking	Training is in progress for modem 1.
	Off	Modem 1 is idle.
ATUC-2	Green solid	Modem 2 is trained.
	Green blinking	Training is in progress for modem 2.
	Off	Modem 2 is idle.
ATUC-3	Green solid	Modem 3 is trained.
	Green blinking	Training is in progress for modem 3.
	Off	Modem 3 is idle.
ATUC-4	Green solid	Modem 4 is trained.
	Green blinking	Training is in progress for modem 4.
	Off	Modem 4 is idle.

1.2.3.2 Quad-Port DMT ATU-C over ISDN Line Card Overview

The quad-port DMT ATU-C over ISDN line card (4xDMT over ISDN)

- Supports four ADSL modem connections
- Converts ADSL modulation from the line into digital data streams to and from the NI-2 card
- Negotiates the line rate with the CPE when it trains and bases the rate on line quality and distance
- Contains filters that reject the ISDN spectrum (or signal) during operation
- Separates DMT signals from, or combines them with, ISDN signals, if the CPE includes ISDN telephone service (in a configuration with a connected POTS splitter)

If provisioned, the 4xDMT over ISDN rate adapts to the maximum bit rate negotiable on the line. The maximum bit rate settings are provisioned in the management software.

The chassis can include up to 30 4xDMT over ISDN line cards, for a total of 120 ADSL modem connections.



Note

For hardware specifications for the 4xDMT over ISDN line card, see the “Quad-Port DMT over ISDN Line Card” section on page A-4.

1.2.3.2.1 Faceplate Features

Figure 1-9 shows a close-up of the 4xDMT over ISDN faceplate.

Figure 1-9 4xDMT over ISDN Faceplate

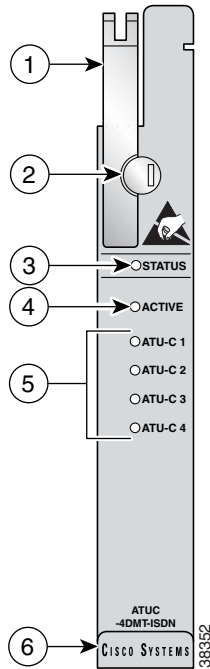

1	Ejector lever	4	ACTIVE LED
2	Locking tab	5	Modem port status LEDs
3	STATUS LED	6	Extraction tab

Table 1-3 describes the 4xDMT over ISDN LED indicator functions.

Table 1-4 4xDMT over ISDN LED Indicators

LED	State	Function
STATUS	Green slow blinking	The self-test is in progress.
	Green fast blinking	The image download is in progress.
	Green solid	The status is OK.
	Red	The self-test or line card has failed.
	Off	The ATU-C line card has had a power failure.
ACTIVE	Green solid	The line card is activated.
	Off	The line card is not in service.

Table 1-4 4xDMT over ISDN LED Indicators (continued)

LED	State	Function
ATUC-1	Green solid	Modem 1 is trained.
	Green blinking	Training is in progress for modem 1.
	Off	Modem 1 is idle.
ATUC-2	Green solid	Modem 2 is trained.
	Green blinking	Training is in progress for modem 2.
	Off	Modem 2 is idle.
ATUC-3	Green solid	Modem 3 is trained.
	Green blinking	Training is in progress for modem 3.
	Off	Modem 3 is idle.
ATUC-4	Green solid	Modem 4 is trained.
	Green blinking	Training is in progress for modem 4.
	Off	Modem 4 is idle.

1.2.3.3 Quad-Port Flexi ATU-C Line Card Overview

The quad-port flexi ATU-C line card (4xflexi)

- Supports DMT line encoding
- Supports four ADSL modem connections
- Converts ADSL modulation from the line into digital data streams to and from the NI-2 card
- Negotiates the line rate with the CPE when it trains and bases the rate on line quality and distance

If provisioned, the 4xflexi rate adapts to the maximum bit rate negotiable on the line. The maximum bit rate settings are provisioned in the management software.

The Cisco 6260 chassis can include up to 30 4xflexi line cards for a total of 120 ADSL modem connections.

The edge connector key, located on the rear of the 4xflexi, connects the 4xflexi to the backplane of the chassis. Two edge connector keys are available for the 4xflexi: one has six notches, and one has seven notches. Only the seven-notched edge connector key can be installed in the Cisco 6260.



Note

For hardware specifications for the 4xflexi, see the “Quad-Port Flexi ATU-C Line Card” section on page A-4.

1.2.3.3.1 Faceplate Features

Figure 1-10 shows a close-up of the 4xflexi faceplate.

Figure 1-10 4xflexi Faceplate

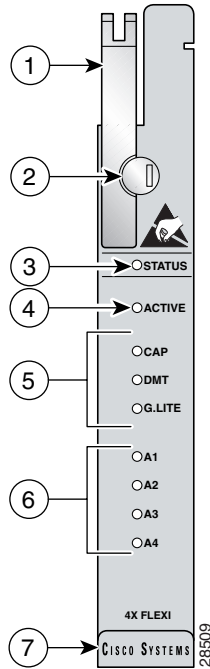

1	Ejector lever	5	Line card mode LEDs
2	Locking tab	6	Modem port status LEDs
3	STATUS LED	7	Extraction tab
4	ACTIVE LED		

Table 1-5 describes the 4xflexi LED indicator functions.

Table 1-5 4xflexi LED Indicators

LED	State	Function
STATUS	Green slow blinking	The self-test is in progress.
	Green fast blinking	The image download is in progress.
	Green solid	The status is OK.
	Red	The self-test or line card has failed.
	Off	The ATU-C line card has had a power failure.
ACTIVE	Green solid	The line card is activated.
	Off	The line card is not in service.

Table 1-5 4xflexi LED Indicators (continued)

LED	State	Function
CAP	Green solid	The line card is in CAP mode. Note CAP mode is not available on the 4xflexi in a Cisco 6260.
	Off	The line card is not in CAP mode.
DMT	Green solid	The line card is in DMT mode.
	Off	The line card is not in DMT mode.
G.LITE	Green solid	The line card is in G.lite mode. Note G.lite mode is not available on the 4xflexi in a Cisco 6260.
	Off	The line card is not in G.lite mode.
A1	Green solid	Modem 1 is trained.
	Green blinking	Training is in progress for modem 1.
	Off	Modem 1 is idle.
A2	Green solid	Modem 2 is trained.
	Green blinking	Training is in progress for modem 2.
	Off	Modem 2 is idle.
A3	Green solid	Modem 3 is trained.
	Green blinking	Training is in progress for modem 3.
	Off	Modem 3 is idle.
A4	Green solid	Modem 4 is trained.
	Green blinking	Training is in progress for modem 4.
	Off	Modem 4 is idle.

1.2.3.4 Quad-Port STU-C Line Card Overview

The quad-port STU-C line card (4xSDSL)

- Supports 2B1Q line encoding
- Is designed for use in a Cisco 6260 system without a POTS splitter configuration
- Supports four SDSL modem connections
- Converts SDSL modulation from the line into digital data streams to and from the NI-2 card

The negotiated bit rate is the lower of the following rates:

- The provisioned bit rate set for the 4xSDSL in the management software
- The assigned bit rate at the CPE

The chassis can include up to 30 4xSDSLs for a total of 120 SDSL modem connections.



Note

For hardware specifications for the 4xSDSL line card, see the “Quad-Port STU-C Line Card” section on page A-5.

The edge connector key, located on the rear of the 4xSDSL, connects the 4xSDSL to the backplane of the chassis. Two edge connector keys are available for the 4xSDSL: one has six notches, and one has seven notches. Only the seven-notched edge connector key can be installed in the Cisco 6260.

1.2.3.4.1 Faceplate Features

Figure 1-11 shows a close-up of the 4xSDSL faceplate.

Figure 1-11 4xSDSL Faceplate

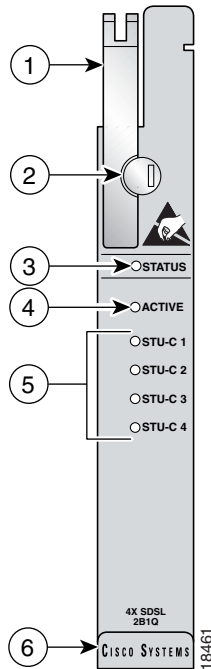

1	Ejector lever	4	ACTIVE LED
2	Locking tab	5	Modem port status LEDs
3	STATUS LED	6	Extraction tab

Table 1-6 describes the 4xSDSL LED indicator functions.

Table 1-6 4xSDSL LED Indicators

LED	State	Function
STATUS	Green slow blinking	The self-test is in progress.
	Green fast blinking	The image download is in progress.
	Green solid	The status is OK.
	Red	The self-test or line card has failed.
	Off	The ATU-C line card has had a power failure.
ACTIVE	Green solid	The line card is activated.
	Off	The line card is not in service.

Table 1-6 4xSDSL LED Indicators (continued)

LED	State	Function
STU-C 1	Green solid	Modem 1 is trained.
	Green blinking	Training is in progress for modem 1.
	Off	Modem 1 is idle.
STU-C 2	Green solid	Modem 2 is trained.
	Green blinking	Training is in progress for modem 2.
	Off	Modem 2 is idle.
STU-C 3	Green solid	Modem 3 is trained.
	Green blinking	Training is in progress for modem 3.
	Off	Modem 3 is idle.
STU-C 4	Green solid	Modem 4 is trained.
	Green blinking	Training is in progress for modem 4.
	Off	Modem 4 is idle.

1.2.3.5 Octal-Port DMT ATU-C Line Card Overview

The octal-port DMT ATU-C line card (8xDMT)

- Supports eight ADSL modem connections
- Converts ADSL modulation from the line into digital data streams to and from the NI-2 card
- Negotiates the line rate with the CPE when it trains and bases the rate on line quality and distance

If provisioned, the 8xDMT rate adapts to the maximum bit rate negotiable on the line. The maximum bit rate settings are provisioned in the management software.

The chassis can include up to 30 8xDMTs for a total of 240 ADSL modem connections.



Note

For hardware specifications for the 8xDMT line card, see the “Octal-Port DMT ATU-C Line Card” section on page A-6.

1.2.3.5.1 Faceplate Features

Figure 1-12 shows a close-up of the 8xDMT faceplate.

Figure 1-12 8xDMT Faceplate

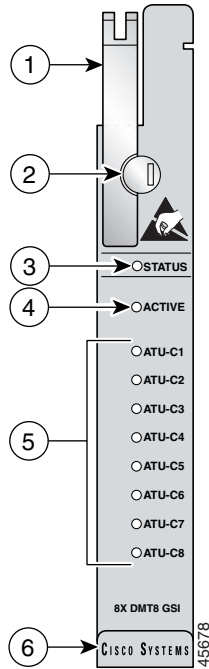

1	Ejector lever	4	ACTIVE LED
2	Locking tab	5	Modem port status LEDs
3	STATUS LED	6	Extraction tab

Table 1-7 describes LEDs on the 8xDMT.

Table 1-7 8xDMT LED Indicators

LED	State	Function
STATUS	Green slow blinking	No errors, but no connection established.
	Green solid	The image download is in progress.
	Red	NI-2 communication established.
	Off	The self-test or line card has failed. The ATU-C line card has had a power failure.
ACTIVE	Green solid	The line card is activated.
	Off	The line card is not in service.
ATU-C 1	Green solid	Modem 1 is trained.
	Green blinking	Training is in progress for modem 1.
	Off	Modem 1 is idle.

Table 1-7 8xDMT LED Indicators (continued)

LED	State	Function
ATU-C 2	Green solid Green blinking Off	Modem 2 is trained. Training is in progress for modem 2. Modem 2 is idle.
ATU-C 3	Green solid Green blinking Off	Modem 3 is trained. Training is in progress for modem 3. Modem 3 is idle.
ATU-C 4	Green solid Green blinking Off	Modem 4 is trained. Training is in progress for modem 4. Modem 4 is idle.
ATU-C 5	Green solid Green blinking Off	Modem 5 is trained. Training is in progress for modem 5. Modem 5 is idle.
ATU-C 6	Green solid Green blinking Off	Modem 6 is trained. Training is in progress for modem 6. Modem 6 is idle.
ATU-C 7	Green solid Green blinking Off	Modem 7 is trained. Training is in progress for modem 7. Modem 7 is idle.
ATU-C 8	Green solid Green blinking Off	Modem 8 is trained. Training is in progress for modem 8. Modem 8 is idle.

1.2.3.6 Octal-Port DMT ATU-C Over ISDN Line Card Overview

The octal-port DMT ATU-C over ISDN line card (8xDMT over ISDN)

- Supports eight ADSL modem connections
- Converts ADSL modulation from the line into digital data streams to and from the NI-2 card
- Negotiates the line rate with the CPE when it trains and bases the rate on line quality and distance



Note

For hardware specifications for the 8xDMT over ISDN line card, see the “Octal-Port DMT ATU-C Over ISDN Line Card” section on page A-7.

1.2.3.6.1 Faceplate Features

Figure 1-13 shows a close-up of the 8xDMT over ISDN faceplate.

Figure 1-13 8xDMT Over ISDN Faceplate

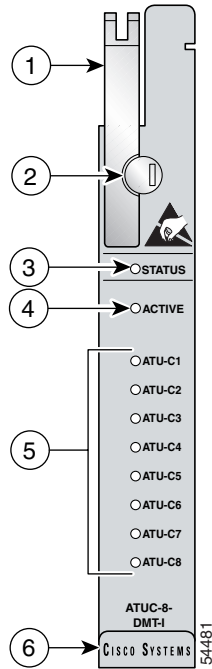

1	Ejector lever	4	ACTIVE LED
2	Locking tab	5	Modem port status LEDs
3	STATUS LED	6	Extraction tab

Table 1-7 describes LEDs on the 8xDMT over ISDN.

Table 1-8 8xDMT over ISDN LED Indicators

LED	State	Function
STATUS	Green slow blinking	No errors, but no connection established.
	Green solid	The image download is in progress.
	Red	NI-2 communication established.
	Off	The self-test or line card has failed. The ATU-C line card has had a power failure.
ACTIVE	Green solid	The line card is activated.
	Off	The line card is not in service.
ATU-C 1	Green solid	Modem 1 is trained.
	Green blinking	Training is in progress for modem 1.
	Off	Modem 1 is idle.

Table 1-8 8xDMT over ISDN LED Indicators (continued)

LED	State	Function
ATU-C 2	Green solid Green blinking Off	Modem 2 is trained. Training is in progress for modem 2. Modem 2 is idle.
ATU-C 3	Green solid Green blinking Off	Modem 3 is trained. Training is in progress for modem 3. Modem 3 is idle.
ATU-C 4	Green solid Green blinking Off	Modem 4 is trained. Training is in progress for modem 4. Modem 4 is idle.
ATU-C 5	Green solid Green blinking Off	Modem 5 is trained. Training is in progress for modem 5. Modem 5 is idle.
ATU-C 6	Green solid Green blinking Off	Modem 6 is trained. Training is in progress for modem 6. Modem 6 is idle.
ATU-C 7	Green solid Green blinking Off	Modem 7 is trained. Training is in progress for modem 7. Modem 7 is idle.
ATU-C 8	Green solid Green blinking Off	Modem 8 is trained. Training is in progress for modem 8. Modem 8 is idle.

1.2.3.7 Octal-Port G.SHDSL SHTU-C Line Card Overview

The octal-port G.SHDSL SHTU-C line card (8xG.SHDSL)

- Supports eight SHDSL modem connections
- Supports trellis coded pulse amplitude modulation (TC-PAM) line encoding
- Converts G.SHDSL modulation from the line into digital data streams to and from the NI-2 card
- Supports fixed and adaptive rate modes
- Has deployment guidelines when used in the Cisco 6260 system; see the “Guidelines for Intermixing 8xG.SHDSLs—Cisco IOS Release 12.2(7)DA and Later” section on page 1-28.



Note

For hardware specifications for the 8xG.SHDSL line card, see the “Octal-Port G.SHDSL SHTU-C Line Card” section on page A-7.

1.2.3.7.1 Faceplate Features

Figure 1-14 shows a close-up of the 8xG.SHDSL faceplate.

Figure 1-14 8xG.SHDSL Faceplate

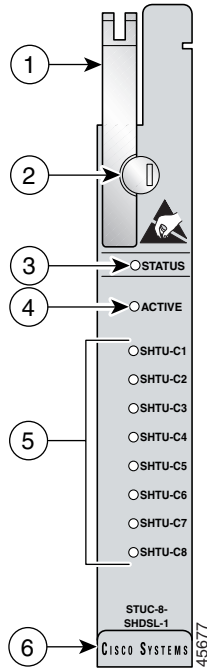

1	Ejector lever	4	ACTIVE LED
2	Locking tab	5	Modem port status LEDs
3	STATUS LED	6	Extraction tab

Table 1-9 describes the 8xG.SHDSL LED indicator functions.

Table 1-9 8xG.SHDSL LED Indicators

LED Label	State	Function
STATUS	Green slow blinking	No errors, but no connection established.
	Green fast blinking	The image download is in progress.
	Green solid	NI-2 communication established.
	Red	The self-test or line card has failed.
	Off	The line card has a power failure.
ACTIVE	Green solid	The line card is activated.
	Off	The line card is not in service.
SHTU-C1	Green solid	Modem 1 is trained.
	Green blinking	Training is in progress for modem 1.
	Off	Modem 1 is idle.

Table 1-9 8xG.SHDSL LED Indicators (continued)

LED Label	State	Function
SHTU-C2	Green solid Green blinking Off	Modem 2 is trained. Training is in progress for modem 2. Modem 2 is idle.
SHTU-C3	Green solid Green blinking Off	Modem 3 is trained. Training is in progress for modem 3. Modem 3 is idle.
SHTU-C4	Green solid Green blinking Off	Modem 4 is trained. Training is in progress for modem 4. Modem 4 is idle.
SHTU-C5	Green solid Green blinking Off	Modem 5 is trained. Training is in progress for modem 5. Modem 5 is idle.
SHTU-C6	Green solid Green blinking Off	Modem 6 is trained. Training is in progress for modem 6. Modem 6 is idle.
SHTU-C7	Green solid Green blinking Off	Modem 7 is trained. Training is in progress for modem 7. Modem 7 is idle.
SHTU-C8	Green solid Green blinking Off	Modem 8 is trained. Training is in progress for modem 8. Modem 8 is idle.

1.2.3.8 Line Card Intermixing

Note

Figure 1-6 shows the Cisco 6260 chassis slot numbers.

The Cisco 6260 chassis supports line card intermixing. This section uses the terms *halves* and *quadrants*. The Cisco 6260 chassis consists of two halves:

- Slots 1 to 9 and slots 18 to 26 (left half of the chassis)
- Slots 12 to 17 and slots 27 to 32 (right half of the chassis)

The Cisco 6260 chassis consists of four quadrants:

- Slots 1 to 9 (top left quadrant)
- Slots 12 to 17 (top right quadrant)
- Slots 18 to 26 (bottom left quadrant)
- Slots 27 to 32 (bottom right quadrant)

The following sections describe the line card intermixing guidelines for the Cisco 6260.

1.2.3.8.1 Guidelines for Intermixing xDSL Line Cards

Mixing line cards of different modulation types in the same quadrant of any Cisco DSLAM is prohibited. Different modulation types are allowed in the same half of a chassis with the exceptions of slots 18 and 34 in the Cisco 6160 beginning with Cisco IOS release 12.2(7)DA. Mixing line cards of the same modulation type (for example, 4xFlexiDMT and 8xDMT line cards) in a quadrant is allowed.

1.2.3.8.2 Guidelines for Intermixing 8xG.SHDSLs—Cisco IOS Release 12.1(7)DA2, 12.2(1b)DA, and 12.2(5)DA

The Cisco 6260 chassis can be fully populated with 8xG.SHDSLs while retaining QoS, as long as the upstream bandwidth is provisioned at a maximum of 5 Mbps for even ports and a maximum of 5 Mbps for odd ports per line card. Once an 8xG.SHDSL is installed in a chassis quadrant, no ADSL line cards can be installed in that same quadrant.

1.2.3.8.3 Guidelines for Intermixing 8xG.SHDSLs—Cisco IOS Release 12.2(7)DA and Later

The Cisco 6260 system supports up to 16 8xG.SHDSLs installed per chassis while retaining QoS. Once an 8xG.SHDSL is installed in a quadrant, no ADSL line cards can be installed in that same quadrant.

Figure 1-15 illustrates the optimal deployment of 8xG.SHDSLs in the Cisco 6260 chassis with quadrant intermixing of ADSL line cards in the Cisco 6260 chassis. For example:

- If 4 8xG.SHDSLs are installed in the left side of the chassis, only 21 ADSL line cards can be installed in the remaining chassis quadrants.



Note No ADSL line cards can be installed in the same quadrant as the 8xG.SHDSLs.

- If 4 8xG.SHDSLs are installed in the right side of the chassis, only 24 ADSL line cards can be installed in the remaining chassis quadrants.



Note No ADSL line cards can be installed in the same quadrant as the 8xG.SHDSLs.



Caution

Random cell loss may occur if the guidelines for 8xG.SHDSL deployment in a system are exceeded.

Figure 1-15 8xG.SHDSL Deployment in the Cisco 6260 System.

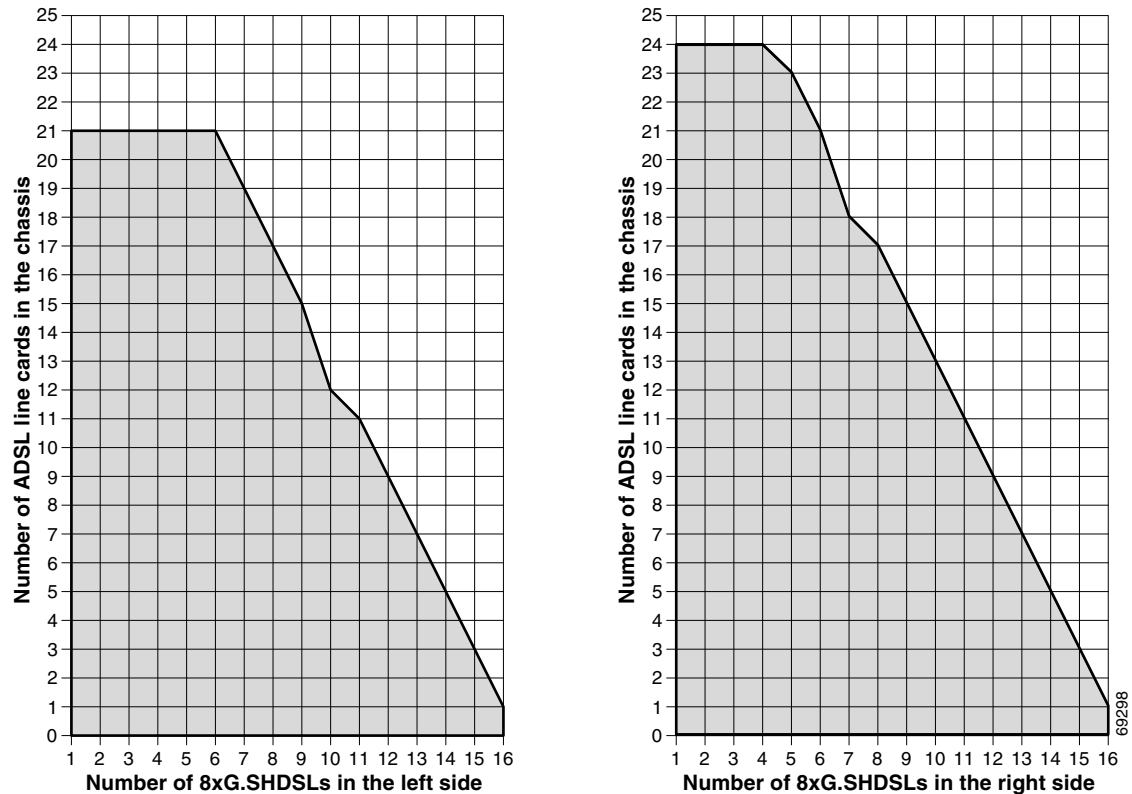

1.2.3.8.4 Guidelines for Intermixing 8xG.SHDSLs—Cisco IOS Release 12.2(12)DA and Later for NI2-155SM-155SM2 or NI2-155MM-155MM2 Only

This section describes intermixing in Cisco IOS Release 12.2(12)DA and later for NI2-155SM-155SM2 or NI2-155MM-155MM2 only. All other NI2s, including NI2-155SM-155SM and NI2-155MM-155MM, follow guidelines as described in the “Guidelines for Intermixing 8xG.SHDSLs—Cisco IOS Release 12.2(7)DA and Later” section on page 1-28.

The Cisco 6015, Cisco 6160, and Cisco 6260 can be fully populated with 8xG.SHDSLs while retaining QoS.

- In the Cisco 6160 and Cisco 6260, once an 8xG.SHDSL is installed in a chassis quadrant, no other type of line card can be installed in that same quadrant.
- In the Cisco 6015, intermixing is limited to chassis halves.



Note

In order to provision 18.5 Mbps per line card in a chassis fully populated with 8xG.SHDSLs, an OC-3c/OC-3c single-mode fiber (SMF) or multi-mode fiber (MMF) NI-2 card (NI2-155SM-155SM2 and NI2-155MM-155MM2) must be installed in the chassis.

1.2.3.9 DS3/2DS3 NI-2 Card Overview

The DS3/2DS3 NI-2 card

- Provides the network E3 network trunk interface through BNC connectors located on the E3 I/O module.



Note The Cisco 6260 system does not support the DS3 interface. When the DS3/2DS3 NI-2 card and the E3 I/O module are installed in the Cisco 6260 chassis, the system adopts E3 functionality.

- Connects to the xTU-C line cards through point-to-point serial data buses on the backplane
- Contains the ATM switch fabric
- Provides CO facility alarm relay contact interfaces and an alarm cut-off (ACO) button
- Provides visual and audible operating status alerts
- Is manageable through Cisco IOS software or through CDM
- Provides Cisco IOS-based ATM QoS
- Controls timing and redundancy



Note The BITS interface is connected through the E3 I/O module located on the front of the Cisco 6260.

- Supports the aggregation of up to 12 subtended node chassis that are configured for E3 operation in a tree topology.
- Provides two E3 subtend interfaces through BNC connectors located on the I/O module.



Note For hardware specifications for the DS3/2DS3 NI-2 card, see the “DS3/2DS3 NI-2 Card” section on page A-8.

1.2.3.9.1 Faceplate Features

Figure 1-16 shows a close-up of the DS3/2DS3 NI-2 card faceplate.

Figure 1-16 DS3/2DS3 NI-2 Card Faceplate

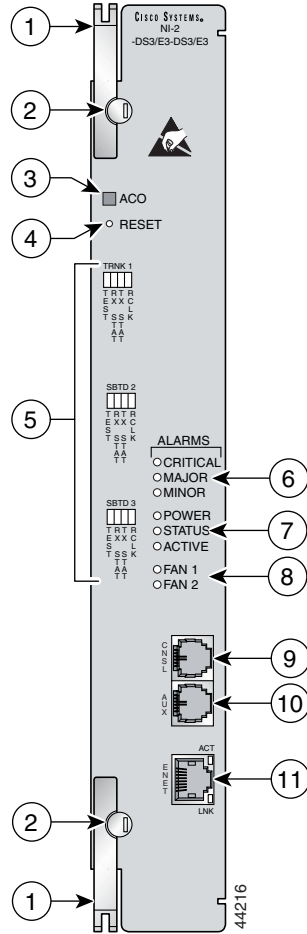

1	Ejector lever	7	Card status LED group
2	Locking tab	8	Fan alarm LED group
3	ACO button	9	CNSL—An RJ-45 receptacle that provides a serial connection to a system console.
4	Maintenance RESET port	10	AUX—An RJ-45 receptacle that provides connection to an auxiliary device (such as a modem) used to remotely configure the system.
5	Interface status LED groups: TRNK ¹ 1, SBTD ² 2, and SBTD 3, which show the status of the network trunk and subtend connections on the I/O module.	11	ENET—An RJ-45 10BaseT receptacle that complies with Ethernet standards and that provides connection to a system Ethernet.
6	System alarm LED group		

1. TRNK = trunk
2. SBTD = subtend

Table 1-10 describes the LED group indicators and their functions.

Table 1-10 DS3/2DS3 NI-2 Card LED Group Indicators

LED Group	LED	State	Function
Interface status LED (5 in Figure 1-16)	TEST	Amber solid	Cisco IOS detects that an obtrusive test (loopback) is active on this interface.
		Off	Cisco IOS does not detect obtrusive test activity.
	RX ¹ STAT	Amber solid	The receiver detects a physical layer problem.
		Off	The receiver does not detect a physical layer problem.
	TX ² STAT	Amber solid	The transmitter detects a physical layer problem.
		Off	The transmitter does not detect a physical layer problem.
RCLK ³	Green solid	Hardware detects an incoming clock signal.	
	Off	Hardware does not detect an incoming clock signal.	
System alarm (6 in Figure 1-16)	CRITICAL	Red	A critical alarm is active.
	MAJOR	Red	A major alarm is active.
	MINOR	Amber	A minor alarm is active.
Card status (7 in Figure 1-16)	POWER	Green	The NI-2 card has power.
	STATUS	Green	The operational status of the NI-2 card. <ul style="list-style-type: none"> • On—There are no internal faults or problems. • Off—The NI-2 card has not booted properly, or a problem is preventing normal operation.
	ACTIVE	Green	The NI-2 card is operating as the active NI-2 card in the chassis.
Fan alarm (8 in Figure 1-16)	FAN 1	Red	The fan module or fan tray is not operational and is in alarm mode.
	FAN 2	Off	The fan tray is off.
ENET interface LED (11 in Figure 1-16)	ACT	Green solid or blinking	The Ethernet interface is active.
		Off	The Ethernet interface is inactive.
	LNK	Green solid	The Ethernet link is connected and enabled.

1. RX = receive
2. TX = transmit
3. RCLK = receive clock

1.2.3.10 DS3+T1/E1 IMA NI-2 Card Overview

The DS3+T1/E1 IMA NI-2 card

- Provides the following network trunk and subtend interfaces:

- E1
- E1 IMA group



Note Network trunk and subtend connectors for the DS3+T1/E1 IMA NI-2 cards are located on the E1 I/O module on the front of the Cisco 6260 chassis.

- Connects to the xTU-C line cards through point-to-point serial data buses on the backplane
- Contains the ATM switch fabric
- Provides CO facility alarm relay contact interfaces and an ACO button
- Provides visual and audible operating status alerts
- Is manageable through Cisco IOS software or CDM
- Provides Cisco IOS-based ATM QoS
- Controls timing through an internal clock or BITS interface, or from an ATM interface (E1)



Note The BITS interface is connected through the I/O module located on the front of the Cisco 6260.

- Supports the aggregation of up to seven subtended node chassis that are configured for E1 or E1 IMA group operation in a daisy-chain, tree, or star topology
- Provides E1 subtend interfaces through RJ-48c connectors located on the E1 I/O module.

1.2.3.10.1 Faceplate Features

Figure 1-17 shows a close-up of the DS3+T1/E1 IMA NI-2 card faceplate.

Figure 1-17 DS3+T1/E1 IMA NI-2 Card Faceplate

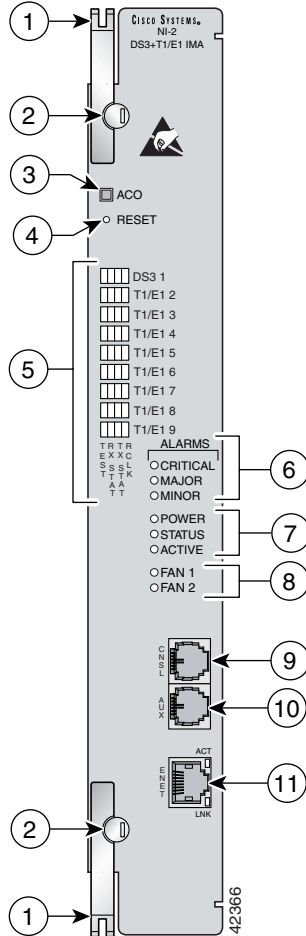

1	Ejector lever	7	Card status LED group
2	Locking tab	8	Fan alarm LED group
3	ACO button	9	CNSL—An RJ-45 receptacle that provides a serial connection to a system console.
4	Maintenance RESET port	10	AUX—An RJ-45 receptacle that provides connection to an auxiliary device (such as a modem) used to remotely configure the system.
5	Interface status LED groups: DS3 1, T1/E1 2, T1/E1 3, T1/E1 4, T1/E1 5, T1/E1 6, T1/E1 7, T1/E1 8, and T1/E1 9, which show the status of the network trunk and subtend connections on the I/O module	11	ENET—An RJ-45 10BaseT receptacle that complies with Ethernet standards and that provides connection to a system Ethernet.
6	System alarm LED group		

Table 1-11 describes the LED group indicators and their functions.

Table 1-11 DS3+T1/E1 IMA NI-2 Card LED Group Indicators

LED Group	LED	State	Function
Interface status LED (5 in Figure 1-17)	TEST	Amber solid	Cisco IOS detects that an obtrusive test (loopback) is active on this interface.
		Off	Cisco IOS does not detect obtrusive test activity.
	RX STAT	Amber solid	The receiver detects a physical layer problem.
		Off	The receiver does not detect a physical layer problem.
	TX STAT	Amber solid	The transmitter detects a physical layer problem.
		Off	The transmitter does not detect a physical layer problem.
RCLK	Green solid	Hardware detects an incoming clock signal.	
	Off	Hardware does not detect an incoming clock signal.	
System alarm (6 in Figure 1-17)	CRITICAL	Red	A critical alarm is active.
	MAJOR	Red	A major alarm is active.
	MINOR	Amber	A minor alarm is active.
Card status (7 in Figure 1-17)	POWER	Green	The NI-2 card has power.
	STATUS	Green	The operational status of the NI-2 card. <ul style="list-style-type: none"> On—There are no internal faults or problems. Off—The NI-2 card has not booted properly, or a problem is preventing normal operation.
	ACTIVE	Green	The NI-2 card is operating as the active NI-2 card in the chassis.
Fan alarm (8 in Figure 1-17)	FAN 1	Red	The fan module or fan tray is not operational and is in alarm mode.
	FAN 2	Red	The fan module or fan tray is not operational and is in alarm mode.
ENET interface LED (11 in Figure 1-17)	ACT	Green solid or blinking	The Ethernet interface is active.
		Off	The Ethernet interface is inactive.
	LNK	Green solid	The Ethernet link is connected and enabled.

1.2.3.11 OC-3c/OC-3c NI-2 Card Overview

The OC-3c/OC-3c NI-2 card

- Provides the network OC-3c network trunk interface through optical connectors located on the NI-2 card faceplate. The following two versions of the OC-3c/OC-3c NI-2 card are available to support the network trunk interface:
 - SMF intermediate range
 - MMF short range
- Connects to the xTU-C line cards through point-to-point serial data buses on the backplane

- Contains the ATM switch fabric
- Provides CO facility alarm relay contact interfaces and an ACO button
- Provides visual and audible operating status alerts
- Is manageable through Cisco IOS software or CDM
- Provides Cisco IOS-based ATM QoS
- Controls timing and redundancy



Note The BITS interface is connected through the OC-3c I/O module located on the front of the Cisco 6260 chassis.

- Supports the aggregation of up to 12 subtended node chassis configured for OC-3c operation in a daisy chain configuration.
- Provides an OC-3c subtend interface through optical connectors located on the NI-2 card faceplate.



Note For hardware specifications for the OC-3c/OC-3c NI-2 card, see the “OC-3c/OC-3c NI-2 Card” section on page A-10.

1.2.3.11.1 Faceplate Features

Figure 1-18 shows a close-up of the OC-3c/OC-3c NI-2 card faceplate.

Figure 1-18 OC-3c/OC-3c NI-2 Card Faceplate

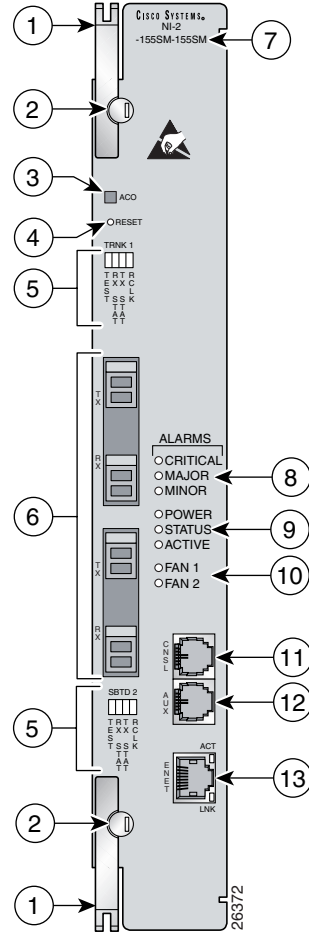

1	Ejector lever	8	System alarm LED group
2	Locking tab	9	Card status LED group
3	ACO button	10	Fan alarm LED group
4	Maintenance RESET port	11	CNSL—An RJ-45 receptacle that provides a serial connection to a system console.

5	Interface status LED groups: TRNK 1 and SBTD 2, which show the status of the network trunk and subtend connections.	12	AUX—An RJ-45 receptacle that provides connection to an auxiliary device (such as a modem) used to remotely configure the system.
6	Two optical interface connector pairs: TRNK 1 and SBTD 2 <ul style="list-style-type: none"> • TRNK 1—for network trunk interface TX and RX data optical cables. On a subtended node chassis, these TX and RX cables connect to SBTD 2 on the subtending host chassis. • SBTD 2—for subtended node chassis TX and RX data optical cables. 	13	ENET—An RJ-45 10BaseT receptacle that complies with Ethernet standards and that provides connection to a system Ethernet.
7	Model number		

Table 1-12 describes the LED group indicators and their functions.

Table 1-12 OC-3c/OC-3c NI-2 Card LED Group Indicators

LED Group	LED	State	Function
Interface status LED (5 in Figure 1-18)	TEST	Amber solid	Cisco IOS detects that an obtrusive test (loopback) is active on this interface.
		Off	Cisco IOS does not detect obtrusive test activity.
	RX STAT	Amber solid	The receiver detects a physical layer problem.
		Off	The receiver does not detect a physical layer problem.
	TX STAT	Amber solid	The transmitter detects a physical layer problem.
		Off	The transmitter does not detect a physical layer problem.
RCLK	Green solid	Hardware detects an incoming clock signal.	
	Off	Hardware does not detect an incoming clock signal.	
System alarm (7 in Figure 1-18)	CRITICAL	Red	A critical alarm is active.
	MAJOR	Red	A major alarm is active.
	MINOR	Amber	A minor alarm is active.
Card status (8 in Figure 1-18)	POWER	Green	The NI-2 card has power.
	STATUS	Green	The operational status of the NI-2 card. <ul style="list-style-type: none"> • On—There are no internal faults or problems. • Off—The NI-2 card has not booted properly, or a problem is preventing normal operation.
	ACTIVE	Green	The NI-2 card is operating as the active NI-2 card in the chassis.

Table 1-12 OC-3c/OC-3c NI-2 Card LED Group Indicators (continued)

LED Group	LED	State	Function
Fan alarm (9 in Figure 1-18)	FAN 1	Red	The fan module or fan tray is not operational and is in alarm mode.
	FAN 2	Red	The fan module or fan tray is not operational and is in alarm mode.
ENET interface LED (12 in Figure 1-18)	ACT	Green solid or blinking	The Ethernet interface is active.
		Off	The Ethernet interface is inactive.
	LNK	Green solid	The Ethernet link is connected and enabled.

1.2.3.12 Network Clocking Overview

The NI-2 card receives its network timing signal from any one of the following sources:

- A BITS clock. When a BITS clock is the network timing signal source, the Cisco 6260 chassis receives a clock signal through designated pins on the I/O module and distributes the signal through the Cisco 6260 backplane.
- An internal clock.
- E3 or OC-3c network trunk interface. An NI-2 card synchronizes with the network timing source and provides a clock reference signal to line cards in the Cisco 6260 chassis and to subtended node chassis.

The active NI-2 card supplies a redundant pair of clock signals to all cards in the chassis. This same clock reference can be propagated to subtended systems via the trunk and subtended interface ports. This is done by configuring the subtending port of the root system to source the network-derived clock. The trunk port of the subtended system is configured as the network clock source for that chassis. This chain continues down the subtended tree.

1.2.3.13 Redundancy Overview

Redundancy is available for the Cisco 6260 system. The following forms of redundancy are available:

- NI-2 card cold redundancy, which allows a standby NI-2 card to take over system operations in the event of a complete failure of the active NI-2 card.
- Automatic protection switching (APS) link redundancy, which is available on OC-3c/OC-3c NI-2 card network trunk and subtend interfaces.



Note

Line card redundancy is not currently supported in the Cisco 6260 system.

1.2.3.13.1 NI-2 Card Redundancy

NI-2 card redundancy requires that two NI-2 cards be installed in the chassis. The primary card is installed in slot 10 of the chassis, and the secondary card is installed in slot 11. Either the primary or the secondary NI-2 card can serve as the active NI-2 card. The interface types must be the same for both the primary and secondary NI-2 cards. The following NI-2 cards support cold redundancy in the Cisco 6260 chassis:

- DS3/2DS3
- DS3+T1/E1 IMA
- OC-3c/OC-3c (SMF and MMF)

During steady-state operations, one NI-2 card functions as the active unit, and the other functions as the standby unit. The active NI-2 card displays a green ACTIVE LED. In an active state, the NI-2 card

- Has full Ethernet, auxiliary port, and console access
- Communicates with line cards
- Has full access to the environmental monitoring subsystem
- Has access to the optical interfaces on the standby NI-2 card
- Allows remote access to the file system of the standby NI-2 card

The standby NI-2 card plays a minimal role during steady-state operations. In a standby state, the NI-2 card

- Receives configuration changes from the active NI-2 card (when the cards are configured for synchronization)
- Has no Ethernet, auxiliary port, or console access
- Does not communicate with line cards
- Has no access to the environmental monitoring subsystem
- Generates only APS alarms, which are reported via the active card

For management purposes, the primary and secondary NI-2 cards appear as one element. The cards share one IP address.

**Note**

For information on NI-2 card cold redundancy switchover conditions, refer to the *Upgrading DSLAMs for NI-2 Card and APS Link Redundancy* document.

1.2.3.13.2 APS Link Redundancy

APS link redundancy provides recovery from a cut fiber or the failure of an OC-3c optical TX or optical RX interface on an NI-2 card. APS link redundancy is available on OC-3c/OC-3c NI-2 card network trunk and subtend interfaces.

APS link redundancy is nonrevertive. After a switchover from the primary to the secondary fiber occurs, the active NI-2 card switches back to the primary fiber only if it is manually forced through a command-line interface (CLI) or if a failure condition occurs on the secondary fiber. However, if a failure condition occurs on the secondary fiber while the primary fiber is still in a failed state, a switch back to the primary fiber does not occur.

**Note**

The OC-3c ports on the standby NI-2 card are available for APS link redundancy only if the standby NI-2 card is working and in a STANDBY-READY state.

For more information on APS link redundancy, refer to the *Upgrading DSLAMs for NI-2 Card and APS Link Redundancy* document.

1.2.3.14 Redundancy in Subtended Configurations

NI-2 card redundancy is supported in an E3 subtend tree or daisy-chain or in an OC-3c subtend daisy-chain if both the subtending host chassis and the subtended node chassis have primary and secondary NI-2 cards installed. An NI-2 card failure on a node in a subtend tree or daisy-chain temporarily interrupts traffic to all subtended node chassis.

NI-2 card redundancy is not supported in DS3+T1/E1 IMA subtended configurations.

APS link redundancy is supported in subtending configurations only if all of the following conditions exist:

1. The subtending host chassis is configured for OC-3c/OC-3c operation;
2. The subtending host chassis has a secondary NI-2 card installed; and
3. The subtended node chassis have primary and secondary OC-3c/OC-3c NI-2 cards installed.

1.2.4 Cisco 6260 I/O Modules

This section contains the following information:

- E3 I/O Module Overview, page 1-41
- E1 I/O Module Overview, page 1-42
- OC-3c I/O Module Overview, page 1-43

A Cisco 6260 chassis must have an I/O module installed. The I/O module is delivered installed near the top of the Cisco 6260 chassis, just below the subscriber connectors. Figure 1-1 shows the location of the I/O module on the Cisco 6260 chassis.

1.2.4.1 E3 I/O Module Overview

The E3 I/O module provides the Cisco 6260 chassis with a network trunk interface connector and connectors to subtend other DSLAMs to the chassis. The E3 I/O module also provides the alarm pinouts and BITS clock input circuits for the Cisco 6260 system.

The E3 I/O module works with the DS3/2DS3 NI-2 card in the Cisco 6260 chassis.



Note The Cisco 6260 does not support the DS3 interface. When the DS3/2DS3 NI-2 card is installed in the Cisco 6260 chassis with an E3 I/O module, the NI-2 card adopts E3 functionality.

Figure 1-19 shows a close-up of the E3 I/O module.

Figure 1-19 E3 I/O Module

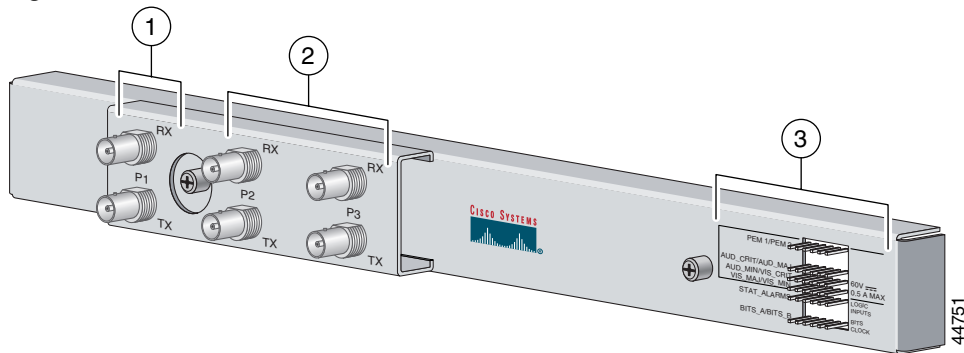

1	E3 75-ohm coaxial BNC connectors. The P1 RX and TX connectors serve as the network trunk interface.	3	Six rows of six wire-wrap pins that support CO alarm relay interfaces and BITS clock input circuits.
2	E3 75-ohm coaxial BNC connectors. The P2 and P3 RX and TX connectors serve as subtend connectors to additional chassis.		

**Note**

For hardware specifications for the E3 I/O module, see the “I/O Module” section on page A-11.

1.2.4.2 E1 I/O Module Overview

The E1 I/O module provides eight E1 interfaces that can be allocated as either individual E1 network trunk or subtend interfaces, or as IMA group trunk or subtend interfaces. The E1 I/O module also provides the alarm pinouts and BITS clock input circuits for the Cisco 6260 system.

The E1 I/O module works with the DS3+T1/E1 IMA NI-2 card in the Cisco 6260 chassis.

Figure 1-20 shows a close-up of the E1 I/O module.

Figure 1-20 E3 I/O Module

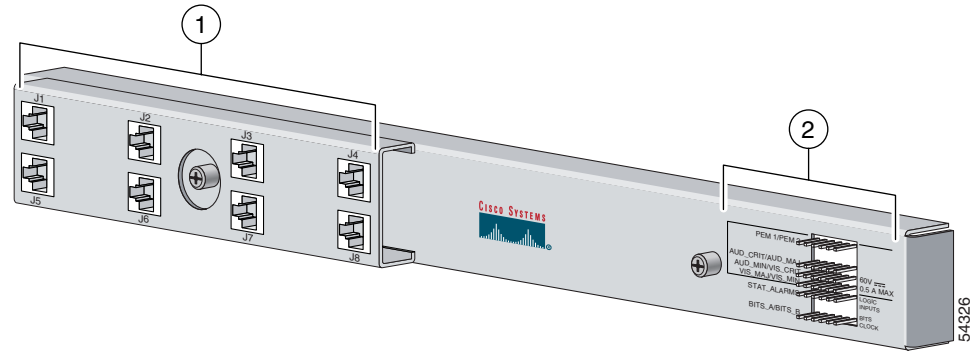

1	Four sets of two vertically-paired E1 120-ohm RJ-48c connectors that can be used as a network trunk connection, an individual E1 subtend link, a connection to an IMA subtending group, or a connection to an IMA group trunk interface.	2	Six rows of six wire-wrap pins that support CO alarm relay interfaces and BITS clock input circuits.
----------	--	----------	--

Note

For hardware specifications for the E1 I/O module, see the “I/O Module” section on page A-11.

1.2.4.3 OC-3c I/O Module Overview

No network trunk or subtending port connectors are needed on the OC-3c I/O module. These connectors are present on the OC-3c/OC-3c NI-2 card faceplate.

The OC-3c I/O module works with the OC-3c/OC-3c NI-2 card in the Cisco 6260 chassis.

Figure 1-21 shows a close-up of the OC-3c I/O module, including the wire-wrap pins located on the right side of the I/O module faceplate that support CO alarm relay interfaces and BITS clock input circuits.

Figure 1-21 OC-3c I/O Module

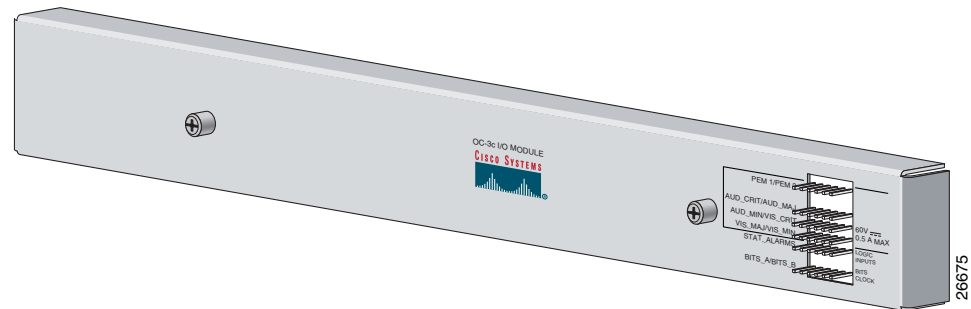

Note

For hardware specifications for the OC-3c I/O module, see the “I/O Module” section on page A-11.

1.2.4.4 I/O Module Wire-Wrap Pins

Located on the right side of each I/O module faceplate are 36 wire-wrap pins that support

- Central office alarm relay interfaces (visual and audible critical, major, and minor)
- BITS clock input circuits
- Wire-wrap and socket-type connections

Both the alarm relay and the BITS clock connections are optional. If you connect the alarm relays, they transmit critical, major, and minor alarms to a separate, external alarm device. The alarm device uses a bell, light, or some other signal to alert service personnel to the change in system status. If you connect the BITS interface, the Cisco 6260 can receive a clock signal from an E1 line.

Figure 1-22 shows a close-up of the wire-wrap pins.

Figure 1-22 I/O Module Wire-Wrap Pins Close-Up

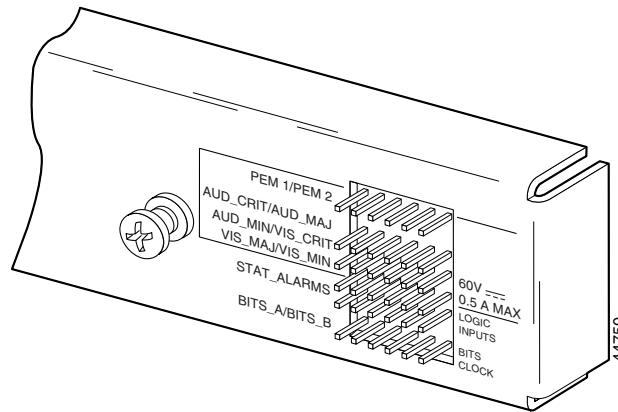

These pins support the following items:

- Visual critical alarm
- Visual major alarm
- Visual minor alarm
- Audible critical alarm
- Audible major alarm
- Audible minor alarm
- Power module alarms
- Remote alarm cut off
- Reserved (several pins are reserved for future specification)

Each of the wire-wrap pins is connected to the NI-2 cards in the Cisco 6260 chassis; however, only one NI-2 card manages the alarms. The ACO switch on the NI-2 card faceplate shuts off the audible alarms generated by the Cisco 6260 system software.

One of the alarm relay functions provided by the wire-wrap connector is an ACO circuit that you can wire to your external alarm device. To use this feature, connect the alarm device so that it can close the contact between pin 5 and pin 6 in row 5.

The connector also provides contacts for the following features, all of which can be used separately:

- Audible alarms—Wire pins whose signals begin with AUD
- Visible alarms—Wire pins whose signals begin with VIS
- Power alarms—Wire pins whose signals begin with PEM
- BITS clock—Wire pins whose signals begin with RX_BITS

**Note**

There is one set of contacts for audible alarms and one set for visual alarms. You can use either or both sets of contacts.

You can wire the alarm relay contacts as normally open (NO) or normally closed (NC). (One exception is the ACO circuit, which can be wired as NO only.) Use common (CO) pins for both the NO and NC wiring methods.

Table 1-13 Pin Assignments for the Cisco 6260 I/O Module

Wiring Method	Pins to Use
Normally open	Pin 2 in rows 1, 2, 3, 4 (NO) Pin 5 in rows 1, 2, 3, 4, 5 (NO) Pin 1 in rows 1, 2, 3, 4 (CO) Pin 4 in rows 1, 2, 3, 4 (CO) Pin 6 in row 5 (GND ¹)
Normally closed	Pin 3 in rows 1, 2, 3, 4 (NC) Pin 6 in rows 1, 2, 3, 4 (NC) Pin 1 in rows 1, 2, 3, 4 (CO) Pin 4 in rows 1, 2, 3, 4 (CO)

1. GND = ground

**Note**

For more information on how the wire-wrap pins map to the alarms, see the “Port Mapping Table” section on page B-1.

1.2.5 PEM

The Cisco 6260 system is equipped with one or two –48/–60V direct current (DC) PEMs, which distribute DC power within the chassis. The Cisco 6260 requires only one active PEM to operate; if two PEMs are installed, the second PEM serves as a hot backup to the first.

Each PEM should be connected to a single DC power source. DC power (–48V) enters the chassis through the terminal blocks on the front of each PEM. For full power redundancy, two PEMs must be installed in the chassis, and the two PEMs must be connected to two separate DC power sources.

In a system with two PEMs installed, you can remove and replace each individual PEM while the system continues to operate. (A system with a single PEM must be powered down before the PEM is removed.)

In addition, you can replace a PEM in a chassis with a single PEM installed without shutting down system power by first removing the blank faceplate from the second slot, installing a replacement PEM in the second slot, and then removing the first PEM. The blank faceplate can then be installed in the empty first PEM slot.

**Note**

The PEMs reside at the bottom of the chassis, and they are installed and accessed from the front (see Figure 1-1 for the location of the PEM in the Cisco 6260 chassis). Each PEM is held in place by the overhanging lip of the fan tray above it. You must remove the fan tray before you can remove the PEM.

To turn off a Cisco 6260 that has two PEMs, you must flip the circuit breakers on *both* PEMs to the OFF (0) position.

The Cisco 6260 can be ordered with only one PEM installed, and with a blank faceplate installed in place of a second PEM.

Figure 1-23 shows a close-up of the PEM faceplate.

Figure 1-23 PEM Faceplate

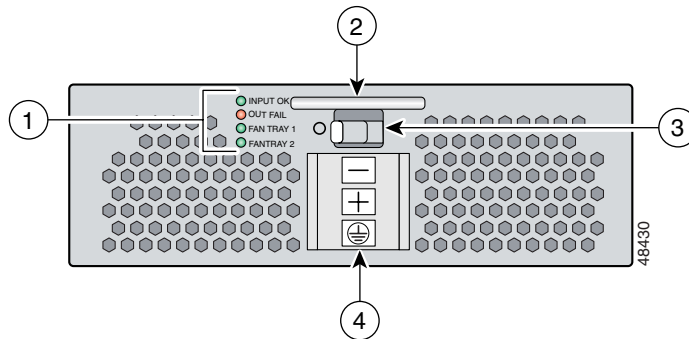

1	PEM and fan tray status LEDs	3	Two-position circuit breaker—the positions are Off (0) and On (1)
2	Extraction handle	4	Negative (-), positive (+), and ground DC power terminal blocks

**Note**

For hardware specifications for the PEM, see the “PEM” section on page A-11.

Table 1-14 describes the PEM LED indicators and their functions.

Table 1-14 PEM LEDs

LED	State	Function
Input OK	Green	–48V power is available to the chassis.
Out Fail	Red	The PEM is not distributing power to the chassis.
Fan Tray 1	Green	The fans in this tray are operating normally.
	Red	One or more fans in this tray have failed.
Fan Tray 2	Green	The fans in this tray are operating normally.
	Red	One or more fans in this tray have failed.

1.2.6 Fan Tray

Two fan trays are installed in the Cisco 6260 chassis below the line cards. Each tray houses four fans. The compartments for the two fan trays are located side by side near the bottom of the chassis, just above the PEMs (see Figure 1-1 for the location of the fan trays in the Cisco 6260 chassis). As you face the chassis, fan tray 1 is on the left; and fan tray 2 is on the right.

A narrow bezel fits across the chassis to hold the air filters and fan trays in place.

Note

The Cisco 6260 system requires that a fan tray be installed when the system is in operation.

Figure 1-24 shows a close-up view of the fan tray.

Figure 1-24 Cisco 6260 Fan Tray

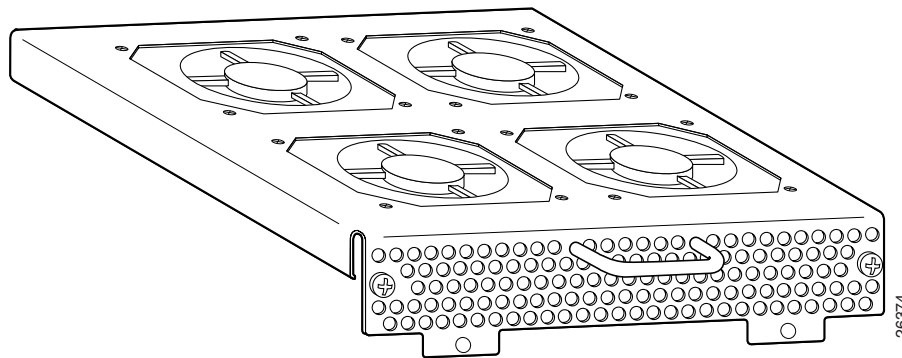

The fans have two speeds. By default, they run at low speed. The system turns up the fan speed when

- It senses high temperatures within the chassis.
- One or more fans fail.
- The other fan tray is removed.

The fan speed returns to normal (low speed) when

- Temperatures within the chassis fall to acceptable levels.
- A missing fan tray is reinstalled in the chassis.

Caution

The fans in both fan trays must run continuously. The system might suffer thermal damage if the fans in either tray stop for more than 5 minutes.

An air filter is located above each fan tray. The air filters must be removed and cleaned periodically. See the “Replacing or Cleaning the Air Filter” section on page 6-2 for instructions on cleaning the air filters.



Note

For hardware specifications for the fan tray, see the “Fan Tray” section on page A-12.

1.2.7 Air Filters

Two air filters are located at the bottom of the Cisco 6260 chassis. The air filters must be removed and cleaned periodically. See Chapter 6, “Upgrading and Maintaining the Cisco 6260 System,” for complete instructions on cleaning and replacing the air filter. Figure 1-25 shows the location of the air filters and the protective bezel that covers them.

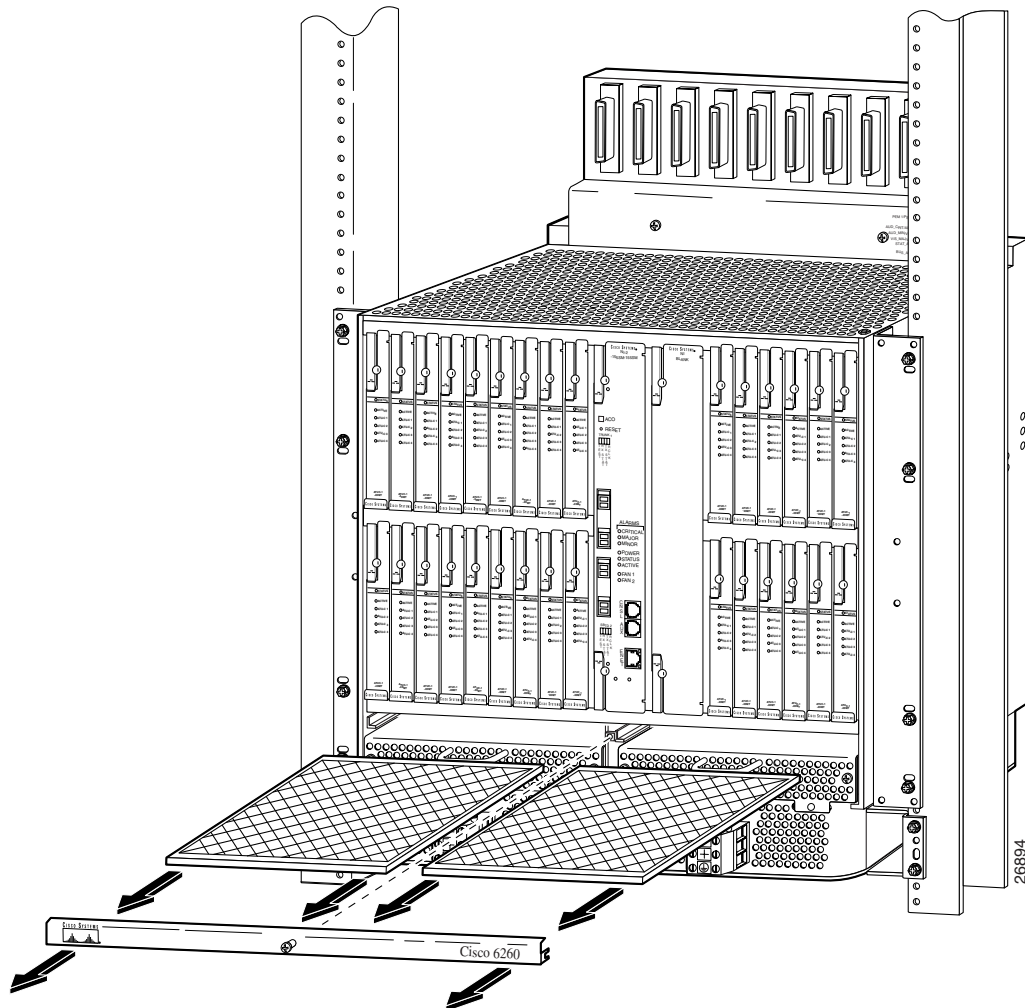
Figure 1-25 Air Filters



1.2.8 ESD Jack

An electrostatic discharge (ESD) jack is located on the top of the chassis at the right front corner. Before removing any components from the chassis or installing any components, ground yourself by using the ESD jack.

1.2.9 Third-Party POTS Splitter

For information about the third-party POTS splitter, refer to the vendor documentation.

1.3 Management Software

You can provision and manage the Cisco 6260 system through the following management software:

- Cisco IOS—A command-line interface (CLI) that is available for network element provisioning.
- Cisco DSL Manager (CDM)—An element management system designed to configure and manage the 6xxx series of Cisco IOS software-based DSLAMs through a graphical-user interface (GUI). CDM provides the following areas of network management: fault, configuration, performance, and security. CDM runs within the Cisco Element Manager Framework (EMF); both are installed on Sun workstations.

Cisco EMF is based on an object model in which network elements or modules represent the managed entity. Each object is defined by a class and specific attributes. An object can represent a network element or a more abstract entity such as a link relationship, a network, or a container such as a site, shelf, or region.

**Note**

If your network contains multiple SUN workstations, you must dedicate one workstation as the server and use all additional workstations as clients. The server should be the repository and distributor of database information from which the clients request information. The client workstations allow multiple users to monitor the managed network.

1.3.1 Management Software-Generated Alarms

The Cisco 6260 includes CO alarm LED indicators and relays that indicate system status. You can wire CO facility alarm relay contacts for either normally open or normally closed operations. The supported alarms that are generated by the management software are:

- **CRITICAL**—A critical condition is indicated when the CRITICAL LED in the NI-2 card faceplate lights.
 - When a critical alarm occurs, the critical visual and audible alarm relays are activated.
 - A critical alarm affects many or all subscribers that are connected to the node. (For example, failure of the NI-2 card or the network trunk connection can cause a critical alarm.)
 - Critical alarms clear after you fix the condition that triggered the alarm.
 - Audible alarms are turned off when you press the ACO button on the NI-2 card faceplate or clear the alarm in the Cisco IOS software.
- **MAJOR**—A major alarm condition is indicated when the MAJOR LED in the NI-2 card faceplate lights.
 - When a major alarm occurs, the major visual and audible alarm relays are also activated.
 - Many of the subscribers that are connected to the node are affected.
 - Major alarms clear after you fix the condition that triggered the alarm.

- Audible alarms are turned off when you press the ACO button on the NI-2 card faceplate or clear the alarm in the Cisco IOS software.
- MINOR—A minor alarm condition is indicated when the MINOR LED in the NI-2 card faceplate lights.
 - When a minor alarm occurs, the minor visual and audible alarm relays are also activated.
 - A small number of subscribers that are connected to the node are affected.
 - Minor alarms clear after you fix the condition that triggered the alarm.
 - Audible alarms are turned off when you press the ACO button on the NI-2 card faceplate or clear the alarm in the Cisco IOS software.

Visual and audible alarm relay contacts can be wired from the Cisco 6260 to CO alarm devices (remote lights or bells, for example) located anywhere within the facility.

The visual and audible alarm relays are located on the I/O module, but the NI-2 card hardware operates them.

For more information about alarms that are generated in the management software, see Chapter 5, “Troubleshooting.”



Preparing for Installation

This chapter tells you how to prepare for the installation of the Cisco 6260 system.

The chapter contains the following sections:

- Safety Requirements, page 2-1
- Site Requirements, page 2-11
- Required Tools and Equipment, page 2-16
- Unpacking the Cisco 6260 System, page 2-18
- Verifying Contents, page 2-18
- Inspecting for Damage, page 2-18



Caution

Before you start the installation procedures, read the entire chapter for important information and safety warnings.

2.1 Safety Requirements

This section describes safety requirements for the Cisco 6260 system. Before you install the Cisco 6260 system, ensure that all the criteria in this section are met. The section describes the following safety requirements:

- Safety Guidelines, page 2-1
- Preventing Electrostatic Discharge Damage, page 2-9
- General Maintenance Guidelines, page 2-10

2.1.1 Safety Guidelines

Before working on the equipment, be aware of standard safety guidelines and the hazards that are involved in working with electrical circuitry to prevent accidents. Adhere to the following cautions and warnings and those throughout the guide for safe and hazard-free installation.



Note

To see translations of the warnings that appear in this publication, refer to the *Regulatory Compliance and Safety Information for the Cisco 6260 System* document.

**Caution**

Installing the cards in the chassis with the power leads reversed can damage the line cards.

**Caution**

If fuses are already installed in the fuse and alarm panel, remove them. You can replace the fuses after the system is installed. Do not power up the system while you install and connect the system.

**Caution**

If the power connections are improperly made and power is applied while the cards are installed, the cards and chassis could be damaged.

**Caution**

It is important that the chassis cooling fans run continuously.

**Caution**

Any card that is only partially connected to the backplane can disrupt system operation.

2.1.2 Warning Definition

**Warning**

This warning symbol means *danger*. You are in a situation that could cause bodily injury. Before you work on any equipment, be aware of the hazards involved with electrical circuitry and be familiar with standard practices for preventing accidents. To see translations of the warnings that appear in this publication, refer to the *Regulatory Compliance and Safety Information* document that accompanied this device.

Waarschuwing

Dit waarschuwingssymbool betekent gevaar. U verkeert in een situatie die lichamelijk letsel kan veroorzaken. Voordat u aan enige apparatuur gaat werken, dient u zich bewust te zijn van de bij elektrische schakelingen betrokken risico's en dient u op de hoogte te zijn van standaard maatregelen om ongelukken te voorkomen. Voor vertalingen van de waarschuwingen die in deze publicatie verschijnen, kunt u het document *Regulatory Compliance and Safety Information* (Informatie over naleving van veiligheids- en andere voorschriften) raadplegen dat bij dit toestel is ingesloten.

Varoitus

Tämä varoitusmerkki merkitsee vaaraa. Olet tilanteessa, joka voi johtaa ruumiinvammaan. Ennen kuin työskentelet minkään laitteiston parissa, ota selvää sähkökytkentöihin liittyvistä vaaroista ja tavanomaisista onnettomuuksien ehkäisykeinoista. Tässä julkaisussa esiintyvien varoitusten käännökset löydät laitteen mukana olevasta *Regulatory Compliance and Safety Information* -kirjastesta (määräysten noudattaminen ja tietoa turvallisuudesta).

Attention	Ce symbole d'avertissement indique un danger. Vous vous trouvez dans une situation pouvant causer des blessures ou des dommages corporels. Avant de travailler sur un équipement, soyez conscient des dangers posés par les circuits électriques et familiarisez-vous avec les procédures couramment utilisées pour éviter les accidents. Pour prendre connaissance des traductions d'avertissements figurant dans cette publication, consultez le document <i>Regulatory Compliance and Safety Information</i> (Conformité aux règlements et consignes de sécurité) qui accompagne cet appareil.
Warnung	Dieses Warnsymbol bedeutet Gefahr. Sie befinden sich in einer Situation, die zu einer Körperverletzung führen könnte. Bevor Sie mit der Arbeit an irgendeinem Gerät beginnen, seien Sie sich der mit elektrischen Stromkreisen verbundenen Gefahren und der Standardpraktiken zur Vermeidung von Unfällen bewusst. Übersetzungen der in dieser Veröffentlichung enthaltenen Warnhinweise finden Sie im Dokument <i>Regulatory Compliance and Safety Information</i> (Informationen zu behördlichen Vorschriften und Sicherheit), das zusammen mit diesem Gerät geliefert wurde.
Avvertenza	Questo simbolo di avvertenza indica un pericolo. La situazione potrebbe causare infortuni alle persone. Prima di lavorare su qualsiasi apparecchiatura, occorre conoscere i pericoli relativi ai circuiti elettrici ed essere al corrente delle pratiche standard per la prevenzione di incidenti. La traduzione delle avvertenze riportate in questa pubblicazione si trova nel documento <i>Regulatory Compliance and Safety Information</i> (Conformità alle norme e informazioni sulla sicurezza) che accompagna questo dispositivo.
Advarsel	Dette varselsymbolet betyr fare. Du befinner deg i en situasjon som kan føre til personskade. Før du utfører arbeid på utstyr, må du være oppmerksom på de faremomentene som elektriske kretser innebærer, samt gjøre deg kjent med vanlig praksis når det gjelder å unngå ulykker. Hvis du vil se oversettelser av de advarslene som finnes i denne publikasjonen, kan du se i dokumentet <i>Regulatory Compliance and Safety Information</i> (Overholdelse av forskrifter og sikkerhetsinformasjon) som ble levert med denne enheten.
Aviso	Este símbolo de aviso indica perigo. Encontra-se numa situação que lhe poderá causar danos físicos. Antes de começar a trabalhar com qualquer equipamento, familiarize-se com os perigos relacionados com circuitos eléctricos, e com quaisquer práticas comuns que possam prevenir possíveis acidentes. Para ver as traduções dos avisos que constam desta publicação, consulte o documento <i>Regulatory Compliance and Safety Information</i> (Informação de Segurança e Disposições Reguladoras) que acompanha este dispositivo.
¡Advertencia!	Este símbolo de aviso significa peligro. Existe riesgo para su integridad física. Antes de manipular cualquier equipo, considerar los riesgos que entraña la corriente eléctrica y familiarizarse con los procedimientos estándar de prevención de accidentes. Para ver una traducción de las advertencias que aparecen en esta publicación, consultar el documento titulado <i>Regulatory Compliance and Safety Information</i> (Información sobre seguridad y conformidad con las disposiciones reglamentarias) que se acompaña con este dispositivo.
Varning!	Denna varningssymbol signalerar fara. Du befinner dig i en situation som kan leda till personskada. Innan du utför arbete på någon utrustning måste du vara medveten om farorna med elkretsar och känna till vanligt förfarande för att förebygga skador. Se förklaringar av de varningar som förekommer i denna publikation i dokumentet <i>Regulatory Compliance and Safety Information</i> (Efterrättelse av föreskrifter och säkerhetsinformation), vilket medföljer denna anordning.

**Warning**

Before opening the chassis, disconnect the telephone-network cables to avoid contact with telephone-network voltages.

**Warning**

Do not work on the system or connect or disconnect cables during periods of lightning activity.

**Warning**

Read the installation instructions before you connect the system to its power source.

**Warning**

For personal safety, the ground wire must connect to safety (earth) ground at both the equipment and supply side of the DC wiring (unless the local electrical code requirements are different).

**Warning**

Incorrect connection of this or connected equipment to a general purpose outlet could result in a hazardous situation.

**Warning**

Do not touch the power supply when the power cord is connected. For systems with a power switch, line voltages are present within the power supply even when the power switch is off and the power cord is connected. For systems without a power switch, line voltages are present within the power supply when the power cord is connected.

**Warning**

Secure all power cabling when installing this unit to avoid disturbing field-wiring connections.

**Warning**

The power supply circuitry for the equipment can constitute an energy hazard. Before you install or replace the equipment, remove all jewelry (including rings, necklaces, and watches). Metal objects can come into contact with exposed power supply wiring or circuitry inside the DSLAM equipment. This could cause the metal objects to heat up and cause serious burns or weld the metal object to the equipment.

**Warning**

The customer 48 volt power system must provide reinforced insulation between the primary AC power and the 48 VDC output.

**Warning**

Hold the PEM by the sheet-metal carrier (top and front) only. Internal components may be hot.

**Warning**

Before working on a chassis or working near power supplies, unplug the power cord on AC units; disconnect the power at the circuit breaker on DC units.

**Warning**

Care must be given to connecting units to the supply circuit so that wiring is not overloaded.

**Warning**

Network hazardous voltages are present in the T1 PRI cable. If you detach the cable, detach the end away from the router first to avoid possible electric shock. Network hazardous voltages are also present in the area of the T1 PRI (RJ-48C) ports, regardless of whether power is off or on.

**Warning**

The telecommunications lines must be disconnected 1) before unplugging the main power connector or 2) while the housing is open.

**Warning**

Hazardous network voltages are present in WAN ports regardless of whether power to the router is OFF or ON. To avoid electric shock, use caution when working near WAN ports. When detaching cables, detach the end away from the router first.

**Warning**

To reduce the risk of electric shock when servicing any individual unit, disconnect the power cord or cords that connect the unit to the AC powerstrip or DC busbar. When working with a DC system, remove the busbar connector before working on a device. Exposed live voltages are present at the device end; exposure to these may cause injury.

**Warning**

A voltage mismatch can cause equipment damage and may pose a fire hazard. If the voltage indicated on the label is different from the power outlet voltage, *do not connect the chassis to that receptacle.*

**Warning**

To prevent bodily injury when mounting or servicing this unit in a rack, you must take special precautions to ensure that the system remains stable. The following guidelines are provided to ensure your safety:

—This unit should be mounted at the bottom of the rack if it is the only unit in the rack.

—When mounting this unit in a partially filled rack, load the rack from the bottom to the top with the heaviest component at the bottom of the rack.

—If the rack is provided with stabilizing devices, install the stabilizers before mounting or servicing the unit in the rack.

**Warning**

The ports labeled "Ethernet," "10BaseT," "Token Ring," "Console," and "AUX" are safety extra-low voltage (SELV) circuits. SELV circuits should only be connected to other SELV circuits. Because the BRI circuits are treated like telephone-network voltage, avoid connecting the SELV circuit to the telephone network voltage (TNV) circuits.

**Warning**

Ethernet cables must be shielded when used in a central office environment.

**Warning**

An exposed wire lead from a DC-input power source can conduct harmful levels of electricity. Be sure that no exposed portion of the DC-input power source wire extends from the terminal block plug.

**Warning**

This equipment is intended to be grounded. Ensure that the host is connected to earth ground during normal use.

**Warning**

Metal objects heat up when connected to power and ground, and can cause serious burns.

**Warning**

To prevent personal injury or damage to the chassis, lift the unit only by grasping the chassis underneath its lower edge.

**Warning**

Never attempt to lift the chassis with the handles on the power supplies, fan trays, or the switching modules. These handles are not designed to support the weight of the chassis. Using them to lift or support the chassis can result in severe damage to the equipment and serious bodily injury.

**Warning**

Two people are required to lift the chassis. Use the handles on the chassis sides. To prevent injury, keep your back straight and lift with your legs, not your back. To prevent damage to the chassis and components, never attempt to lift the chassis with the handles on the power supplies, the filter module, or on the blower assembly. These handles are not designed to support the weight of the chassis.

**Warning**

If you use wiring terminations, use only the recommended ferrules. These terminations should be the appropriate size for the wires and should clamp the conductor firmly.

**Warning**

Before connecting or disconnecting ground or power wires to the chassis, ensure that power is removed from the DC circuit. To ensure that all power is OFF, locate the circuit breaker on the panel board that services the DC circuit, switch the circuit breaker to the OFF position, and tape the switch handle of the circuit breaker in the OFF position. Use a voltmeter to test for 0 (zero) voltage at the power terminals on the chassis.

**Warning**

This unit has more than one power supply connection; all connections must be removed completely to completely remove power from the unit.

**Warning**

Only a DC power source that is isolated from AC mains with reinforced insulation, and that complies with the other safety extra-low voltage (SELV) requirements in one or more of the following: UL 60950, UL1950, CSA 950, EN 60950, and IEC950, can be connected to a Cisco 6260 system. This requirement ensures that in a catastrophic power source fault condition, hazardous voltages are not present on power terminals and connectors.

Warning

Class 1 laser product.

Warning

Do not stare into the beam or view it directly with optical instruments.

Warning

This unit is intended for installation in restricted access areas. A restricted access area is where access can only be gained by service personnel through the use of a special tool, lock and key, or other means of security, and is controlled by the authority responsible for the location.

Warning

When installing the unit, always make the ground connection first and disconnect it last.

Warning

This equipment is to be installed and maintained by service personnel only as defined by AS/NZS 3260 Clause 1.2.14.3 Service Personnel.

Warning

A readily accessible two-poled disconnect device must be incorporated in the fixed wiring.

Warning

To reduce the risk of fire, use only No. 26 AWG or larger telecommunication line cord.

Warning

Never defeat the ground conductor or operate the equipment in the absence of a suitably installed ground conductor. Contact the appropriate electrical inspection authority or an electrician if you are uncertain that suitable grounding is available.

Warning

During this procedure, wear grounding wrist straps to avoid ESD damage to the card. Do not directly touch the backplane with your hand or any metal tool, or you could shock yourself.

Warning

Use copper conductors only.

Warning

Blank faceplates and cover panels serve three important functions: they prevent exposure to hazardous voltages and currents inside the chassis; they contain electromagnetic interference (EMI) that might disrupt other equipment; and they direct the flow of cooling air through the chassis. Do not operate the system unless all cards, faceplates, front covers, and rear covers are in place.

Warning

Only trained and qualified personnel should be allowed to install, replace, or service this equipment.

**Warning**

Connect the unit only to DC power source that complies with the Safety Extra-Low Voltage (SELV) requirements in IEC 60950 based safety standards.

**Warning**

Do not use this product near water; for example, near a bathtub, washbowl, kitchen sink or laundry tub, in a wet basement, or near a swimming pool.

**Warning**

Never install telephone wiring during an electrical storm.

**Warning**

Never install telephone jacks in wet locations unless the jack is specifically designed for wet locations.

**Warning**

Never touch uninsulated telephone wires or terminals unless the telephone line has been disconnected at the network interface.

**Warning**

Use caution when installing or modifying telephone lines.

**Warning**

Avoid using a telephone (other than a cordless type) during an electrical storm. There may be a remote risk of electric shock from lightning.

**Warning**

Do not use a telephone to report a gas leak in the vicinity of the leak.

**Warning**

To prevent personal injury or damage to the chassis, never attempt to lift or tilt the chassis using the handles on the port adapters; these types of handles are not designed to support the weight of the unit. Lift the unit only by grasping the chassis underneath its lower edge.

**Warning**

This equipment needs to be grounded. Use a green and yellow 14 AWG ground wire to connect the host to earth ground during normal use.

**Warning**

This is a Class A product based on the standard of the Voluntary Control Council for Interference by Information Technology Equipment (VCCI). If this equipment is used in a domestic environment, radio disturbance may arise. When such trouble occurs, the user may be required to take corrective actions.

**Warning**

The DS3 ports are not intended to be connected to cables that run outside the building where it is installed. For any connections outside the building, the DS3 ports must be connected to a network termination unit (NTU). NTU devices should comply with appropriate national safety standards such as UL 1950, CSA 950, EN 60950, IEC 950, and AS 3260.

**Warning**

This product requires short-circuit (overcurrent) protection, to be provided as part of the building installation. Install only in accordance with national and local wiring regulations.

**Warning**

High-performance devices on this card can get hot during operation. To remove the card, hold it by the faceplate and bottom edge. Allow the card to cool before touching any other part of it or before placing it in an antistatic bag.

**Warning**

Do not reach into a vacant slot or chassis while you install or remove a module or a fan. Exposed circuitry could constitute an energy hazard.

2.1.3 Preventing Electrostatic Discharge Damage

Proper electrostatic discharge (ESD) protection is required whenever you handle Cisco equipment. ESD damage, which can occur when electronic cards or components are improperly handled, results in complete or intermittent failures. Use an antistatic strap during handling.

Follow these guidelines to prevent ESD damage:

- Always use an ESD ankle or wrist strap and ensure that it makes good skin contact.
- Connect the equipment end of the strap to the ESD jack on the top of the chassis at the right front corner.
- When you install a component, use available ejector levers or captive installation screws to properly seat the bus connectors in the backplane or midplane. These devices prevent accidental removal, provide proper grounding for the system, and help to ensure that bus connectors are properly seated.
- When you remove a component, use available ejector levers or captive installation screws to release the bus connectors from the backplane or midplane.
- Handle the I/O module by the edges only; avoid touching the printed circuit boards or connectors.
- Avoid touching the printed circuit boards or connectors on the NI-2 cards or line cards.
- Place a removed component board-side-up on an antistatic surface or in a static-shielding container. If you plan to return the component to the factory, immediately place it in a static-shielding container.
- Avoid contact between the printed circuit boards and clothing. The wrist strap protects components from ESD voltages on the body only; ESD voltages on clothing can still cause damage.

**Caution**

Periodically check the resistance value of the antistatic strap. Ensure that the measurement is between 1 and 10 megohms.

2.1.4 General Maintenance Guidelines

This section covers the following topics:

- Hot Swapping Cards, page 2-10
- Hot Swapping I/O Modules, page 2-10
- Installation and Replacement Suggestions, page 2-11

2.1.4.1 Hot Swapping Cards

Hot swapping allows you to remove and replace cards without disconnecting the system power. The Cisco 6260 chassis supports hot swapping for the following cards:

- Quad-port DMT ATU-C (4xDMT)
- Quad-port DMT ATU-C over ISDN (4xDMT over ISDN)
- Quad-port flexi ATU-C (4xflexi)
- Quad-port STU-C (4xSDSL)
- Octal-port DMT ATU-C (8xDMT)
- Octal-port DMT ATU-C (8xDMT over ISDN)
- Octal-port G.SHDSL SHTU-C (8xG.SHDSL)

When the system detects that you have added or removed a line card, it automatically runs diagnostic and discovery routines and acknowledges the presence or absence of the line card. If you remove and replace a line card with one of the same type, the newly installed line card receives the same provisioning as the original card. The system resumes operation without any operator intervention.

**Note**

Hot swapping line cards interrupts service for the subscribers assigned to that line card.

The Cisco 6260 also supports hot swapping for the DS3/2DS3 and OC-3c/OC-3c NI-2 cards. Hot swapping active NI-2 cards interrupts service for the entire system until the NI-2 card is replaced or until a redundant NI-2 takes over system operations. However, you can hot swap standby NI-2 cards without interrupting service.

2.1.4.2 Hot Swapping I/O Modules

Hot swapping allows you to remove and replace an I/O module without disconnecting the system power. The Cisco 6260 chassis supports hot swapping for the I/O module, but removing the I/O module interrupts the service for the entire system until it is replaced.

**Caution**

The I/O module must be installed and replaced by a trained technician only.

2.1.4.3 Installation and Replacement Suggestions

The following are recommended installation and replacement practices for the Cisco 6260 system cards and modules.

**Caution**

Any card that is only partially connected to the backplane can disrupt system operation.

- Do not force the line card into its slot. This action can damage the pins on the backplane if they are not aligned properly with the card.
- Ensure that the card is straight and not at an angle when you install the card in the slot. Installing the card at an angle can damage the card. Use the guide rails to install the card correctly.
- Fully depress the ejector tabs to ensure that the card connector mates with the backplane correctly. Firmly seat the card in the slot by locking the card.
- Ensure that the I/O module is straight and parallel to the top of the chassis when you attach the module to the chassis. The pins on the connectors can be damaged if the module is not installed correctly.

2.2 Site Requirements

This section describes requirements for the site at which the Cisco 6260 system is to be installed. Before you install the Cisco 6260 system, ensure that all the criteria in this section are met. The section describes the following:

- Environmental Requirements, page 2-11
- Power Requirements, page 2-14
- Rack-Mounting Requirements, page 2-15

2.2.1 Environmental Requirements

Proper operation of the Cisco 6260 system depends on a proper environment. Before you install the Cisco 6260 system, ensure that all the criteria in this section are met. This section describes the following environmental requirements:

- Temperature, Altitude, and Humidity, page 2-12
- Ventilation, page 2-12
- Space, page 2-13

2.2.1.1 Temperature, Altitude, and Humidity

The Cisco 6260 system can tolerate a wide range of temperatures. Table 2-1 provides the Cisco recommendations for temperature, altitude, and humidity conditions in a central office (CO) environment.

Table 2-1 CO Operating Environment Requirements

Environmental Specifications	Description
Temperature	41° to 104°F (5° to 40°C)—Operating 23° to 131°F (–5° to 55°C)—Short-term operating
Altitude	0 to 10,000 ft (0 to 3048 m)
Humidity	5 to 95% (noncondensing)



Warning

To prevent the system from overheating, do not operate it in an area that exceeds the maximum recommended ambient temperature of 104°F (40°C).

2.2.1.2 Ventilation

The Cisco 6260 fans maintain a suitable operating temperature for the internal circuitry. Ensure that the air intake vents at the lower front of the chassis and the air exhaust vents on the top of the chassis are not obstructed in any way.

The third-party POTS splitters do not dissipate heat and should be positioned at the bottom of the rack.

The air intake vents are located at the bottom front of the chassis, and the air exhaust vents are located on top of the chassis, as depicted in Figure 2-1.

Figure 2-1 Air Flow Through Intake and Exhaust Vents on the Cisco 6260 Chassis.

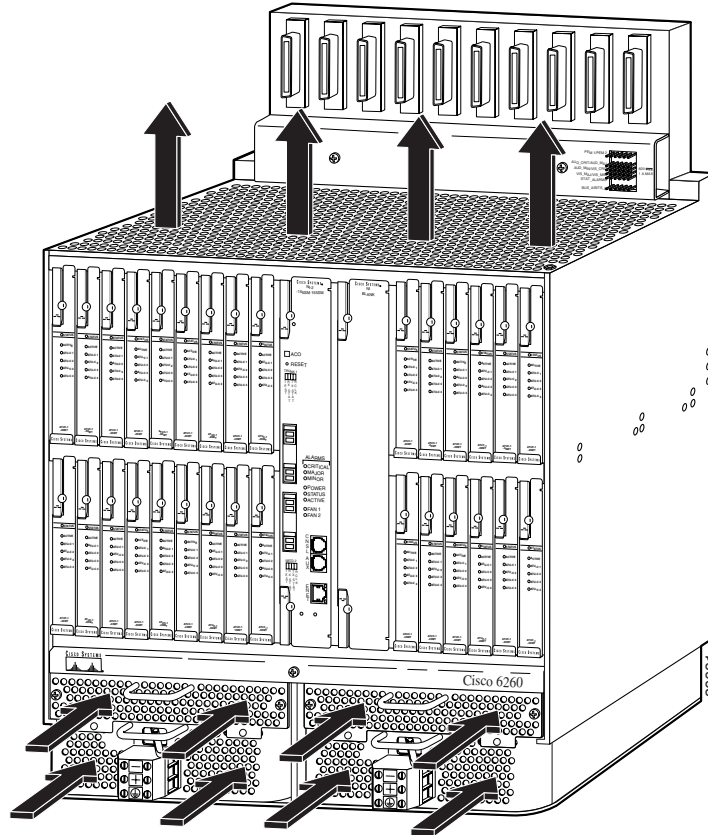

2.2.1.3 Space

The Cisco 6260 system fits in either a 19-inch (48.26 cm) wide rack or a 23-inch (58.42 cm) wide rack, if extenders are installed. See Table 2-2 for individual rack space requirements.

The Cisco 6260 chassis is 23.5 inches (59.69 cm) in height and 10.86 inches (27.58 cm) in depth, taking 13.43 rack units (RUs) of space per chassis. (An RU is equal to 1.75 inches or 4.45 cm.)



Note

Refer to the appropriate vendor documentation for the dimensions of the third-party POTS splitter.

Depending on your configuration type, plan accordingly so that the CO rack accommodates your needs. Use Table 2-2 to calculate the rack space necessary for your Cisco 6260 system configuration.

Table 2-2 Rack Space Calculation for the Cisco 6260 System Configurations

Line	Instructions	Calculation
Cisco 6260 with a POTS Splitter Configuration		
1	Total number of Cisco 6260 chassis in the rack (include subtending host and subtended node chassis).	
2	Total number of POTS splitters ¹ in the rack.	
3	Number of RUs required for the POTS splitter ² .	
4	Multiply 13.43 RUs by the total number of chassis on line 1.	
5	Multiply line 3 by the total number of POTS splitters on line 2.	
6	Add lines 4 and 5 for the total number of RUs needed with your Cisco 6260 with a POTS splitter configuration.	
Cisco 6260 without a POTS Splitter Configuration		
6	Total number of Cisco 6260 chassis in the rack.	
7	Multiply 13.43 RUs by the total number of chassis on line 6 for the total number of RUs needed with your Cisco 6260 without a POTS splitter configuration.	

1. Third-party POTS splitter

2. See the documentation that accompanied the third-party POTS splitter to determine the number of RUs required. One RU is equal to 1.75 inches (4.45 cm).

2.2.2 Power Requirements

The CO power source or rectifier supplies external power to the system as –48V direct current (DC) from the fuse and alarm panel. Power connections from the fuse and alarm panel are wired separately to the Cisco 6260 chassis. Connections for single- and dual-power feeds are provided. The power input connections are redundant, and only one is required for system operation. The nominal voltage is –48 VDC; the minimum operating value is –36 VDC; and the maximum operating value is –60 VDC.



Caution

Before you connect the system to a power source, verify that the power source is properly grounded and that it falls within the internal power supply rating.

The typical power required for your Cisco 6260 system will depend on your configuration type. Use Table 2-3 to calculate the power required for each of the Cisco 6260 system components and the total power required for the system.

Table 2-3 Power Calculation for the Cisco 6260 System

Line	Instructions	Calculation
1	If you are using 4xDMTs, multiply 16.5W by the total number of 4xDMTs installed in the chassis.	
2	If you are using 4xDMT over ISDNs, multiply 16.5W by the total number of 4xDMT over ISDNs installed in the chassis.	

Table 2-3 Power Calculation for the Cisco 6260 System

Line	Instructions	Calculation
3	If you are using 4xflexis, multiply 17.5W by the total number of 4xflexis installed in the chassis.	
4	If you are using 4xSDSLs, multiply 9W by the total number of 4xSDSLs installed in the chassis.	
5	If you are using 8xDMTs, multiply 24W by the total number of 8xDMTs installed in the chassis.	
6	If you are using 8xDMT over ISDNs, multiply 24 W by the total number of 8xDMT over ISDNs installed in the chassis.	
7	If you are using 8xG.SHDSLs, multiply 16.5W by the total number of 8xG.SHDSLs installed in the chassis.	
8	Multiply 33.5W by the number of NI-2 cards installed in the chassis.	
9	Enter 50W for each PEM.	
10	Enter 34.5W for each fan tray.	
11	Add lines 1 through 10. This is the typical power required for the Cisco 6260.	

2.2.3 Rack-Mounting Requirements

We recommend that you mount the Cisco 6260 system in a rack. Ensure that vertical hole spacing on the rack rails meets standard EIA-310-C or ETS300 requirements—1 inch (2.54 cm) spacing.

The Cisco 6260 fits into a 19-inch wide rack, or an ETSI 600-mm-wide (23-inch-wide) rack or cabinet.



Warning

Two people are required to lift the chassis. Grasp the chassis underneath the lower edge and lift with both hands. To prevent injury, keep your back straight and lift with your legs, not your back.



Warning

To prevent bodily injury when mounting or servicing this unit in a rack, you must take special precautions to ensure that the system remains stable. The following guidelines are provided to ensure your safety:

—This unit should be mounted at the bottom of the rack if it is the only unit in the rack.

—When mounting this unit in a partially filled rack, load the rack from the bottom to the top with the heaviest component at the bottom of the rack.

—If the rack is provided with stabilizing devices, install the stabilizers before mounting or servicing the unit in the rack.

2.3 Required Tools and Equipment

Table 2-4 lists the tools and equipment you need to install and connect the Cisco 6260 system components as detailed in Chapter 3, “Installing a Cisco 6260 with a POTS Splitter Configuration,” and Chapter 4, “Installing a Cisco 6260 Without a POTS Splitter Configuration.”

Table 2-4 also lists the tools and equipment you need to remove and install the Cisco 6260 system components as detailed in Chapter 6, “Upgrading and Maintaining the Cisco 6260 System.”

Table 2-4 Tool and Equipment Requirements Checklist

Check	Tools and Equipment
Hardware Components	
	Cisco 6260 chassis
	Line cards (if not already installed in the Cisco 6260 chassis) <ul style="list-style-type: none"> • 4xDMT • 4xDMT over ISDN • 4xflexi • 4xSDSL • 8xDMT • 8xDMT over ISDN • 8xG.SHDSL
	NI-2 card(s) (if not already installed in the Cisco 6260 chassis) <ul style="list-style-type: none"> • DS3/2DS3 • DS3+T1/E1 IMA • OC-3c/OC-3c SMF¹ or MMF²
	I/O module (if not already installed in the Cisco 6260 chassis) <ul style="list-style-type: none"> • E3 • E1 • OC-3c
	Blank faceplates
	Fan trays (if not already installed in the Cisco 6260 chassis)
	PEMs (if not already installed in the Cisco 6260 chassis)
	Champ cables
	Third-party vendor POTS splitter ³
Software Components	
	<ul style="list-style-type: none"> • Cisco IOS • CDM⁴
Tools	
	A 3/16-inch flat-head screwdriver
	A Phillips-head screwdriver

Table 2-4 Tool and Equipment Requirements Checklist (continued)

Check	Tools and Equipment
	Necessary equipment for ESD protection—Required whenever you handle Cisco DSLAM equipment, which includes the chassis and cards
	Mounting screws—To mount the Cisco 6260 to the rack
	Wire-wrapping tool
	Wire stripper
	Wire for connections: <ul style="list-style-type: none"> • 12 american wire gauge (AWG) black and red copper solid or stranded—Used for Cisco 6260 chassis power connections • 10 AWG or thicker green or green with yellow stripes copper stranded—Used for the Cisco 6260 chassis grounding
	Tie wraps (optional)
	Ferrites that yield an impedance of 53 ohms at 25 MHz and 177 ohms at 100 MHz—For connecting the Ethernet to the management network
	Coaxial cable: <ul style="list-style-type: none"> • Type 734A or equivalent • Type 735A or equivalent
	Fiber cable (SMF or MMF)—Used to connect the OC-3c NI-2 card
	RJ-45 serial cable to connect the console and auxiliary connectors
	RJ-45 connector, straight-through 10BaseT/100BaseTX Ethernet, half/full-duplex compliant with IEEE 802.3

1. SMF = single-mode fiber.
2. MMF = multimode fiber.
3. The third-party vendor POTS splitter is used in a Cisco 6260 with a POTS splitter configuration only.
4. CDM = Cisco DSL Manager.

**Note**

The Cisco 6260 system has no internal user-serviceable parts.

**Warning**

Only trained and qualified personnel should be allowed to install, replace, or service this equipment.

2.4 Unpacking the Cisco 6260 System

Each Cisco 6260 system chassis is securely packaged in a shipping box. The Cisco 6260 system components ship with the line cards and NI-2 card(s) installed in the chassis.

**Caution**

Proper ESD protection is required whenever you handle Cisco DSLAM equipment. Installation and maintenance personnel should be properly grounded using ground straps to eliminate the risk of ESD damage to the equipment. Cards are subject to ESD damage whenever they are removed from the chassis.

To unpack the Cisco 6260 system, complete the following steps:

Step 1 Inspect the packing containers.

If any damage or other signs of mishandling are evident, inform both the local freight carrier and Cisco before unpacking. Your freight carrier can provide you with the procedures necessary to file a claim for damages.

Step 2 Carefully open the box.

Step 3 Remove all packing material.

Step 4 Remove the chassis from the box.

**Warning**

Two people are required to lift the chassis. Grasp the chassis underneath the lower edge and lift with both hands. To prevent injury, keep your back straight and lift with your legs, not your back.

Step 5 Carefully open the additional boxes, remove the packing material, and remove the contents.

Step 6 Open the accessory kits and boxes that contain the cables, ferrites, and management software. Do not use a knife to open these boxes.

2.5 Verifying Contents

To verify that your shipment is complete, make sure that you received everything on your packing list, and then compare your packing list to your order. If any items are missing or you need additional information, contact the Cisco Technical Assistance Center (TAC) at one of the following:

- 800 553-2447
- 408 526-7209
- tac@cisco.com

2.6 Inspecting for Damage

After you verify that all of the equipment is included, carefully examine the assemblies, cards, and cables for any damage resulting from shipping. If you suspect any damage from shipping, contact your local freight carrier for procedures on damage claims.

If you observe any physical defects in the items you ordered, obtain standard warranty service by delivering the defective part, accompanied by a copy of the dated proof-of-purchase, to the Cisco Systems Corporate Service Center or an Authorized Cisco Systems Service Center during the applicable warranty period. Contact the Cisco TAC for the location of your nearest service center.

See the back of the title page for Cisco Systems supplementary warranty information for hardware and software products.



Installing a Cisco 6260 with a POTS Splitter Configuration

This chapter provides installation procedures for a Cisco 6260 with a POTS splitter configuration.



Note

The installation procedures in this chapter apply to a Cisco 6260 system shipped with the individual hardware components already installed. For information about installing or replacing hardware components in the Cisco 6260 chassis, see Chapter 6, “Upgrading and Maintaining the Cisco 6260 System.”



Warning

Only trained and qualified personnel should be allowed to install, replace, or service this equipment.



Caution

Before you begin the installation procedures, read the entire chapter for important information and safety warnings.



Note

Before installing and cabling the equipment, be aware of standard safety practices and the hazards involved in working with electrical circuitry to prevent accidents. See the “Safety Requirements” section on page 2-1 for cautions and warnings that are necessary to ensure a safe and hazard-free installation.

To see translations of the warnings that appear in this publication, refer to the *Regulatory Compliance and Safety Information for the Cisco 6260 System* document.



Tip

See the “Cisco 6260 System with a POTS Splitter Configuration” section on page 1-4 for more information about Cisco 6260 with a POTS splitter configuration components.

3.1 Installation Checklist

When you install a Cisco 6260 with a POTS splitter configuration, be sure that you follow the installation procedures in the proper sequence. Table 3-1 is a checklist of the installation steps in the order in which they should occur. Detailed installation instructions are located in the sections following Table 3-1.



Caution

Proper ESD protection is required whenever you handle Cisco equipment. Installation and maintenance personnel should be properly grounded using ground straps to eliminate the risk of ESD damage to the equipment. Cards are subject to ESD damage whenever they are removed from the chassis.

Table 3-1 *Installation Checklist—Cisco 6260 with a POTS Splitter Configuration*

Check	Installation Procedure
	1. Measure the rack space.
	2. Install the third-party POTS splitter(s) in the rack.
	3. Attach Cisco 6260 ear brackets.
	4. Install the Cisco 6260 chassis in the rack.
	5. Install blank faceplates.
	6. Ground the Cisco 6260.
	7. Ground the third-party POTS splitter.
	8. Connect the Cisco 6260 chassis to the third-party POTS splitter.
	9. Connect the third-party POTS splitter to the MDF ¹ or to the cross connect, as necessary.
	10. Attach the Cisco 6260 power connections.
	11. Connect the alarm and BITS clock contacts (optional).
	12. Apply power to the system.
	13. Verify that the fan trays are operational.
	14. Connect the Cisco 6260 to the network.
	15. Install a subtended network configuration (optional).
	16. Connect the Ethernet to the management network.
	17. Connect a console terminal.
	18. Connect the auxiliary port (optional).
	19. Complete the initial configuration.

1. MDF = main distribution frame

3.2 Installation Procedures

The following sections detail the installation procedures for a Cisco 6260 with a POTS splitter configuration.

3.2.1 Measure Rack Space

For the rack to remain stable, you must install your Cisco 6260 system from the bottom to the top of the rack.

Before you install any of the chassis, measure the total rack space required to install your system. The required rack space depends on the number of Cisco 6260 chassis and third-party POTS splitters that you plan to use. The number of chassis increases if you plan to install a subtended network.

**Note**

See Chapter 2, “Preparing for Installation,” to determine the total rack space you need for your configuration.

**Warning**

To prevent bodily injury when mounting or servicing this unit in a rack, you must take special precautions to ensure that the system remains stable. The following guidelines are provided to ensure your safety:

—This unit should be mounted at the bottom of the rack if it is the only unit in the rack.

—When mounting this unit in a partially filled rack, load the rack from the bottom to the top with the heaviest component at the bottom of the rack.

—If the rack is provided with stabilizing devices, install the stabilizers before mounting or servicing the unit in the rack.

**Warning**

Two people are required to lift the chassis. Grasp the chassis underneath the lower edge and lift with both hands. To prevent injury, keep your back straight and lift with your legs, not your back.

**Warning**

Never attempt to lift the chassis with the handles on the power supplies, fan trays, or the switching modules. These handles are not designed to support the weight of the chassis. Using them to lift or support the chassis can result in severe damage to the equipment and serious bodily injury.

If you plan to expand your system to include more chassis in the future, allow space in the rack for additions, keeping in mind the weight distribution and stability of the rack.

3.2.2 Install the Third-Party POTS Splitter

The third-party POTS splitter is installed directly below the Cisco 6260 chassis in the rack.

Refer to the appropriate vendor documentation for installation procedures for the third-party POTS splitter.

3.2.3 Attach Ear Brackets to the Cisco 6260

Verify that the ear brackets on the sides of the chassis are in the proper configuration to fit the rack, and if necessary, reinstall them. Ear brackets can be installed in two ways, as shown in Figure 3-1:

Figure 3-1 Mounting Options for Ear Brackets

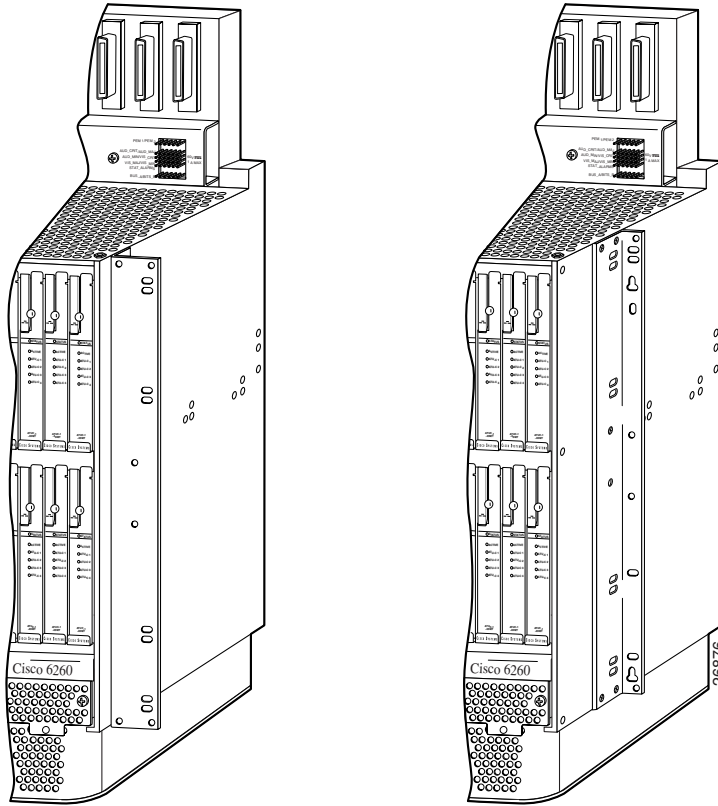

Bracket orientation for
ETS 600-mm rack

Bracket orientation
for 19-inch rack

For Cisco 6260 installation in an ETSI 600-mm (23-inch) rack, attach the L-shaped ear brackets so that the short sides are against the chassis wall and the long sides protrude from the chassis.

For Cisco 6260 installation in a 19-inch rack, attach the ear brackets so that the long side of each L is against the chassis wall and the short side protrudes from the chassis.



Note

The ear brackets are installed in the factory for a 19-inch rack configuration.

3.2.4 Install the Cisco 6260 Chassis

Complete the following steps to install the Cisco 6260 chassis.



Warning

Two people are required to lift the chassis. Grasp the chassis underneath the lower edge and lift with both hands. To prevent injury, keep your back straight and lift with your legs, not your back.

- Step 1** Connect a grounding strap to the ESD grounding jack that is located on the top right of the front of the Cisco 6260 chassis.
- Step 2** Using a Phillips-head screwdriver, attach the two mounting aids to the rack above the third-party POTS splitter. Use two screws for each mounting aid, as shown in Figure 3-2. The lower edge of the mounting aid lines up with the bottom of the chassis.

Figure 3-2 Screw the Mounting Aids to the Rack

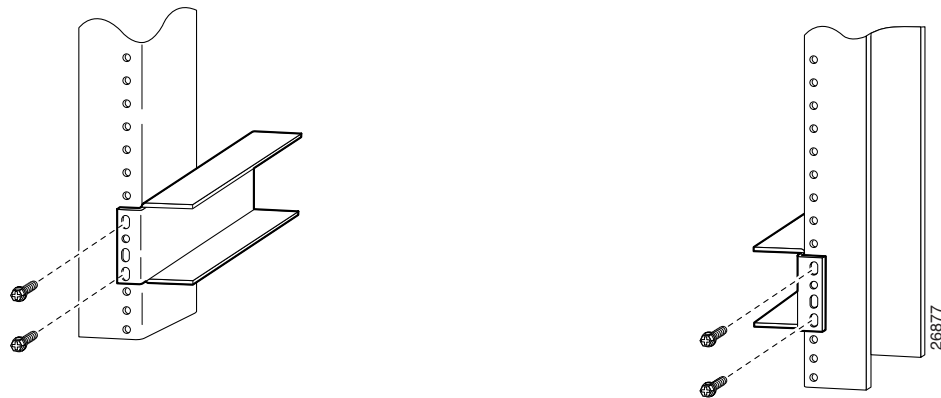

Step 3 Carefully lift the chassis from underneath and rest it on the mounting aids, as shown in Figure 3-3.

Figure 3-3 Mounting Aids Support the Chassis During Installation

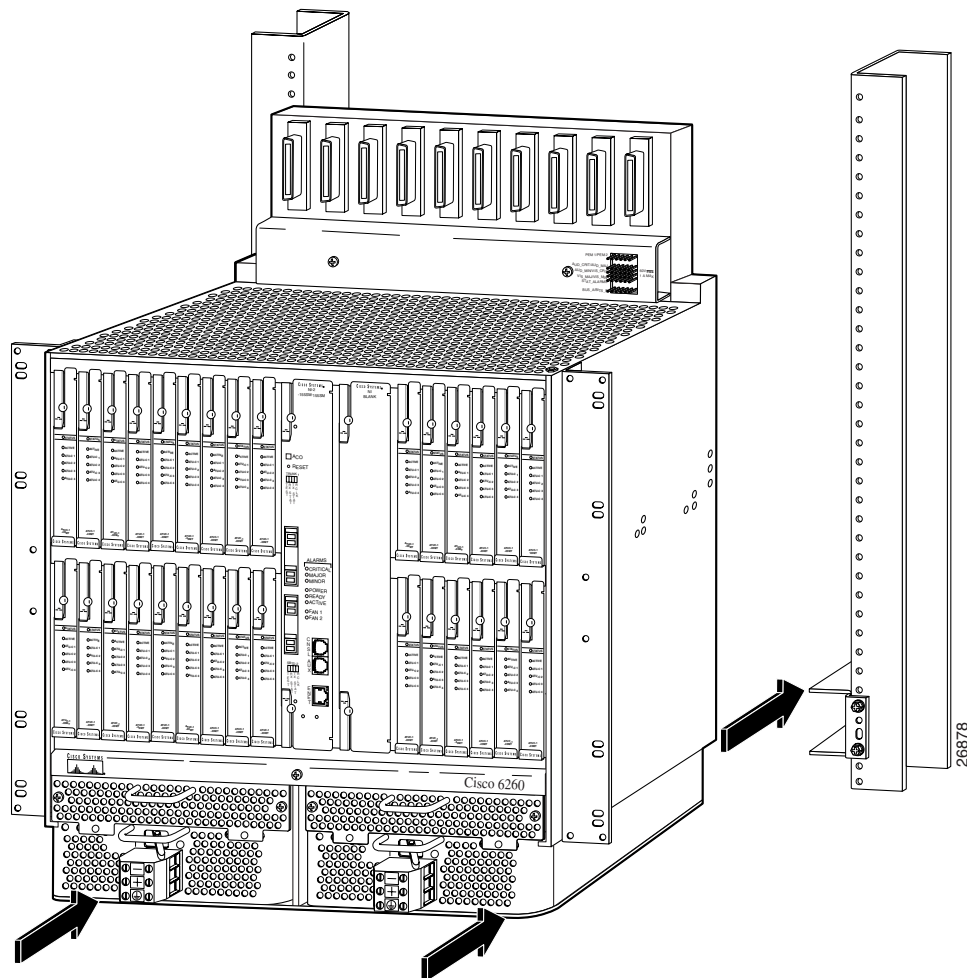

Step 4 Push the chassis back into the rack.

Step 5 Using a Phillips-head screwdriver, screw the ear brackets on the chassis to the rack. Use two screws at the top of each ear bracket and two at the bottom (four screws per bracket). For stability, make sure you use at least one round hole at each end of each bracket (the ear brackets have both round and oval holes).

Step 6 Repeat Step 1 through Step 5 for each Cisco 6260 chassis that you are installing.

3.2.5 Install Blank Faceplates

Blank faceplates should occupy any empty slots in the Cisco 6260 chassis. Blank faceplate installation is similar to line card installation.

Complete the following steps to install blank faceplates in the Cisco 6260:

-
- Step 1** Connect a grounding strap to the ESD grounding jack that is located on the top right of the front of the Cisco 6260 chassis.
 - Step 2** Vertically align the blank faceplate edge with the guides at the top and bottom of the slot.
 - Step 3** Lift up on the ejector tab and gently apply pressure to the bottom of the faceplate while pushing the blank faceplate into the slot.
 - Step 4** Push on the faceplate to fully seat the blank faceplate.
 - Step 5** Press down on the ejector tab to secure the faceplate.
-

3.2.6 Ground the Cisco 6260

Complete the following steps to connect the grounding lug on the Cisco 6260.



Warning

When you are installing the unit, the ground connection must always be made first and disconnected last.



Warning

Before connecting or disconnecting ground or power wires to the chassis, ensure that power is removed from the DC circuit. To ensure that all power is OFF, locate the circuit breaker on the panel board that services the DC circuit, switch the circuit breaker to the OFF position, and tape the switch handle of the circuit breaker in the OFF position. Use a voltmeter to test for 0 (zero) voltage at the power terminals on the chassis.

-
- Step 1** Ensure that power in the direct current (DC) circuit is off.
 - Step 2** Remove all paint or oxidation from the rack at the point of the grounding connection.
 - Step 3** Measure enough wire to connect the Cisco 6260 to the rack. Use 10 American Wire Gauge (AWG) green or green with yellow stripes wire to ground the Cisco 6260 chassis.



Note Use only as much wire as is necessary to make the connection.

- Step 4** Use a wire stripping tool to remove the covering from the end of the grounding wire. The manufacturer of the grounding lug might have a specific recommendation about the length of wire to be stripped.
- Step 5** Insert the stripped end of the grounding wire into the open end of the grounding lug. Be careful not to leave any wire strands outside the lug.
- Step 6** Use the crimping tool to compress the lug onto the wire.
- Step 7** To verify the quality of the crimp, inspect it and tug gently on the wire.
- Step 8** Locate the three grounding holes on the Cisco 6260 side panel. (See Figure 3-4.)
- Step 9** Match the holes in the grounding lug to the appropriately spaced pair of grounding holes on the side of the chassis. Use the top two holes for a 5/8-inch lug, as shown in Figure 3-4. Use the bottom two holes for a 3/4-inch lug.

Figure 3-4 System Ground Connection

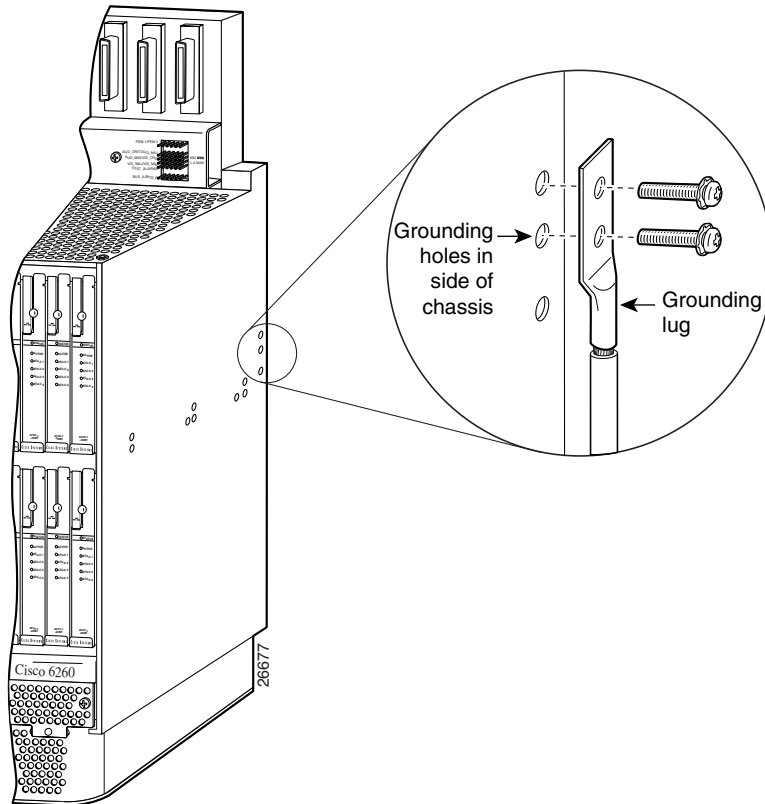

- Step 10** Insert the screws through the holes in the lug and the chassis. Use the Phillips-head screwdriver to tighten the screws and secure the grounding lug firmly to the chassis.
- Step 11** Prepare the other end of the grounding wire and connect it to an appropriate grounding point in your site.
- Step 12** Repeat Step 1 through Step 11 for each Cisco 6260 chassis, as necessary.

3.2.7 Ground the Third-Party POTS Splitter

Refer to the appropriate vendor documentation for grounding procedures for the third-party POTS splitter.



Note

Do not ground the components in a rack by chaining them together.

3.2.8 Connect the Cisco 6260 to the Third-Party POTS Splitter

Refer to the appropriate vendor documentation for cabling procedures for the third-party POTS splitter.

3.2.9 Connect the Third-Party POTS Splitter to the MDF or to the Cross Connect

Refer to the appropriate vendor documentation for procedures for connecting the POTS splitter to the MDF or to the cross connect.

3.2.10 Attach Cisco 6260 Power Connections

External power is supplied to the system as –48 VDC from the central office (CO) power source or rectifier to the fuse and alarm panel. Power is fed from the fuse and alarm panel to receptacles in terminal blocks located on the power entry modules (PEMs) installed in the Cisco 6260 chassis.

Connect the power connections on each PEM to separate power sources to achieve full power redundancy. If you do not require power redundancy, use the terminals on a single PEM, or connect both PEMs to a single power source.

Complete these instructions to connect the Cisco 6260 system to a –48 VDC power source. Ground the chassis before you attempt this procedure, as described in the “Ground the Cisco 6260” section on page 3-7.



Note

See Chapter 2, “Preparing for Installation,” for the calculation tables that you need to determine the minimum power requirements for your system.



Caution

To prevent the system from powering up, do not install the fuses at this time. If the fuses are already installed in the fuse and alarm panel, remove them. You can replace the fuses after the system is installed and connected.

Follow these instructions to attach the power connections to the Cisco 6260 PEM:

Step 1

Verify that power in the DC circuit is off.



Warning

Before connecting or disconnecting ground or power wires to the chassis, ensure that power is removed from the DC circuit. To ensure that all power is OFF, locate the circuit breaker on the panel board that services the DC circuit, switch the circuit breaker to the OFF (0) position, and tape the switch handle of the circuit breaker in the OFF (0) position. Use a voltmeter to test for 0 (zero) voltage at the power terminals on the chassis.

Step 2

Connect a grounding strap to the ESD grounding jack that is located on the top right of the front of the Cisco 6260 chassis.

Step 3

Prepare the wire for the Cisco 6260 power and grounding connections, as follows:

- a. Measure enough wire (6 to 10 AWG multistranded copper wire) to connect each of the PEM power connections to the fuse and alarm panel, as well as enough to connect the grounding receptacle on the PEM terminal block to the grounding connection at the DC power source.

- b. Cut the ends of the power and ground wires so that the ends are straight, not slanted.
- c. Measure 0.43 inch (11 mm) up from the end of each power and ground wire and place a mark at that point. These are the wire ends that will be connected to the Cisco 6260.
- d. Use the wire stripping tool to remove 0.43 inch (11 mm) of the covering from both ends of each wire. Trim the ends of the covering so that they are straight, as shown in Figure 3-5, not slanted.

Figure 3-5 Strip and Square Off Power and Ground Wires

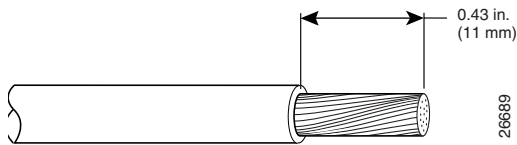

Warning

Remove the covering from exactly the specified length of each power wire. If you strip too much of the covering, exposed wire protruding from the terminal block will create an electrical hazard. If you strip too little of the covering, the wire may not make a good contact with the terminal, or it may not be held securely in place in the terminal block.

- Step 4** Use a flat-head screwdriver to turn all three screws on the terminal block counterclockwise to open the terminal connectors: + (positive), – (negative), and ground. This step ensures that the correct opening is presented for the wires, as shown in Figure 3-6.

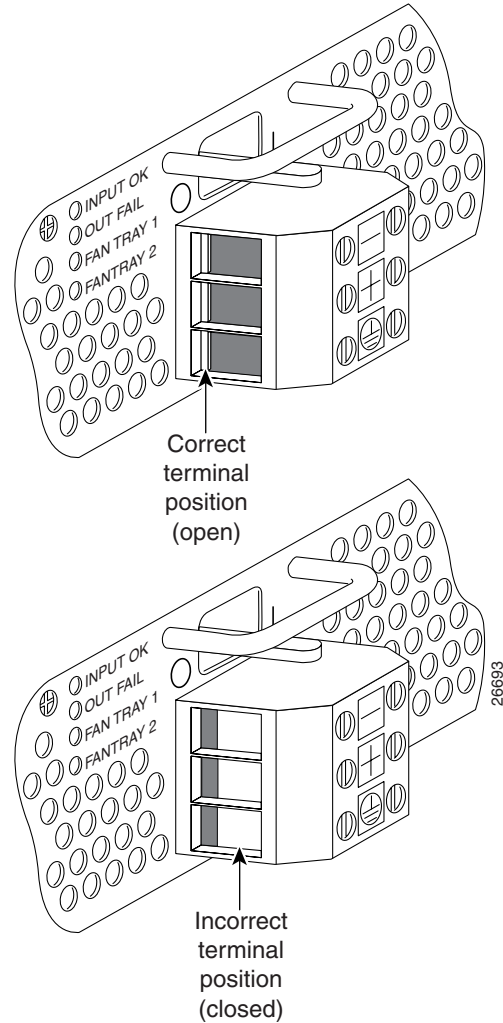
Figure 3-6 Positioning the Power and Ground Terminals to Accept Wires

- Step 5** Insert the end of the grounding wire into the grounding receptacle, which is the bottom receptacle in the terminal block on the PEM (see Figure 3-7). The stripped part of the wire must be fully inserted into the terminal block so that no bare wire is exposed.
- Step 6** Ensure that no wire strands are left outside the connector.

- Step 7** Using the screwdriver and a clockwise motion, tighten the ground screw in the terminal block. Gently tug on the wire to ensure that it is firmly in place.

Figure 3-7 Insert Grounding Wire into Grounding Receptacle

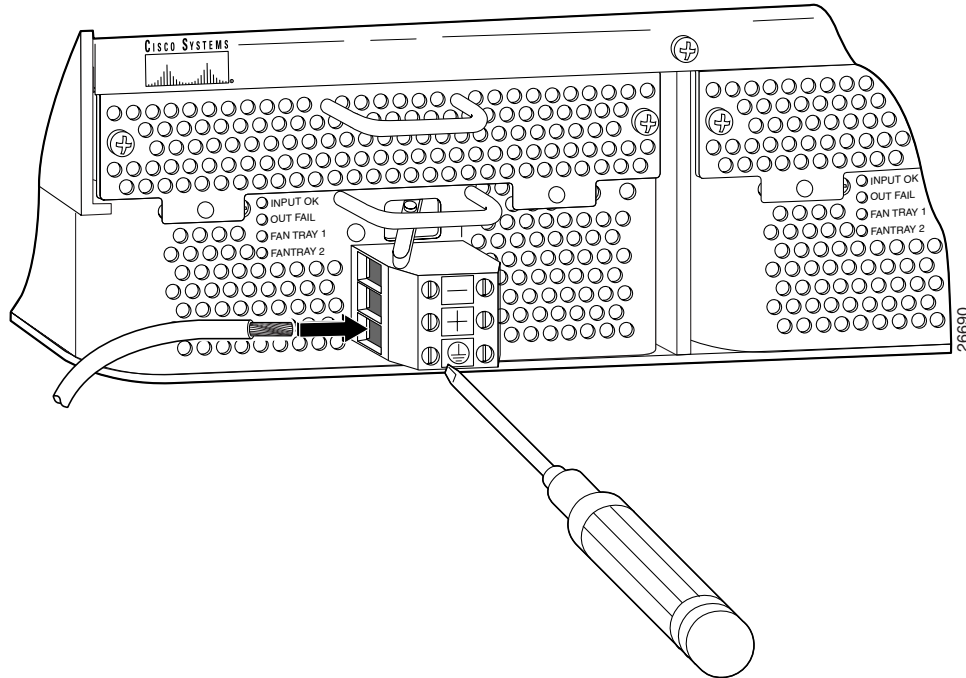

- Step 8** Make sure that the other end of the grounding wire is connected to ground at the DC power source.
- Step 9** If you are connecting two power sources to the Cisco 6260 system, repeat Step 2 through Step 8 for the second PEM.



Warning

Only a DC power source that is isolated from the AC main power source with reinforced insulation, and that complies with the other safety extra-low voltage (SELV) requirements in UL1950, CSA 950 3rd Edition, EN 60950, and IEC950, can be connected to a Cisco 6260 system. This requirement ensures that in a catastrophic power source fault condition, hazardous voltages are not present on power terminals and connectors.

- Step 10** After connecting the battery return wire to the external power source, insert the other end into the receptacle labeled + (positive) on the terminal block of the first PEM, as shown in Figure 3-8. The stripped part of the wire must be fully inserted so that no bare wire is exposed. Using the screwdriver and a clockwise motion, tighten the terminal screw. Gently tug on the wire to ensure that it is firmly in place.

Figure 3-8 Connecting Power to the Terminal Block

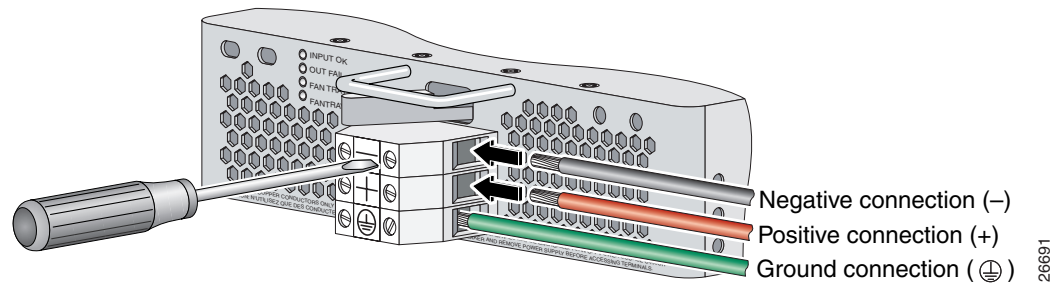

- Step 11** After connecting the power lead to the external –48V power source, insert the other end of the wire into the receptacle labeled – (negative) on the terminal block of the first PEM, as shown in Figure 3-8. The stripped part of the wire must be fully inserted so that no bare wire is exposed. Using the screwdriver and a clockwise motion, tighten the terminal screw. Gently tug on the wire to ensure that it is firmly in place.
- Step 12** If you are connecting a second power source, repeat Step 10 and Step 11 to wire it to the second PEM.



Note Be sure that the chassis is connected to earth ground as described in the “Ground the Cisco 6260” section on page 3-7. The Cisco 6260 requires two or three ground connections, one to the side of the chassis and one to each PEM.

- Step 13** Repeat Step 2 through Step 12 for each Cisco 6260 chassis, as necessary.



Warning Do not yet power up the system.

3.2.11 Connect the Alarm and BITS Clock Contacts



Note Connecting the alarm and BITS clock contacts are optional procedures.

Complete the following steps to connect the external alarm and BITS clock contacts:

- Step 1** Connect the external alarm device and BITS clock to the wire-wrap pins on the I/O module at the top of the chassis.
- a. Measure one strand of twisted-pair wire (24 AWG industry standard T1/E1 cable) long enough to connect to the appropriate pin.

See Figure 3-9 for a close-up of the pinouts that are located on the I/O module. For pinout descriptions, see the “E1 I/O Module RJ-48c Connectors” section on page C-2.

Figure 3-9 I/O Module Wire-Wrap Pins Close-up

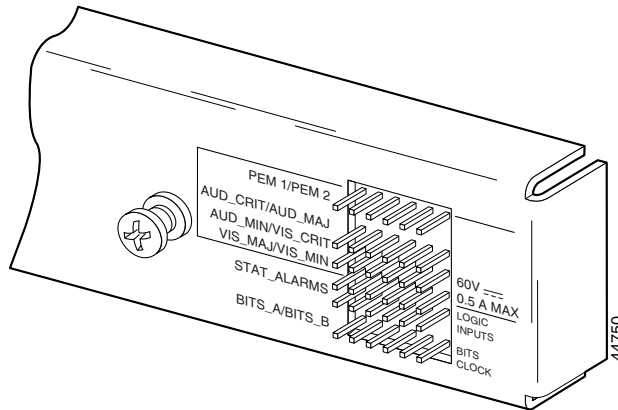

- b. Use a wire stripper to remove the casing from both ends of the wire.
- c. Use a wire-wrapping tool to attach the wire to the appropriate pin.
- d. Use a wire-wrapping tool to attach the other end of the wire that is used in Step 1c to either the BITS clock source or alarm relay contact.
- e. Repeat this step to wire-wrap all the necessary pins.



Note The BITS pins on Cisco 6260 I/O cards are slot specific. BITS_A pins are assigned to chassis slot 11 and BITS_B pins are assigned to chassis slot 10. Each BITS clock input is independent and terminated at 100 ohms.

- Step 2** Reboot the system to reassociate the system MAC address.
- Step 3** Repeat Step 1 and Step 2 for each Cisco 6260 chassis, as necessary.

3.2.12 Apply Power

Complete the following steps to apply power to the Cisco 6260 system:

- Step 1** Apply power to the system with one of the following methods:
 - Install the fuses in the fuse and alarm panel.
 - Reinsert the fuses in the fuse and alarm panel, if you removed them in the “Attach Cisco 6260 Power Connections” section on page 3-9.
 - Turn on the breakers in the fuse and alarm panel.



Caution

If the power connections are improperly made and power is applied while the cards are installed, the cards and chassis could be damaged.

- Step 2** Verify that the power connections are made correctly, as described in the “Attach Cisco 6260 Power Connections” section on page 3-9.
- Step 3** Check the polarity of the –48 VDC connections to each chassis by attaching a voltmeter with the minus lead on –48RTN and the plus lead on –48V_A or –48V_B. Ensure that the meter reads between –40.5 VDC and –75 VDC. If your voltmeter shows a positive voltage, check to ensure that the meter leads are not reversed. If the voltmeter shows a negative voltage that is out of the –40.5 VDC to –75 VDC range, check the power supply for failure or check for a blown fuse in the fuse and alarm panel.
- Step 4** Turn on power to the DC circuit.
- Step 5** Use a voltmeter to check the voltage at the terminal block. Connect the voltmeter positive contact to the positive (+) terminal on the Cisco 6260 terminal block. Connect the voltmeter negative contact to the negative (–) terminal on the Cisco 6260 terminal block. If the power is wired correctly, you will see a reading of –48V on the voltmeter.
- Step 6** At the front of the chassis, switch the circuit breakers on both PEMs to the ON (1) position.
- Step 7** Repeat Step 1 through Step 6 for each Cisco 6260 chassis, as necessary.
-

3.2.13 Verify Fan Tray Operation

Verify that the fan trays are operational by checking the fan tray LEDs, located on the PEMs that are installed beneath the fan trays. If the LED is

- Green—The fan is operational.
- Not green—The fan is not operational and the fan tray may be in alarm mode. See Chapter 5, “Troubleshooting,” for corrective action.



Caution

The fans in both fan trays must run continuously. The system might suffer thermal damage if the fans in either tray stop for more than 5 minutes.

3.2.14 Connect the Cisco 6260 System to the Network

The following sections provide instructions for making E3, E1, and OC-3c network connections from the Cisco 6260 system.

3.2.14.1 E3 Network Connection

The E3 network connection is made from E3 I/O module. Complete the following steps to connect the E3 I/O module to the network.



Tip

We recommend that you label each data cable at both ends to identify its destination.

- Step 1** Verify that you have both a DS3/2DS3 NI-2 card and an E3 I/O module installed in the Cisco 6260 chassis.

The E3 I/O module connections marked P1 attach to the ATM switch. Two 75-ohm Bayonet-Neill-Concelman (BNC) connectors for E3 transmit (TX) and receive (RX) are provided. See Figure 3-10 for the location of the P1 BNC connectors.

Figure 3-10 E3 I/O Module BNC Connectors

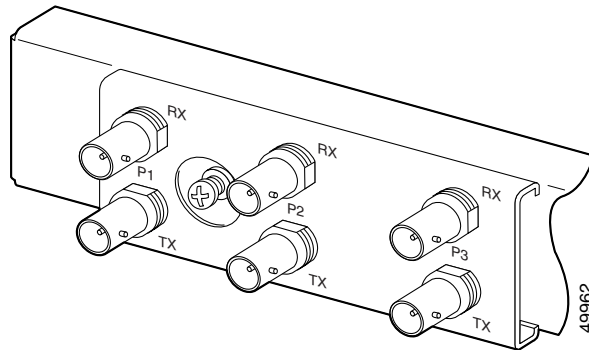

- Step 2** Attach one end of a coaxial cable (type 734A or equivalent) to the P1 TX BNC connector on the E3 I/O module.



Note See Table 2-4 on page 2-16 for cable requirements.

- Step 3** Attach the other end of the cable to the ATM switch.
- Step 4** Attach one end of a coaxial cable (type 734A or equivalent) to the P1 RX BNC connector on the E3 I/O module.
- Step 5** Attach the other end of the cable to the ATM switch.
- Step 6** Repeat Step 1 through Step 5 for each Cisco 6260 chassis, as necessary.

3.2.14.2 E1 Network Connection

The E1 network connection is made from E1 I/O module. Complete the following steps to connect the E1 I/O module to the network:

- Step 1** Verify that you have both a DS3+T1/E1 IMA NI-2 card and an E1 I/O module installed in the Cisco 6260 chassis.

The E1 I/O module connections attach to the ATM switch. Cisco provides four sets of two vertically paired E1 RJ-48c (120-ohm) connectors that can be used as network trunk connections, individual E1 subtend links, connections to IMA subtending groups, or connections to IMA group trunk interfaces. See Figure 3-11 for the location of the E1 RJ-48 receptacle connectors.

Figure 3-11 E1 I/O Module BNC Connectors

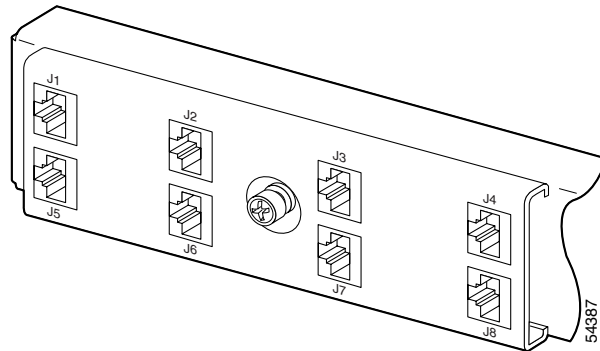

- Step 2** Connect one end of an RJ-45 cable to one of the RJ-48 receptacle connectors on the E1 I/O module. If you have a subtended network configuration installed, this connection must be made to the E1 I/O module in the subtending host chassis.



Note If unshielded cable is used for FCC Class B or EN55022 Class B compliance, the cables must be looped through ferrites.

See Table 2-4 on page 2-16 for cable requirements.

- Step 3** Connect the other end of the cable used in Step 2 to the ATM switch.



Note Verify that the pinouts of the RJ-45 cable connect transmit to receive and receive to transmit.

- Step 4** Repeat Step 1 through Step 3 for each Cisco 6260 chassis, as necessary.



Note Use the procedures in this section to make IMA network connections. See the “IMA Configuration” section on page 1-4 for more information on IMA network connections.

3.2.14.3 OC-3c Network Connection

OC-3c network connections are made from the OC-3c/OC-3c NI-2 card. Complete the following steps to connect the OC-3c/OC-3c NI-2 card to the network.



Warning

Do not stare into the beam or view it directly with optical instruments.

- Step 1** Verify that an OC-3c/OC-3c NI-2 card is in slot 10 of the Cisco 6260 chassis (or slot 11, if you are installing a secondary card for NI-2 redundancy).

- Step 2** Attach the receive (RX) cable from the ATM switch to the trunk 1 (TRNK 1) transmit (TX) connector in the inset on the NI-2 card faceplate. The TX connector is the one closer to the top of the faceplate. The connector IDs are silkscreened inside the inset. See Figure 1-18 for the location of OC-3c network interface connectors.
- Step 3** Attach the TX cable from the ATM switch to the TRNK 1 RX connector in the inset on the NI-2 card faceplate. The RX connector is closer to the bottom of the faceplate. See Figure 1-18 for the location of OC-3c network interface connectors.
- Step 4** Repeat Step 1 through Step 3 for each Cisco 6260 chassis, as necessary.

3.2.15 Install a Subtended Network Configuration

If you are installing a subtended network configuration, complete the steps in the following sections, which provide installation procedures for E3, E1, and OC-3c subtended network configurations.

If you are not installing a subtended network, proceed to the “Connect the Ethernet to the Management Network” section on page 3-20.



Note

For overview information on a subtended network configuration, see the “Subtended Network Configuration” section on page 1-6.

3.2.15.1 Connect the E3 Subtending Network Configuration

Coaxial connections for E3 subtending cabling are located on the I/O module. The P1 TX and RX BNC connectors are reserved for network trunk cabling, or for upstream cabling from a subtended node chassis to the host. The P2 or P3 TX and RX BNC connectors on the subtending host chassis I/O module are connected to the P1 TX and RX BNC connectors on the subtended node chassis I/O module.

Figure 3-12 shows the three sets of BNC connectors and their location on the E3 I/O module.

Figure 3-12 E3 I/O Module BNC Connectors

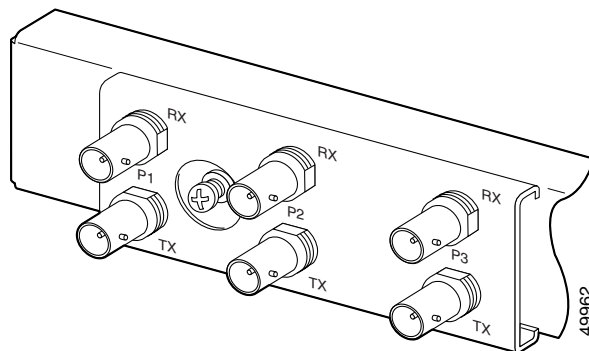

Complete the following steps to cable the E3 I/O module for subtending:

- Step 1** On the subtending host chassis I/O module, attach one end of a BNC cable to the P2 (or P3) TX BNC connector.

- Step 2** On the first subtended node chassis I/O module, attach the other end of the cable to the P1 RX BNC connector.
- Step 3** On the subtending host chassis I/O module, attach one end of a BNC cable to the P2 or (P3) RX BNC connector.
- Step 4** On the first subtended node chassis I/O module, attach the other end of the cable to the P1 TX BNC connector.
- Step 5** Repeat Step 1 through Step 4 to connect the subtending host chassis to each subtended node chassis.

See Figure 1-3 for an illustration of an E3 subtending network configuration.

3.2.15.2 Connect the E1 Subtending Network Configuration

Connections for E1 subtending cabling are located on the I/O module. The RJ-48 E1 connectors on the subtending host chassis I/O module are connected to the RJ-48 E1 connectors on the subtended node chassis I/O module.

Figure 3-13 shows the eight RJ-48 E1 connectors and their location on the E1 I/O module.

Figure 3-13 E1 I/O Module RJ-48 Connectors

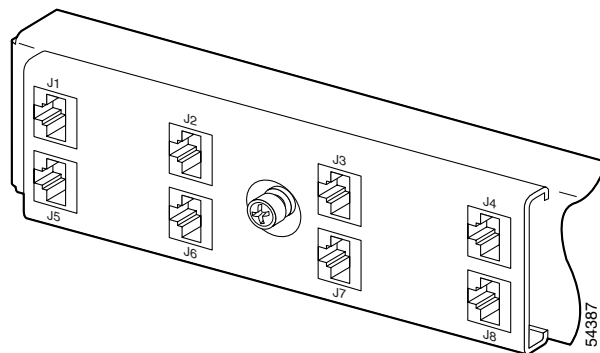

Complete the following steps to cable the I/O module for E1 subtending:

- Step 1** Connect one end of an RJ-45 crossover cable to one of the RJ-48 receptacle connectors on the subtending host chassis E1 I/O module.
- Step 2** Connect the other end of the cable to one of the RJ-48 receptacle connectors on the subtended node chassis E1 I/O module.
- Step 3** Repeat Step 1 and Step 2 to connect the subtending host chassis to each subtended node chassis.



Note If you are using an E1 trunk to the network, the trunk connection originates at one of the RJ-48 receptacle connectors on the E1 I/O module. Therefore, you can have only seven subtended node chassis.

See Figure 1-4 for an illustration of an E1 subtending network configuration.

3.2.15.3 Connect the OC-3c Subtending Network Configuration

Connections for OC-3c subtending are made from the faceplate of the OC-3c/OC-3c NI-2 card installed in the subtending host chassis to the faceplate of the OC-3c/OC-3c NI-2 card installed in the subtended node chassis. See Figure 1-18 for the location of the OC-3c subtending connectors on the faceplate of the NI-2 card.

To cable the Cisco 6260 system for OC-3c subtending, complete the following steps:

-
- Step 1** Locate the TRNK 1 network interface connectors (TX and RX) and the subtend (SBTD) 2 interface connectors (TX and RX) on the front of each OC-3c/OC-3c NI-2 card.
 - Step 2** Attach an OC-3c fiber-optic cable to the SBTD 2 TX interface connector on the NI-2 card installed in the subtending host chassis.
 - Step 3** Attach the other end of the cable to the TRNK 1 RX interface connector on the NI-2 card installed in the subtended node chassis.
 - Step 4** Attach an OC-3c fiber-optic cable to the SBTD 2 RX interface connector on the NI-2 card installed in the subtending host chassis.
 - Step 5** Attach the other end of the cable to the TRNK 1 TX interface connector on the NI-2 card installed in the subtended node chassis.
 - Step 6** To cable your system for APS link redundancy, repeat Step 1 through Step 5 for the secondary NI-2 cards installed in slot 11 of each host and subtending chassis.
-

See Figure 1-5 for an illustration of an OC-3c subtending network configuration.

3.2.16 Connect the Ethernet to the Management Network



Warning

The ports labeled "ENET," "CNLSL," and "AUX" are safety extra-low voltage (SELV) circuits. SELV circuits should be connected only to other SELV circuits. Because the DSL circuits are treated like telephone-network voltage, avoid connecting the SELV circuit to the telephone network voltage (TNV) circuits.



Timesaver

We recommend that you label each data cable at both ends to identify its destination.

Complete the following steps to connect the Ethernet to the management network:

-
- Step 1** Connect the Ethernet cable to the NI-2 card ENET receptacle (see Figure 1-18 for the location of the ENET receptacle on the faceplate of the NI-2 card).



Note

See Table 2-4 on page 2-16 for cable and ferrite requirements.

- Step 2** Run the cable through the ferrite one time, loop the cable back through the ferrite, and clamp the ferrite shut.
- Step 3** Connect the other end of the cable to the management network (for example, a LAN).

3.2.17 Connect a Console Terminal

Connect a VT100-compatible terminal to the NI-2 card CNSL receptacle (see Figure 1-18 for the location of the CNSL receptacle on the faceplate of the NI-2 card). Connect the terminal to a power source and set it up using the values shown in Table 3-2.



Warning

The ports labeled "ENET," "CNSL," and "AUX" are SELV circuits. SELV circuits should be connected only to other SELV circuits. Because the DSL circuits are treated like telephone-network voltage, avoid connecting the SELV circuit to the TNV circuits.

Table 3-2 Terminal Settings

Baud rate	9600 to 38,400 bps (transmit and receive)
Character size	8 bits
Parity	None
Stop bits	1
Flow control	None

3.2.18 Connect the Auxiliary Port

Connect a terminal, a modem, or another serial device to the NI-2 card RJ-45 AUX receptacle (see Figure 1-18 for the location of the AUX receptacle on the faceplate of the NI-2 card).



Note

This action is optional.



Warning

The ports labeled "ENET," "CNSL," and "AUX" are SELV circuits. SELV circuits should be connected only to other SELV circuits. Because the DSL circuits are treated like telephone-network voltage, avoid connecting the SELV circuit to the TNV circuits.



Timesaver

We recommend that you label each data cable at both ends to identify its destination.

3.2.19 Complete Initial Configuration

When you turn on the Cisco 6260 for the first time, an interactive dialog called the System Configuration Dialog appears in a window on the console screen. The System Configuration Dialog guides you through the initial configuration process. (You can run the dialog at any time by entering the **setup** command in privileged EXEC mode.)

When you complete the dialog, the system displays the configuration command script that you have created. It then offers you three options:

```
[0] Go to the IOS command prompt without saving this config.
[1] Return back to the setup without saving this config.
[2] Save this configuration to nvram and exit.
```

If you enter **2**, the configuration is saved and used. If you answer **0** or **1**, the configuration you created is not saved. Enter **1** if you wish to discard the configuration and restart the System Configuration Dialog.

3.2.19.1 Before You Begin

Complete these steps before you run the System Configuration Dialog:

-
- Step 1** Determine the IP address for the Ethernet interface.
 - Step 2** If you plan to configure in-band management, determine the IP address for the ATM interface that will be used for in-band management (ATM0/1 or ATM0/2).
 - Step 3** Find out what the password strategy is for your environment. The System Configuration Dialog window prompts you for three passwords, plus an SNMP community string. The three required password types are enable secret, enable, and virtual terminal.
 - Step 4** Choose a name for the Cisco 6260. (This step is optional.)
-

3.2.19.2 Using the System Configuration Dialog

The System Configuration Dialog offers two configuration options: basic management setup and extended setup.

- Choose basic management setup if you want to use the System Configuration Dialog to configure the passwords and the Ethernet interface only, and then use the management station or the command line interface (CLI) to configure the remaining Cisco 6260 interfaces.
- Choose extended setup if you want to use the System Configuration Dialog to configure all of the Cisco 6260 interfaces.

An example of each type of setup follows the “Interface Numbering” section.

3.2.19.2.1 Interface Numbering

The System Configuration Dialog window and the CLI use the following interface numbering scheme:

- Interfaces whose names begin with “ATM0” (ATM0/0, ATM0/1, and so forth) are NI-2 card network trunk interfaces. ATM0/0 is the ATM switch interface with the processor (sometimes referred to as the ASP interface, for ATM switch/processor). There is no need to configure ATM0/0 unless you plan to use in-band management. ATM0/1 is the trunk port. ATM0/2 and ATM0/3 (if present) are subtending interfaces.

- Interfaces whose names begin with “ATM1” through “ATM32” are line card interfaces. (NI-2 slots, ATM10 and ATM11, are omitted.)
For line card interfaces, the number before the slash indicates the slot number. The number after the slash indicates the interface or port number. For example, ATM6/4 is slot 6, port 4.
- Ethernet0/0 is the interface for the LAN that connects the Cisco 6260 to its management system.

3.2.19.2.2 Basic Management Setup Example

This is the basic management setup example:

```
--- System Configuration Dialog ---

Would you like to enter the initial configuration dialog? [yes/no]: y
At any point you may enter a question mark '?' for help.
Use ctrl-c to abort configuration dialog at any prompt.
Default settings are in square brackets '[]'.

Basic management setup configures only enough connectivity
for management of the system, extended setup will ask you
to configure each interface on the system

Would you like to enter basic management setup? [yes/no]: y

Configuring global parameters:

Enter host name [DSLAM]:

The enable secret is a password used to protect access to
privileged EXEC and configuration modes. This password, after
entered, becomes encrypted in the configuration.
Enter enable secret: beansoup
```

The enable password is used when you do not specify an enable secret password, with some older software versions, and some boot images.

Enter enable password: **beansoup**

% Please choose a password that is different from the enable secret

Enter enable password: **lab1**

The virtual terminal password is used to protect access to the router over a network interface.

Enter virtual terminal password:

% No defaulting allowed

Enter virtual terminal password: **lab**

Configure SNMP Network Management? [yes]: **y**

Community string [public]:

Current interface summary

Any interface listed with OK? value "NO" does not have a valid configuration

Interface	IP-Address	OK?	Method	Status	Protocol
ATM0/0	unassigned	NO	unset	up	up
Ethernet0/0	unassigned	NO	unset	up	up
ATM0/1	unassigned	NO	unset	down	down
ATM0/2	unassigned	NO	unset	down	down

Enter interface name used to connect to the management network from the above interface summary: **Ethernet0/0**

Configuring interface Ethernet0/0:

Configure IP on this interface? [yes]: **y**

IP address for this interface: **172.27.144.141**

Subnet mask for this interface [255.255.0.0] :

Class B network is 172.27.0.0, 16 subnet bits; mask is /16

The following configuration command script was created:

```
hostname DSLAM
enable secret 5 $1$pR/1$0zH7ohDaUKNML3SC2.RF5.
enable password lab1
line vty 0 4
password lab
snmp-server community public
!
no ip routing

!
interface ATM0/0
no ip address
!
interface Ethernet0/0
no shutdown
ip address 172.27.144.141 255.255.0.0
!
interface ATM0/1
shutdown
no ip address
!
interface ATM0/2
shutdown
no ip address
!
end
```



```
[0] Go to the IOS command prompt without saving this config.
[1] Return back to the setup without saving this config.
[2] Save this configuration to nvram and exit.
```

```
Enter your selection [2]: 2
% Shutdown not allowed for ATM0/0.
Building configuration...
Use the enabled mode 'configure' command to modify this configuration.
```

```
Press RETURN to get started!
```

3.2.19.2.3 Extended Setup Example

This is the extended setup example:

```
--- System Configuration Dialog ---
```

```
Continue with configuration dialog? [yes/no]: yes
```

```
At any point you may enter a question mark '?' for help.
Use ctrl-c to abort configuration dialog at any prompt.
Default settings are in square brackets '[]'.
```

```
Basic management setup configures only enough connectivity
for management of the system, extended setup will ask you
to configure each interface on the system
```

```
Would you like to enter basic management setup? [yes/no]: no
```

```
First, would you like to see the current interface summary? [yes]: yes
```

Interface	IP-Address	OK?	Method	Status	Protocol
ATM0/0	70.0.0.2	YES	NVRAM	up	up
Ethernet0/0	172.27.32.156	YES	NVRAM	up	up
ATM0/1	unassigned	YES	unset	down	down
ATM0/2	unassigned	YES	unset	administratively down	down
ATM18/0	unassigned	YES	unset	initializing	down
ATM18/1	unassigned	YES	unset	initializing	down
ATM18/2	unassigned	YES	unset	initializing	down
ATM18/3	unassigned	YES	unset	initializing	down
ATM21/0	unassigned	YES	unset	administratively down	down
ATM21/1	unassigned	YES	unset	administratively down	down
ATM21/2	unassigned	YES	unset	administratively down	down
ATM21/3	unassigned	YES	unset	administratively down	down
ATM26/0	unassigned	YES	unset	down	down
ATM26/1	unassigned	YES	unset	down	down
ATM26/2	unassigned	YES	unset	down	down
ATM26/3	unassigned	YES	unset	down	down

```
Configuring global parameters:
```

```
Enter host name [DSLAM]: sw-ni2-2
```

```
The enable secret is a password used to protect access to
privileged EXEC and configuration modes. This password, after
entered, becomes encrypted in the configuration.
```

```
Enter enable secret: lqb
```

The enable password is used when you do not specify an enable secret password, with some older software versions, and some boot images.

Enter enable password [lab]: **lab**

The virtual terminal password is used to protect access to the router over a network interface.

Enter virtual terminal password [lab]:

Configure SNMP Network Management? [no]:

Configure IP? [yes]:

Configure IGRP routing? [yes]: **no**

Configuring interface parameters:

Do you want to configure ATM0/0 interface? [yes]:

Configure IP on this interface? [yes]:

IP address for this interface [70.0.0.2]:

Subnet mask for this interface [255.0.0.0] :

Class A network is 70.0.0.0, 8 subnet bits; mask is /8

Do you want to configure Ethernet0/0 interface? [yes]:

Configure IP on this interface? [yes]:

IP address for this interface [172.27.32.156]:

Subnet mask for this interface [255.255.0.0] :

Class B network is 172.27.0.0, 16 subnet bits; mask is /16

Do you want to configure ATM0/1 interface? [yes]:

Configure IP on this interface? [no]:

Do you want to configure ATM0/2 interface? [no]:

Do you want to configure ATM18/0 interface? [yes]:

Configure IP on this interface? [no]:

Do you want to configure ATM18/1 interface? [yes]:

Configure IP on this interface? [no]:

Do you want to configure ATM18/2 interface? [yes]:

Configure IP on this interface? [no]:

Do you want to configure ATM18/3 interface? [yes]:

Configure IP on this interface? [no]:

Do you want to configure ATM21/0 interface? [no]:

Do you want to configure ATM21/1 interface? [no]:

Do you want to configure ATM21/2 interface? [no]:

Do you want to configure ATM21/3 interface? [no]:

Do you want to configure ATM26/0 interface? [yes]:

Configure IP on this interface? [no]:

Do you want to configure ATM26/1 interface? [yes]:

Configure IP on this interface? [no]:

Do you want to configure ATM26/2 interface? [yes]:

Configure IP on this interface? [no]:

Do you want to configure ATM26/3 interface? [yes]:

Configure IP on this interface? [no]:

The following configuration command script was created:

```
hostname sw-ni2-2
enable secret 5 $1$12Lo$vGKa1wlRcNyw06j1bgGQd0
enable password lab
line vty 0 4
password lab
no snmp-server
!
ip routing
!
interface ATM0/0
ip address 70.0.0.2 255.0.0.0
!
interface Ethernet0/0
ip address 172.27.32.156 255.255.0.0
!
interface ATM0/1
no ip address
!
interface ATM0/2
shutdown
no ip address
!
interface ATM18/0
no ip address
!
interface ATM18/1
no ip address
!
interface ATM18/2
no ip address
!
interface ATM18/3
no ip address
!
interface ATM21/0
shutdown
no ip address
!
interface ATM21/1
shutdown
no ip address
!
interface ATM21/2
shutdown
no ip address
!
interface ATM21/3
shutdown
no ip address
!
interface ATM26/0
no ip address
!
interface ATM26/1
no ip address
!
interface ATM26/2
no ip address
!
```

```
interface ATM26/3
no ip address
!
end
```

- [0] Go to the IOS command prompt without saving this config.
- [1] Return back to the setup without saving this config.
- [2] Save this configuration to nvram and exit.

```
Enter your selection [2]:2
Building configuration...
Use the enabled mode 'configure' command to modify this configuration.
```

Press RETURN to get started!

**Note**

To configure your system, refer to the appropriate software or network management configuration guides.



Installing a Cisco 6260 Without a POTS Splitter Configuration

This chapter provides installation procedures for a Cisco 6260 without a POTS splitter configuration.



Note

The installation procedures in this chapter apply to a Cisco 6260 system shipped with the individual hardware components already installed. For information about installing or replacing hardware components in the Cisco 6260 chassis, see Chapter 6, “Upgrading and Maintaining the Cisco 6260 System.”



Warning

Only trained and qualified personnel should be allowed to install, replace, or service this equipment.



Caution

Before you begin the installation procedures, read the entire chapter for important information and safety warnings.



Note

Before installing and cabling the equipment, be aware of standard safety practices and the hazards involved in working with electrical circuitry to prevent accidents. See the “Safety Requirements” section on page 2-1 for cautions and warnings that are necessary to ensure a safe and hazard-free installation.

To see translations of the warnings that appear in this publication, refer to the *Regulatory Compliance and Safety Information for the Cisco 6260 System* document.



Tip

See the “Cisco 6260 System Without a POTS Splitter Configuration” section on page 1-4 for more information about Cisco 6260 without a POTS splitter configuration components.

4.1 Installation Checklist

When you install a Cisco 6260 without a POTS splitter configuration, be sure that you follow the installation procedures in the proper sequence. Table 4-1 is a checklist of the installation steps in the order in which they should occur. Detailed installation instructions are located in the sections following Table 4-1.



Caution

Proper ESD protection is required whenever you handle Cisco equipment. Installation and maintenance personnel should be properly grounded using ground straps to eliminate the risk of ESD damage to the equipment. Cards are subject to ESD damage whenever they are removed from the chassis.

Table 4-1 *Installation Checklist—Cisco 6260 without a POTS Splitter Configuration*

Check	Installation Procedure
	1. Measure the rack space.
	2. Attach Cisco 6260 ear brackets.
	3. Install the Cisco 6260 chassis in the rack.
	4. Install the blank faceplates in the open slots.
	5. Ground the Cisco 6260.
	6. Connect the Cisco 6260 chassis to the MDF ¹ .
	7. Attach the Cisco 6260 power connections.
	8. Connect the alarm and BITS clock contacts.
	9. Apply power to the system.
	10. Verify that the fan trays are operational.
	11. Connect the Cisco 6260 system to the network.
	12. Install a subtended network configuration (optional).
	13. Connect the ethernet to the management network.
	14. Connect a console terminal.
	15. Connect the auxiliary port (optional).
	16. Complete the initial configuration.

1. MDF = main distribution frame

4.2 Installation Procedures

The following sections detail the installation procedures for a Cisco 6260 without a POTS splitter configuration.

4.2.1 Measure Rack Space

For the rack to remain stable, you must install your Cisco 6260 system from the bottom to the top of the rack.

Before you install any of the chassis, measure the total rack space required to install your system. The required rack space depends on the number of Cisco 6260 chassis that you plan to use. The number of chassis increases if you plan to install a subtended network.

**Note**

See Chapter 2, “Preparing for Installation,” to determine the total rack space you need for your configuration.

**Warning**

To prevent bodily injury when mounting or servicing this unit in a rack, you must take special precautions to ensure that the system remains stable. The following guidelines are provided to ensure your safety:

—This unit should be mounted at the bottom of the rack if it is the only unit in the rack.

—When mounting this unit in a partially filled rack, load the rack from the bottom to the top with the heaviest component at the bottom of the rack.

—If the rack is provided with stabilizing devices, install the stabilizers before mounting or servicing the unit in the rack.

**Warning**

Two people are required to lift the chassis. Grasp the chassis underneath the lower edge and lift with both hands. To prevent injury, keep your back straight and lift with your legs, not your back.

**Warning**

Never attempt to lift the chassis with the handles on the power supplies, fan trays, or the switching modules. These handles are not designed to support the weight of the chassis. Using them to lift or support the chassis can result in severe damage to the equipment and serious bodily injury.

If you plan to expand your system to include more chassis in the future, allow space in the rack for additions, keeping in mind the weight distribution and stability of the rack.

4.2.2 Attach Ear Brackets to the Cisco 6260

Verify that the ear brackets on the sides of the chassis are in the proper configuration to fit the rack, and if necessary, reinstall them. Ear brackets can be installed in two ways, as shown in Figure 4-1:

Figure 4-1 Mounting Options for Ear Brackets

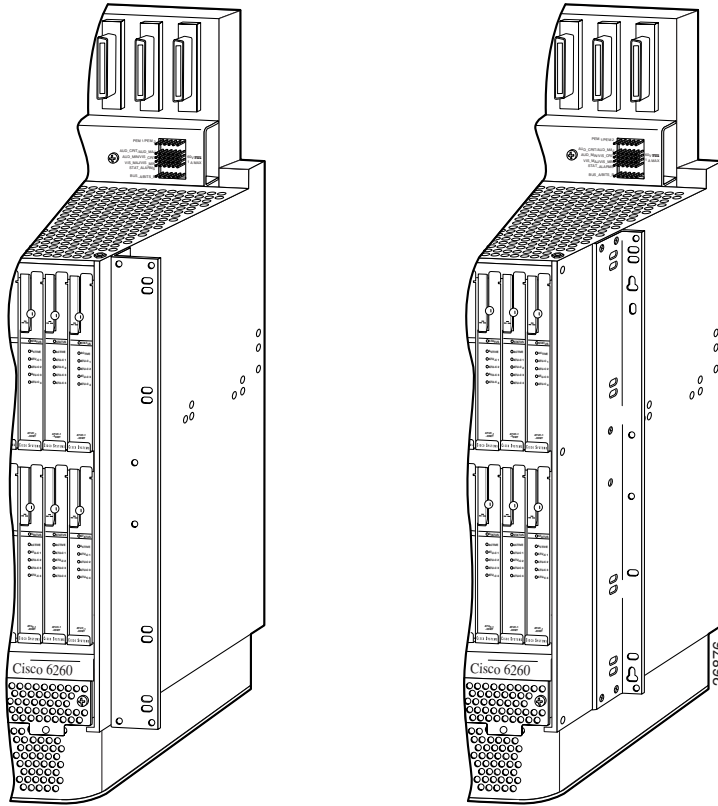

Bracket orientation for
ETSI 600-mm rack

Bracket orientation
for 19-inch rack

For Cisco 6260 installation in an ETSI 600-mm (23-inch) rack, attach the L-shaped ear brackets so that the short sides are against the chassis wall and the long sides protrude from the chassis.

For Cisco 6260 installation in a 19-inch rack, attach the ear brackets so that the long side of each L is against the chassis wall and the short side protrudes from the chassis.



Note

The ear brackets are installed in the factory for a 19-inch rack configuration.

4.2.3 Install the Cisco 6260 Chassis

Complete the following steps to install the Cisco 6260 chassis.



Warning

Two people are required to lift the chassis. Grasp the chassis underneath the lower edge and lift with both hands. To prevent injury, keep your back straight and lift with your legs, not your back.

- Step 1** Connect a grounding strap to the ESD grounding jack that is located on the top right of the front of the Cisco 6260 chassis.
- Step 2** Using a Phillips-head screwdriver, attach the two mounting aids to the rack. Use two screws for each mounting aid, as shown in Figure 4-2. The lower edge of the mounting aid lines up with the bottom of the chassis.

Figure 4-2 Screw the Mounting Aids to the Rack

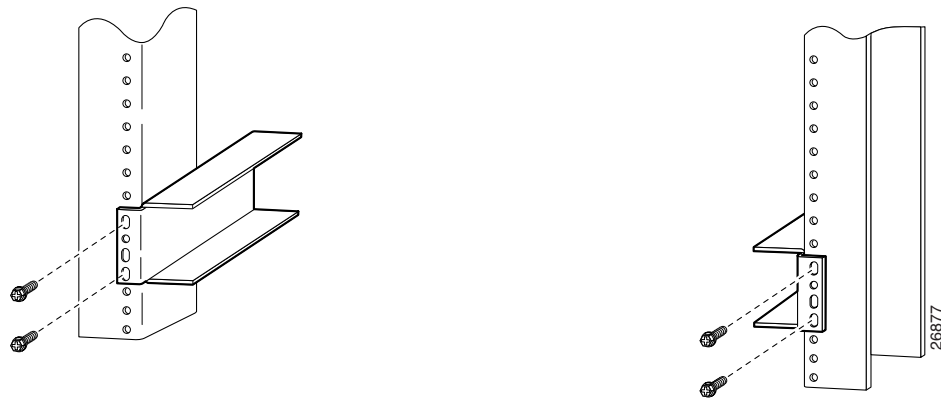

Step 3 Carefully lift the chassis from underneath and rest it on the mounting aids, as shown in Figure 4-3.

Figure 4-3 Mounting Aids Support the Chassis During Installation

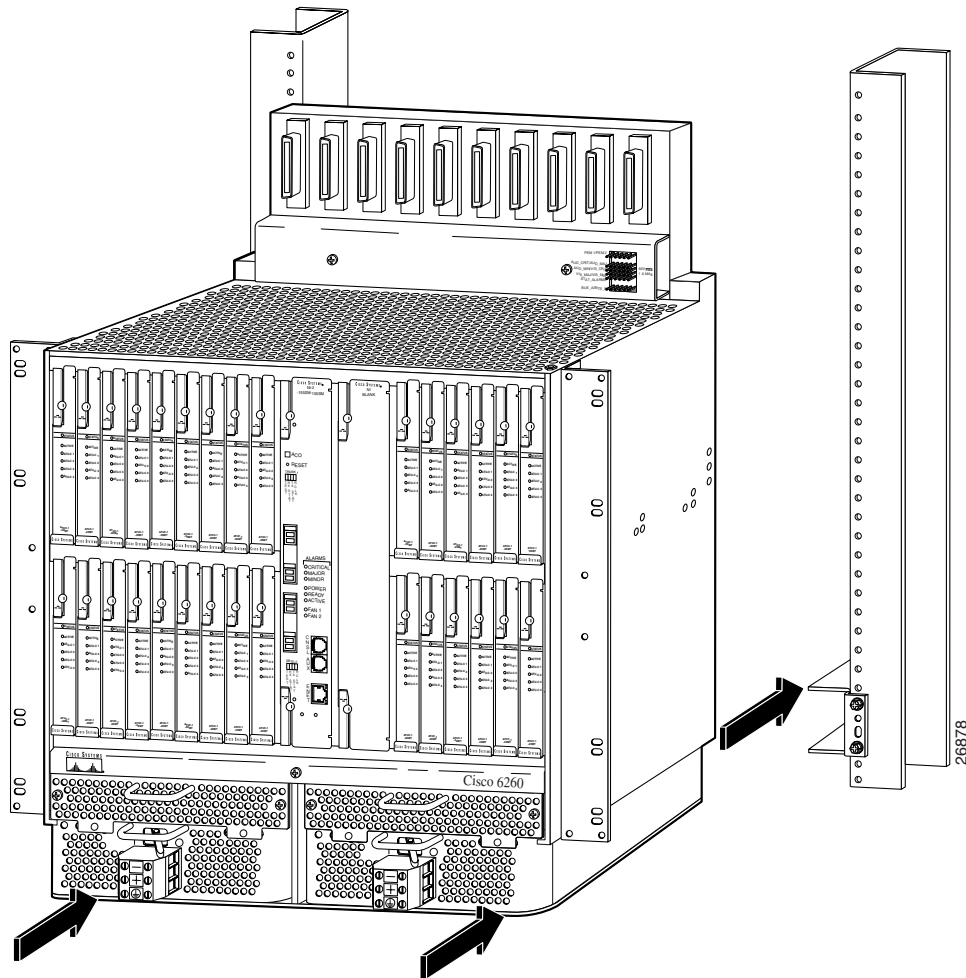

Step 4 Push the chassis back into the rack.

Step 5 Using a Phillips-head screwdriver, screw the ear brackets on the chassis to the rack. Use two screws at the top of each ear bracket and two at the bottom (four screws per bracket). For stability, make sure you use at least one round hole at each end of each bracket (the ear brackets have both round and oval holes).

Step 6 Repeat Step 1 through Step 5 for each Cisco 6260 chassis that you are installing.

4.2.4 Install Blank Faceplates

Blank faceplates should occupy any empty slots in the Cisco 6260 chassis. Blank faceplate installation is similar to line card installation.

Complete the following steps to install blank faceplates in the Cisco 6260:

-
- Step 1** Connect a grounding strap to the ESD grounding jack that is located on the top right of the front of the Cisco 6260 chassis.
 - Step 2** Vertically align the blank faceplate edge with the guides at the top and bottom of the slot.
 - Step 3** Lift up on the ejector tab and gently apply pressure to the bottom of the faceplate while pushing the blank faceplate into the slot.
 - Step 4** Push on the faceplate to fully seat the blank faceplate.
 - Step 5** Press down on the ejector tab to secure the faceplate.
-

4.2.5 Ground the Cisco 6260

Complete the following steps to connect the grounding lug on the Cisco 6260.



Warning

When you are installing the unit, the ground connection must always be made first and disconnected last.



Warning

Before connecting or disconnecting ground or power wires to the chassis, ensure that power is removed from the DC circuit. To ensure that all power is OFF, locate the circuit breaker on the panel board that services the DC circuit, switch the circuit breaker to the OFF position, and tape the switch handle of the circuit breaker in the OFF position. Use a voltmeter to test for 0 (zero) voltage at the power terminals on the chassis.

-
- Step 1** Ensure that power in the direct current (DC) circuit is off.
 - Step 2** Remove all paint or oxidation from the rack at the point of the grounding connection.
 - Step 3** Measure enough wire to connect the Cisco 6260 to the rack. Use 10 American Wire Gauge (AWG) green or green with yellow stripes wire to ground the Cisco 6260 chassis.



Note Use only as much wire as is necessary to make the connection.

- Step 4** Use a wire stripping tool to remove the covering from the end of the grounding wire. The manufacturer of the grounding lug might have a specific recommendation about the length of wire to be stripped.
- Step 5** Insert the stripped end of the grounding wire into the open end of the grounding lug. Be careful not to leave any wire strands outside the lug.
- Step 6** Use the crimping tool to compress the lug onto the wire.
- Step 7** To verify the quality of the crimp, inspect it and tug gently on the wire.
- Step 8** Locate the three grounding holes on the Cisco 6260 side panel. (See Figure 4-4.)
- Step 9** Match the holes in the grounding lug to the appropriately spaced pair of grounding holes on the side of the chassis. Use the top two holes for a 5/8-inch lug, as shown in Figure 4-4. Use the bottom two holes for a 3/4-inch lug.

Figure 4-4 System Ground Connection

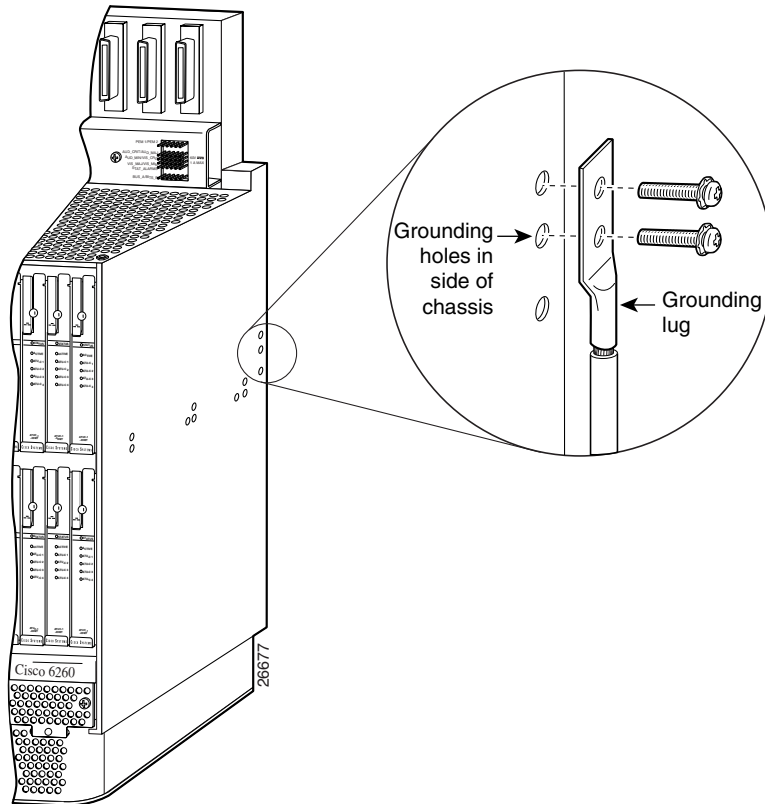

- Step 10** Insert the screws through the holes in the lug and the chassis. Use the Phillips-head screwdriver to tighten the screws and secure the grounding lug firmly to the chassis.
- Step 11** Prepare the other end of the grounding wire and connect it to an appropriate grounding point in your site.
- Step 12** Repeat Step 1 through Step 11 for each Cisco 6260 chassis, as necessary.

4.2.6 Connect the Cisco 6260 to the MDF

Use ten RJ-21 (Champ) cables to connect the Cisco 6260 to the MDF. This connection is for xDSL data flow between the Cisco 6260 and the MDF.

See Appendix B, “Port Mapping Specifications” for port mapping information.

Ensure that all champ connectors are securely screwed in to the connector panel at the top of the Cisco 6260 chassis.



Note

If unshielded cable is used for FCC Class A or EN55022 Class A compliance, the cables must be looped through ferrites.

4.2.7 Attach Cisco 6260 Power Connections

External power is supplied to the system as –48 VDC from the central office (CO) power source or rectifier to the fuse and alarm panel. Power is fed from the fuse and alarm panel to receptacles in terminal blocks located on the power entry modules (PEMs) installed in the Cisco 6260 chassis.

Connect the power connections on each PEM to separate power sources to achieve full power redundancy. If you do not require power redundancy, use the terminals on a single PEM, or connect both PEMs to a single power source.

Complete these instructions to connect the Cisco 6260 system to a –48 VDC power source. Ground the chassis before you attempt this procedure, as described in the “Ground the Cisco 6260” section on page 4-7.

**Note**

See Chapter 2, “Preparing for Installation,” for the calculation tables that you need to determine the minimum power requirements for your system.

**Caution**

To prevent the system from powering up, do not install the fuses at this time. If the fuses are already installed in the fuse and alarm panel, remove them. You can replace the fuses after the system is installed and connected.

Follow these instructions to attach the power connections to the Cisco 6260 PEM:

Step 1

Verify that power in the DC circuit is off.

**Warning**

Before connecting or disconnecting ground or power wires to the chassis, ensure that power is removed from the DC circuit. To ensure that all power is OFF, locate the circuit breaker on the panel board that services the DC circuit, switch the circuit breaker to the OFF (0) position, and tape the switch handle of the circuit breaker in the OFF (0) position. Use a voltmeter to test for 0 (zero) voltage at the power terminals on the chassis.

Step 2

Connect a grounding strap to the ESD grounding jack that is located on the top right of the front of the Cisco 6260 chassis.

Step 3

Prepare the wire for the Cisco 6260 power and grounding connections, as follows:

- a. Measure enough wire (6 to 10 AWG multistranded copper wire) to connect each of the PEM power connections to the fuse and alarm panel, as well as enough to connect the grounding receptacle on the PEM terminal block to the grounding connection at the DC power source.
- b. Cut the ends of the power and ground wires so that the ends are straight, not slanted.
- c. Measure 0.43 inch (11 mm) up from the end of each power and ground wire and place a mark at that point. These are the wire ends that will be connected to the Cisco 6260.
- d. Use the wire stripping tool to remove 0.43 inch (11 mm) of the covering from both ends of each wire. Trim the ends of the covering so that they are straight, as shown in Figure 4-5, not slanted.

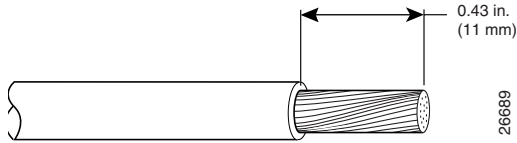
Figure 4-5 Strip and Square Off Power and Ground Wires**Warning**

Remove the covering from exactly the specified length of each power wire. If you strip too much of the covering, exposed wire protruding from the terminal block will create an electrical hazard. If you strip too little of the covering, the wire may not make a good contact with the terminal, or it may not be held securely in place in the terminal block.

Step 4

Use a flat-head screwdriver to turn all three screws on the terminal block counterclockwise to open the terminal connectors: + (positive), – (negative), and ground. This step ensures that the correct opening is presented for the wires, as shown in Figure 4-6.

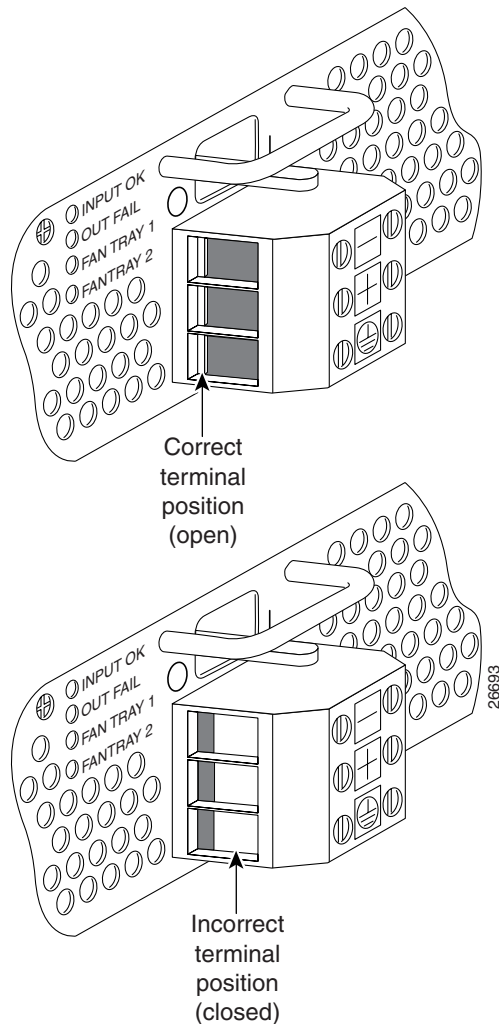
Figure 4-6 Positioning the Power and Ground Terminals to Accept Wires

- Step 5** Insert the end of the grounding wire into the grounding receptacle, which is the bottom receptacle in the terminal block on the PEM (see Figure 4-7). The stripped part of the wire must be fully inserted into the terminal block so that no bare wire is exposed.
- Step 6** Ensure that no wire strands are left outside the connector.
- Step 7** Using the screwdriver and a clockwise motion, tighten the ground screw in the terminal block. Gently tug on the wire to ensure that it is firmly in place.

Figure 4-7 Insert Grounding Wire into Grounding Receptacle

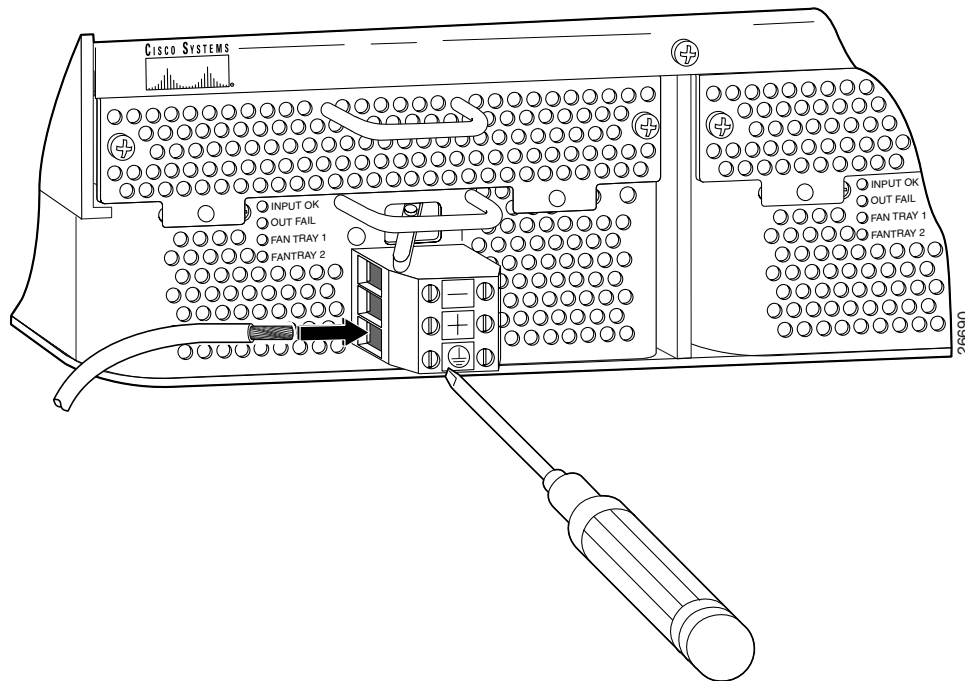

- Step 8** Make sure that the other end of the grounding wire is connected to ground at the DC power source.
- Step 9** If you are connecting two power sources to the Cisco 6260 system, repeat Step 2 through Step 8 for the second PEM.

Warning

Only a DC power source that is isolated from the AC main power source with reinforced insulation, and that complies with the other safety extra-low voltage (SELV) requirements in UL1950, CSA 950 3rd Edition, EN 60950, and IEC950, can be connected to a Cisco 6260 system. This requirement ensures that in a catastrophic power source fault condition, hazardous voltages are not present on power terminals and connectors.

- Step 10** After connecting the battery return wire to the external power source, insert the other end into the receptacle labeled + (positive) on the terminal block of the first PEM, as shown in Figure 4-8. The stripped part of the wire must be fully inserted so that no bare wire is exposed. Using the screwdriver and a clockwise motion, tighten the terminal screw. Gently tug on the wire to ensure that it is firmly in place.

Figure 4-8 Connecting Power to the Terminal Block

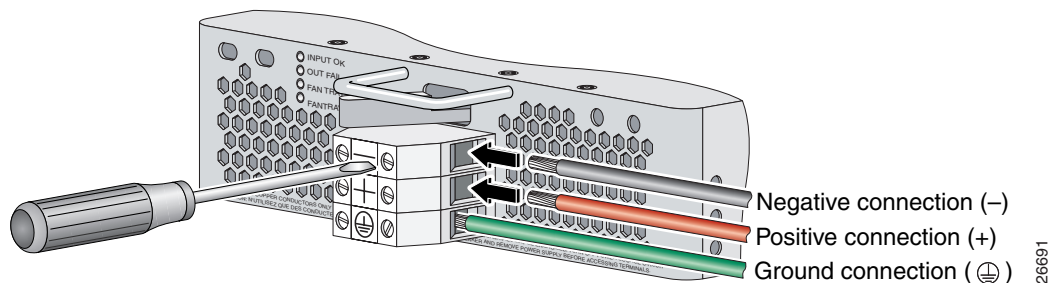

- Step 11** After connecting the power lead to the external –48V power source, insert the other end of the wire into the receptacle labeled – (negative) on the terminal block of the first PEM, as shown in Figure 4-8. The stripped part of the wire must be fully inserted so that no bare wire is exposed. Using the screwdriver and a clockwise motion, tighten the terminal screw. Gently tug on the wire to ensure that it is firmly in place.
- Step 12** If you are connecting a second power source, repeat Step 10 and Step 11 to wire it to the second PEM.



Note Be sure that the chassis is connected to earth ground as described in the “Ground the Cisco 6260” section on page 4-7. The Cisco 6260 requires two or three ground connections, one to the side of the chassis and one to each PEM.

- Step 13** Repeat Step 2 through Step 12 for each Cisco 6260 chassis, as necessary.



Warning Do not yet power up the system.

4.2.8 Connect the Alarm and BITS Clock Contacts



Note Connecting the alarm and BITS clock contacts are optional procedures.

Complete the following steps to connect the external alarm and BITS clock contacts:

- Step 1** Connect the external alarm device and BITS clock to the wire-wrap pins on the I/O module at the top of the chassis.
- Measure one strand of twisted-pair wire (24 AWG industry standard T1/E1 cable) long enough to connect to the appropriate pin.

See Figure 4-9 for a close-up of the pinouts that are located on the I/O module. For pinout descriptions, see the “E1 I/O Module RJ-48c Connectors” section on page C-2.

Figure 4-9 I/O Module Wire-Wrap Pins Close-up

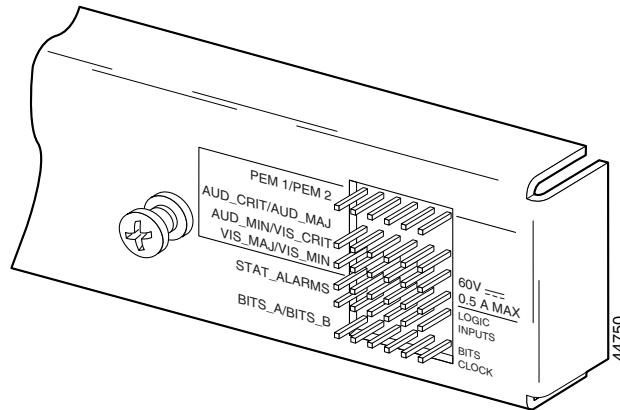

- b. Use a wire stripper to remove the casing from both ends of the wire.
- c. Use a wire-wrapping tool to attach the wire to the appropriate pin.
- d. Use a wire-wrapping tool to attach the other end of the wire that is used in Step 1c to either the BITS clock source or alarm relay contact.
- e. Repeat this step to wire-wrap all the necessary pins.



Note The BITS pins on Cisco 6260 I/O cards are slot specific. BITS_A pins are assigned to chassis slot 11 and BITS_B pins are assigned to chassis slot 10. Each BITS clock input is independent and terminated at 100 ohms.

- Step 2** Reboot the system to reassociate the system MAC address.
- Step 3** Repeat Step 1 and Step 2 for each Cisco 6260 chassis, as necessary.

4.2.9 Apply Power

Complete the following steps to apply power to the Cisco 6260 system:

- Step 1** Apply power to the system with one of the following methods:
 - Install the fuses in the fuse and alarm panel.
 - Reinsert the fuses in the fuse and alarm panel, if you removed them in the “Attach Cisco 6260 Power Connections” section on page 4-9.
 - Turn on the breakers in the fuse and alarm panel.



Caution

If the power connections are improperly made and power is applied while the cards are installed, the cards and chassis could be damaged.

- Step 2** Verify that the power connections are made correctly, as described in the “Attach Cisco 6260 Power Connections” section on page 4-9.
- Step 3** Check the polarity of the –48 VDC connections to each chassis by attaching a voltmeter with the minus lead on –48RTN and the plus lead on –48V_A or –48V_B. Ensure that the meter reads between –40.5 VDC and –75 VDC. If your voltmeter shows a positive voltage, check to ensure that the meter leads are not reversed. If the voltmeter shows a negative voltage that is out of the –40.5 VDC to –75 VDC range, check the power supply for failure or check for a blown fuse in the fuse and alarm panel.
- Step 4** Turn on power to the DC circuit.
- Step 5** Use a voltmeter to check the voltage at the terminal block. Connect the voltmeter positive contact to the positive (+) terminal on the Cisco 6260 terminal block. Connect the voltmeter negative contact to the negative (–) terminal on the Cisco 6260 terminal block. If the power is wired correctly, you will see a reading of –48V on the voltmeter.
- Step 6** At the front of the chassis, switch the circuit breakers on both PEMs to the ON (1) position.
- Step 7** Repeat Step 1 through Step 6 for each Cisco 6260 chassis, as necessary.
-

4.2.10 Verify Fan Tray Operation

Verify that the fan trays are operational by checking the fan tray LEDs, located on the PEMs that are installed beneath the fan trays. If the LED is

- Green—The fan is operational.
- Not green—The fan is not operational and the fan tray may be in alarm mode. See Chapter 5, “Troubleshooting,” for corrective action.



Caution

The fans in both fan trays must run continuously. The system might suffer thermal damage if the fans in either tray stop for more than 5 minutes.

4.2.11 Connect the Cisco 6260 System to the Network

The following sections provide instructions for making E3, E1, and OC-3c network connections from the Cisco 6260 system.

4.2.11.1 E3 Network Connection

The E3 network connection is made from E3 I/O module. Complete the following steps to connect the E3 I/O module to the network.



Tip

We recommend that you label each data cable at both ends to identify its destination.

- Step 1** Verify that you have both a DS3/2DS3 NI-2 card and an E3 I/O module installed in the Cisco 6260 chassis.

The E3 I/O module connections marked P1 attach to the ATM switch. Two 75-ohm Bayonet-Neill-Concelman (BNC) connectors for E3 transmit (TX) and receive (RX) are provided. See Figure 4-10 for the location of the P1 BNC connectors.

Figure 4-10 E3 I/O Module BNC Connectors

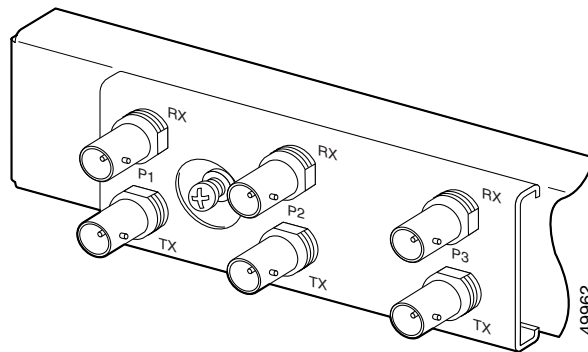

- Step 2** Attach one end of a coaxial cable (type 734A or equivalent) to the P1 TX BNC connector on the E3 I/O module.



Note See Table 2-4 on page 2-16 for cable requirements.

- Step 3** Attach the other end of the cable to the ATM switch.
- Step 4** Attach one end of a coaxial cable (type 734A or equivalent) to the P1 RX BNC connector on the E3 I/O module.
- Step 5** Attach the other end of the cable to the ATM switch.
- Step 6** Repeat Step 1 through Step 5 for each Cisco 6260 chassis, as necessary.

4.2.11.2 E1 Network Connection

The E1 network connection is made from E1 I/O module. Complete the following steps to connect the E1 I/O module to the network:

- Step 1** Verify that you have both a DS3+T1/E1 IMA NI-2 card and an E1 I/O module installed in the Cisco 6260 chassis.

The E1 I/O module connections attach to the ATM switch. Cisco provides four sets of two vertically paired E1 RJ-48c (120-ohm) connectors that can be used as network trunk connections, individual E1 subtend links, connections to IMA subtending groups, or connections to IMA group trunk interfaces. See Figure 4-11 for the location of the E1 RJ-48 receptacle connectors.

Figure 4-11 E1 I/O Module BNC Connectors

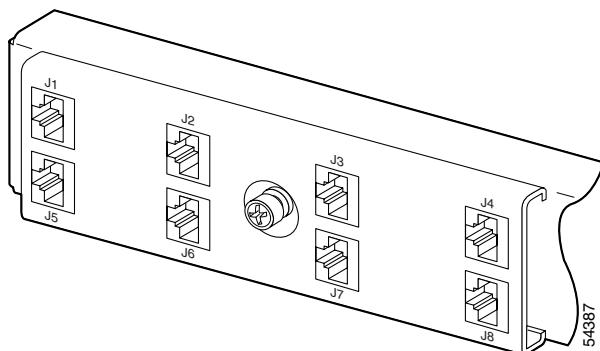

- Step 2** Connect one end of an RJ-45 cable to one of the RJ-48 receptacle connectors on the E1 I/O module. If you have a subtended network configuration installed, this connection must be made to the E1 I/O module in the subtending host chassis.



Note If unshielded cable is used for FCC Class B or EN55022 Class B compliance, the cables must be looped through ferrites.

See Table 2-4 on page 2-16 for cable requirements.

- Step 3** Connect the other end of the cable used in Step 2 to the ATM switch.



Note Verify that the pinouts of the RJ-45 cable connect transmit to receive and receive to transmit.

- Step 4** Repeat Step 1 through Step 3 for each Cisco 6260 chassis, as necessary.



Note Use the procedures in this section to make IMA network connections. See the “IMA Configuration” section on page 1-4 for more information on IMA network connections.

4.2.11.3 OC-3c Network Connection

OC-3c network connections are made from the OC-3c/OC-3c NI-2 card. Complete the following steps to connect the OC-3c/OC-3c NI-2 card to the network.



Warning

Do not stare into the beam or view it directly with optical instruments.

- Step 1** Verify that an OC-3c/OC-3c NI-2 card is in slot 10 of the Cisco 6260 chassis (or slot 11, if you are installing a secondary card for NI-2 redundancy).

- Step 2** Attach the RX cable from the ATM switch to the trunk 1 (TRNK 1) TX connector in the inset on the NI-2 card faceplate. The TX connector is the one closer to the top of the faceplate. The connector IDs are silkscreened inside the inset. See Figure 1-18 for the location of OC-3c network interface connectors.
- Step 3** Attach the TX cable from the ATM switch to the TRNK 1 RX connector in the inset on the NI-2 card faceplate. The RX connector is closer to the bottom of the faceplate. See Figure 1-18 for the location of OC-3c network interface connectors.
- Step 4** Repeat Step 1 through Step 3 for each Cisco 6260 chassis, as necessary.

4.2.12 Install a Subtended Network Configuration

If you are installing a subtended network configuration, complete the steps in the following sections, which provide installation procedures for E3, E1, and OC-3c subtended network configurations.

If you are not installing a subtended network, proceed to the “Connect the Ethernet to the Management Network” section on page 4-19.



Note

For overview information on a subtended network configuration, see the “Subtended Network Configuration” section on page 1-6.

4.2.12.1 Connect the E3 Subtending Network Configuration

Coaxial connections for E3 subtending cabling are located on the I/O module. The P1 TX and RX BNC connectors are reserved for network trunk cabling, or for upstream cabling from a subtended node chassis to the host. The P2 or P3 TX and RX BNC connectors on the subtending host chassis I/O module are connected to the P1 TX and RX BNC connectors on the subtended node chassis I/O module.

Figure 4-12 shows the three sets of BNC connectors and their location on the E3 I/O module.

Figure 4-12 E3 I/O Module BNC Connectors

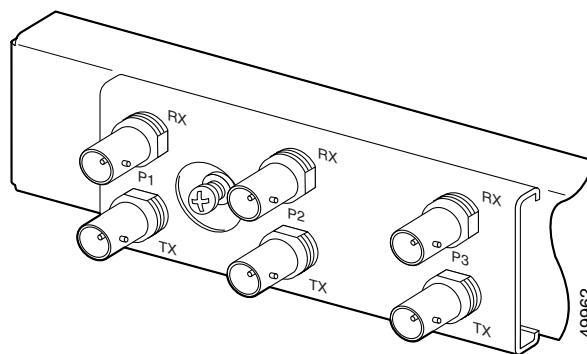

Complete the following steps to cable the E3 I/O module for subtending:

- Step 1** On the subtending host chassis I/O module, attach one end of a BNC cable to the P2 (or P3) TX BNC connector.

- Step 2** On the first subtended node chassis I/O module, attach the other end of the cable to the P1 RX BNC connector.
- Step 3** On the subtending host chassis I/O module, attach one end of a BNC cable to the P2 or (P3) RX BNC connector.
- Step 4** On the first subtended node chassis I/O module, attach the other end of the cable to the P1 TX BNC connector.
- Step 5** Repeat Step 1 through Step 4 to connect the subtending host chassis to each subtended node chassis.

See Figure 1-3 for an illustration of an E3 subtending network configuration.

4.2.12.2 Connect the E1 Subtending Network Configuration

Connections for E1 subtending cabling are located on the I/O module. The RJ-48 E1 connectors on the subtending host chassis I/O module are connected to the RJ-48 E1 connectors on the subtended node chassis I/O module.

Figure 4-13 shows the eight RJ-48 E1 connectors and their location on the E1 I/O module.

Figure 4-13 E1 I/O Module RJ-48 Connectors

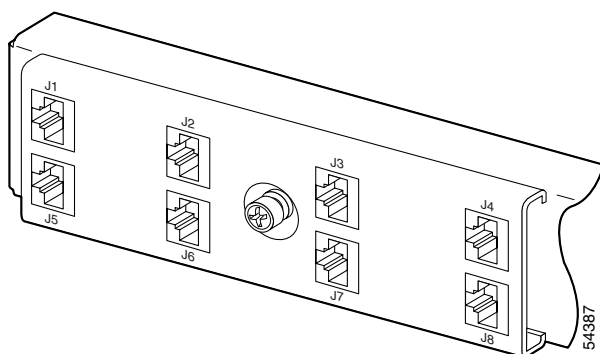

Complete the following steps to cable the I/O module for E1 subtending:

- Step 1** Connect one end of an RJ-45 crossover cable to one of the RJ-48 receptacle connectors on the subtending host chassis E1 I/O module.
- Step 2** Connect the other end of the cable to one of the RJ-48 receptacle connectors on the subtended node chassis E1 I/O module.
- Step 3** Repeat Step 1 and Step 2 to connect the subtending host chassis to each subtended node chassis.



Note If you are using an E1 trunk to the network, the trunk connection originates at one of the RJ-48 receptacle connectors on the E1 I/O module. Therefore, you can have only seven subtended node chassis.

See Figure 1-4 for an illustration of an E1 subtending network configuration.

4.2.12.3 Connect the OC-3c Subtending Network Configuration

Connections for OC-3c subtending are made from the faceplate of the OC-3c/OC-3c NI-2 card installed in the subtending host chassis to the faceplate of the OC-3c/OC-3c NI-2 card installed in the subtended node chassis. See Figure 1-18 for the location of the OC-3c subtending connectors on the faceplate of the NI-2 card.

To cable the Cisco 6260 system for OC-3c subtending, complete the following steps:

-
- Step 1** Locate the TRNK 1 network interface connectors (TX and RX) and the subtend (SBTD) 2 interface connectors (TX and RX) on the front of each OC-3c/OC-3c NI-2 card.
 - Step 2** Attach an OC-3c fiber-optic cable to the SBTD 2 TX interface connector on the NI-2 card installed in the subtending host chassis.
 - Step 3** Attach the other end of the cable to the TRNK 1 RX interface connector on the NI-2 card installed in the subtended node chassis.
 - Step 4** Attach an OC-3c fiber-optic cable to the SBTD 2 RX interface connector on the NI-2 card installed in the subtending host chassis.
 - Step 5** Attach the other end of the cable to the TRNK 1 TX interface connector on the NI-2 card installed in the subtended node chassis.
 - Step 6** To cable your system for APS link redundancy, repeat Step 1 through Step 5 for the secondary NI-2 cards installed in slot 11 of each host and subtending chassis.
-

See Figure 1-5 for an illustration of an OC-3c subtending network configuration.

4.2.13 Connect the Ethernet to the Management Network



Warning

The ports labeled "ENET," "CNLSL," and "AUX" are safety extra-low voltage (SELV) circuits. SELV circuits should be connected only to other SELV circuits. Because the DSL circuits are treated like telephone-network voltage, avoid connecting the SELV circuit to the telephone network voltage (TNV) circuits.



Timesaver

We recommend that you label each data cable at both ends to identify its destination.

Complete the following steps to connect the Ethernet to the management network:

-
- Step 1** Connect the Ethernet cable to the NI-2 card ENET receptacle (see Figure 1-18 for the location of the ENET receptacle on the faceplate of the NI-2 card).



Note

See Table 2-4 on page 2-16 for cable and ferrite requirements.

- Step 2** Run the cable through the ferrite one time, loop the cable back through the ferrite, and clamp the ferrite shut.
- Step 3** Connect the other end of the cable to the management network (for example, a LAN).

4.2.14 Connect a Console Terminal

Connect a VT100-compatible terminal to the NI-2 card CNSL receptacle (see Figure 1-18 for the location of the CNSL receptacle on the faceplate of the NI-2 card). Connect the terminal to a power source and set it up using the values shown in Table 4-2.



Warning

The ports labeled "ENET," "CNSL," and "AUX" are SELV circuits. SELV circuits should be connected only to other SELV circuits. Because the DSL circuits are treated like telephone-network voltage, avoid connecting the SELV circuit to the TNV circuits.

Table 4-2 Terminal Settings

Baud rate	9600 to 38,400 bps (transmit and receive)
Character size	8 bits
Parity	None
Stop bits	1
Flow control	None

4.2.15 Connect the Auxiliary Port

Connect a terminal, a modem, or another serial device to the NI-2 card RJ-45 AUX receptacle (see Figure 1-18 for the location of the AUX receptacle on the faceplate of the NI-2 card).



Note

This action is optional.



Warning

The ports labeled "ENET," "CNSL," and "AUX" are SELV circuits. SELV circuits should be connected only to other SELV circuits. Because the DSL circuits are treated like telephone-network voltage, avoid connecting the SELV circuit to the TNV circuits.



Timesaver

We recommend that you label each data cable at both ends to identify its destination.

4.2.16 Complete Initial Configuration

When you turn on the Cisco 6260 for the first time, an interactive dialog called the System Configuration Dialog appears in a window on the console screen. The System Configuration Dialog guides you through the initial configuration process. (You can run the dialog at any time by entering the **setup** command in privileged EXEC mode.)

When you complete the dialog, the system displays the configuration command script that you have created. It then offers you three options:

```
[0] Go to the IOS command prompt without saving this config.  
[1] Return back to the setup without saving this config.  
[2] Save this configuration to nvram and exit.
```

If you enter **2**, the configuration is saved and used. If you answer **0** or **1**, the configuration you created is not saved. Enter **1** if you wish to discard the configuration and restart the System Configuration Dialog.

4.2.16.1 Before You Begin

Complete these steps before you run the System Configuration Dialog:

-
- | | |
|---------------|--|
| Step 1 | Determine the IP address for the Ethernet interface. |
| Step 2 | If you plan to configure in-band management, determine the IP address for the ATM interface that will be used for in-band management (ATM0/1 or ATM0/2). |
| Step 3 | Find out what the password strategy is for your environment. The System Configuration Dialog window prompts you for three passwords, plus an SNMP community string. The three required password types are enable secret, enable, and virtual terminal. |
| Step 4 | Choose a name for the Cisco 6260. (This step is optional.) |
-

4.2.16.2 Using the System Configuration Dialog

The System Configuration Dialog offers two configuration options: basic management setup and extended setup.

- Choose basic management setup if you want to use the System Configuration Dialog to configure the passwords and the Ethernet interface only, and then use the management station or the command line interface (CLI) to configure the remaining Cisco 6260 interfaces.
- Choose extended setup if you want to use the System Configuration Dialog to configure all of the Cisco 6260 interfaces.

An example of each type of setup follows the “Interface Numbering” section.

4.2.16.2.1 Interface Numbering

The System Configuration Dialog window and the CLI use the following interface numbering scheme:

- Interfaces whose names begin with “ATM0” (ATM0/0, ATM0/1, and so forth) are NI-2 card network trunk interfaces. ATM0/0 is the ATM switch interface with the processor (sometimes referred to as the ASP interface, for ATM switch/processor). There is no need to configure ATM0/0 unless you plan to use in-band management. ATM0/1 is the trunk port. ATM0/2 and ATM0/3 (if present) are subtending interfaces.

- Interfaces whose names begin with “ATM1” through “ATM32” are line card interfaces. (NI-2 slots, ATM10 and ATM11, are omitted.)
For line card interfaces, the number before the slash indicates the slot number. The number after the slash indicates the interface or port number. For example, ATM6/4 is slot 6, port 4.
- Ethernet0/0 is the interface for the LAN that connects the Cisco 6260 to its management system.

4.2.16.2.2 Basic Management Setup Example

This is the basic management setup example:

```
--- System Configuration Dialog ---

Would you like to enter the initial configuration dialog? [yes/no]: y
At any point you may enter a question mark '?' for help.
Use ctrl-c to abort configuration dialog at any prompt.
Default settings are in square brackets '[]'.

Basic management setup configures only enough connectivity
for management of the system, extended setup will ask you
to configure each interface on the system

Would you like to enter basic management setup? [yes/no]: y

Configuring global parameters:

Enter host name [DSLAM]:

The enable secret is a password used to protect access to
privileged EXEC and configuration modes. This password, after
entered, becomes encrypted in the configuration.
Enter enable secret: beansoup
```

The enable password is used when you do not specify an enable secret password, with some older software versions, and some boot images.

Enter enable password: **beansoup**

% Please choose a password that is different from the enable secret

Enter enable password: **lab1**

The virtual terminal password is used to protect access to the router over a network interface.

Enter virtual terminal password:

% No defaulting allowed

Enter virtual terminal password: **lab**

Configure SNMP Network Management? [yes]: **y**

Community string [public]:

Current interface summary

Any interface listed with OK? value "NO" does not have a valid configuration

Interface	IP-Address	OK?	Method	Status	Protocol
ATM0/0	unassigned	NO	unset	up	up
Ethernet0/0	unassigned	NO	unset	up	up
ATM0/1	unassigned	NO	unset	down	down
ATM0/2	unassigned	NO	unset	down	down

Enter interface name used to connect to the management network from the above interface summary: **Ethernet0/0**

Configuring interface Ethernet0/0:

Configure IP on this interface? [yes]: **y**

IP address for this interface: **172.27.144.141**

Subnet mask for this interface [255.255.0.0] :

Class B network is 172.27.0.0, 16 subnet bits; mask is /16

The following configuration command script was created:

```
hostname DSLAM
enable secret 5 $1$pR/1$0zH7ohDaUKNML3SC2.RF5.
enable password lab1
line vty 0 4
password lab
snmp-server community public
!
no ip routing

!
interface ATM0/0
no ip address
!
interface Ethernet0/0
no shutdown
ip address 172.27.144.141 255.255.0.0
!
interface ATM0/1
shutdown
no ip address
!
interface ATM0/2
shutdown
no ip address
!
end
```

```
[0] Go to the IOS command prompt without saving this config.
[1] Return back to the setup without saving this config.
[2] Save this configuration to nvram and exit.
```

```
Enter your selection [2]: 2
% Shutdown not allowed for ATM0/0.
Building configuration...
Use the enabled mode 'configure' command to modify this configuration.
```

```
Press RETURN to get started!
```

4.2.16.2.3 Extended Setup Example

This is the extended setup example:

```
--- System Configuration Dialog ---
```

```
Continue with configuration dialog? [yes/no]: yes
```

```
At any point you may enter a question mark '?' for help.
Use ctrl-c to abort configuration dialog at any prompt.
Default settings are in square brackets '['].
```

```
Basic management setup configures only enough connectivity
for management of the system, extended setup will ask you
to configure each interface on the system
```

```
Would you like to enter basic management setup? [yes/no]: no
```

```
First, would you like to see the current interface summary? [yes]: yes
```

Interface	IP-Address	OK?	Method	Status	Protocol
ATM0/0	70.0.0.2	YES	NVRAM	up	up
Ethernet0/0	172.27.32.156	YES	NVRAM	up	up
ATM0/1	unassigned	YES	unset	down	down
ATM0/2	unassigned	YES	unset	administratively down	down
ATM18/0	unassigned	YES	unset	initializing	down
ATM18/1	unassigned	YES	unset	initializing	down
ATM18/2	unassigned	YES	unset	initializing	down
ATM18/3	unassigned	YES	unset	initializing	down
ATM21/0	unassigned	YES	unset	administratively down	down
ATM21/1	unassigned	YES	unset	administratively down	down
ATM21/2	unassigned	YES	unset	administratively down	down
ATM21/3	unassigned	YES	unset	administratively down	down
ATM26/0	unassigned	YES	unset	down	down
ATM26/1	unassigned	YES	unset	down	down
ATM26/2	unassigned	YES	unset	down	down
ATM26/3	unassigned	YES	unset	down	down

```
Configuring global parameters:
```

```
Enter host name [DSLAM]: sw-ni2-2
```

```
The enable secret is a password used to protect access to
privileged EXEC and configuration modes. This password, after
entered, becomes encrypted in the configuration.
```

```
Enter enable secret: lqb
```

The enable password is used when you do not specify an enable secret password, with some older software versions, and some boot images.

Enter enable password [lab]: **lab**

The virtual terminal password is used to protect access to the router over a network interface.

Enter virtual terminal password [lab]:

Configure SNMP Network Management? [no]:

Configure IP? [yes]:

Configure IGRP routing? [yes]: **no**

Configuring interface parameters:

Do you want to configure ATM0/0 interface? [yes]:

Configure IP on this interface? [yes]:

IP address for this interface [70.0.0.2]:

Subnet mask for this interface [255.0.0.0] :

Class A network is 70.0.0.0, 8 subnet bits; mask is /8

Do you want to configure Ethernet0/0 interface? [yes]:

Configure IP on this interface? [yes]:

IP address for this interface [172.27.32.156]:

Subnet mask for this interface [255.255.0.0] :

Class B network is 172.27.0.0, 16 subnet bits; mask is /16

Do you want to configure ATM0/1 interface? [yes]:

Configure IP on this interface? [no]:

Do you want to configure ATM0/2 interface? [no]:

Do you want to configure ATM18/0 interface? [yes]:

Configure IP on this interface? [no]:

Do you want to configure ATM18/1 interface? [yes]:

Configure IP on this interface? [no]:

Do you want to configure ATM18/2 interface? [yes]:

Configure IP on this interface? [no]:

Do you want to configure ATM18/3 interface? [yes]:

Configure IP on this interface? [no]:

Do you want to configure ATM21/0 interface? [no]:

Do you want to configure ATM21/1 interface? [no]:

Do you want to configure ATM21/2 interface? [no]:

Do you want to configure ATM21/3 interface? [no]:

Do you want to configure ATM26/0 interface? [yes]:

Configure IP on this interface? [no]:

Do you want to configure ATM26/1 interface? [yes]:

Configure IP on this interface? [no]:

Do you want to configure ATM26/2 interface? [yes]:

Configure IP on this interface? [no]:

Do you want to configure ATM26/3 interface? [yes]:

Configure IP on this interface? [no]:

The following configuration command script was created:

```
hostname sw-ni2-2
enable secret 5 $1$12Lo$vGKa1w1RcNyw06j1bgGQd0
enable password lab
line vty 0 4
password lab
no snmp-server
!
ip routing
!
interface ATM0/0
ip address 70.0.0.2 255.0.0.0
!
interface Ethernet0/0
ip address 172.27.32.156 255.255.0.0
!
interface ATM0/1
no ip address
!
interface ATM0/2
shutdown
no ip address
!
interface ATM18/0
no ip address
!
interface ATM18/1
no ip address
!
interface ATM18/2
no ip address
!
interface ATM18/3
no ip address
!
interface ATM21/0
shutdown
no ip address
!
interface ATM21/1
shutdown
no ip address
!
interface ATM21/2
shutdown
no ip address
!
interface ATM21/3
shutdown
no ip address
!
interface ATM26/0
no ip address
!
interface ATM26/1
no ip address
!
interface ATM26/2
no ip address
!
```

```
interface ATM26/3
no ip address
!
end
```

```
[0] Go to the IOS command prompt without saving this config.
[1] Return back to the setup without saving this config.
[2] Save this configuration to nvram and exit.
```

```
Enter your selection [2]:2
Building configuration...
Use the enabled mode 'configure' command to modify this configuration.
```

```
Press RETURN to get started!
```

**Note**

To configure your system, refer to the appropriate software or network management configuration guides.



Troubleshooting

This chapter explains how to isolate faults in the Cisco 6260 system. Most problems in a Cisco 6260 can be traced to one of the system field-replaceable units (FRUs), which include the following:

- NI-2 cards
- Line cards
- Input/Output (I/O) modules
- Power entry modules (PEMs)
- Fan trays
- Air filters

This chapter consists of three major sections:

- System-Wide Problems, page 5-3
- FRU-Specific Problems, page 5-8
- Alarms, page 5-17

5.1 Hot-Swappable FRUs

All Cisco 6260 FRUs are hot swappable, except the PEM in configurations where only a single PEM is operating. However, hot swapping some FRUs causes an interruption in service. See Table 5-1.

Table 5-1 Service Interruptions Caused by Replacing FRUs

FRU	Does Hot Swapping Interrupt Service?	Notes
NI-2 card	Yes	In systems with NI-2 card redundancy, the secondary card can be hot swapped without incurring service interruption for the system.
Line card	Yes	Service is interrupted only for subscribers served by that line card.
I/O module	Yes	You must reboot the system after you replace the I/O module because the MAC address is stored on the I/O module.
PEM	See next column	You can replace a PEM without interrupting service if the other PEM in the chassis is operating normally.

Table 5-1 Service Interruptions Caused by Replacing FRUs

FRU	Does Hot Swapping Interrupt Service?	Notes
Fan tray	No	—
Air filter	No	—

5.2 Basic Checks

Before using the troubleshooting tables in this chapter, make the following basic checks:

- Are the ports properly configured? Refer to these sources for configuration instructions:
 - *Configuration Guide for Cisco DSLAMs with NI-2*
 - *Command Reference for Cisco DSLAMs with NI-2*
 - Cisco IOS information on the World Wide Web—
http://www.cisco.com/univercd/cc/td/doc/product/dsl_prod/ios_dsl/
 - *ATM Switch Router Software Configuration Guide*
 - *ATM Switch Router Command Reference Guide*
- Are power leads and data cables firmly connected at both ends?
- Are all cards firmly seated and securely locked in the chassis?
- Is the fan tray properly installed and secured to the chassis?
- Are the network I/O module and PEMs properly secured to the chassis?

5.3 Contacting the Cisco TAC for Help

In certain situations, the troubleshooting tables in this chapter direct you to contact the Cisco Technical Assistance Center (TAC) for help. If you have a maintenance contract or if your hardware is under warranty, call the TAC at 800 553 2447 (North America only), 408 526 7209, or visit this URL for a worldwide list of TAC regional telephone numbers:

<http://www.cisco.com/warp/public/687/Directory/DirTAC.shtml>

5.4 System-Wide Problems

Table 5-2 offers suggestions for problems that affect the entire Cisco 6260 system.

Table 5-2 System-Wide Problems

Symptom	Steps to Take
System fails to come up.	<ol style="list-style-type: none"> 1. Check the Power LED on the NI-2, the Status LEDs on the line cards, and the Input OK LED on each PEM. If all LEDs are off, or if the red Out Fail LED on either PEM is on, troubleshoot the PEMs. See the “Alarms” section on page 5-17. 2. If any green LEDs are on, the system has power. Check the STATUS LED on the NI-2 card. If the STATUS LED is off, refer to the “NI-2 Card Problems” section on page 5-8. 3. If the Cisco 6260 is set to boot from a remote device over the network, make sure the remote device is up, that its network connection is solid, and that it contains the boot file. (The Cisco 6260 tries to boot over the network for a configured period, usually 5 to 15 minutes. If it is unable to boot over the network, it will eventually boot from bootflash.) 4. Try to establish a console connection to the Cisco 6260. If you cannot connect, see the steps for the symptom You cannot establish a console or Telnet connection to the system., page 5-4. 5. If you achieve a console connection <ul style="list-style-type: none"> – Examine the command prompt. If the prompt says <code>rommon 1></code>, the problem could be in flash memory, in bootflash, in an incorrectly set boot configuration register, or in an incorrect file name in a boot system command in the startup-config file. Refer to the <i>Configuration Guide for Cisco DSLAMs with NI-2</i> for information on setting and interpreting configuration registers, configuring flash memory, and editing the startup-config file. To select an image to boot the system from flash, enter dir flash:. In the resulting display, find the name of the software image. Then enter boot flash:imagenam, replacing <i>imagenam</i> with the name of the software image. The system boots from flash. – If you see a normal Cisco IOS prompt, which usually contains the name of the system (default is <code>c6260</code>), enter show oir status. If the results indicate that the card is loading software, wait a few minutes for the port to come back up.

Table 5-2 System-Wide Problems (continued)

Symptom	Steps to Take
You cannot establish a console or Telnet connection to the system.	<ol style="list-style-type: none"> 1. For a console problem, check the terminal settings against the list of settings in the “Connect a Console Terminal” section on page 3-21 or the “Connect a Console Terminal” section on page 4-20. 2. For a Telnet problem: <ul style="list-style-type: none"> – If you are connecting to the Cisco 6260 through the Ethernet interface, check the configuration of your LAN for both the Cisco 6260 and the Telnet source. – If you are connecting to the Cisco 6260 through an ATM interface, make sure that PVCs are set up between the two devices and that the map-list is correctly configured. Enter the command show running-config to display this information. – If the Telnet source and the Cisco 6260 are on different networks, make sure static routes are configured at both ends so that the two devices can communicate. To check, use the ping command to ping each device from the other (that is, ping the Cisco 6260 from the Telnet source, and ping the Telnet source from the Cisco 6260). Alternatively, ping your default gateways from each end of the connection. 3. For both console and Telnet problems: <ul style="list-style-type: none"> – Check the cabling and connectors between the terminal or Telnet source and the Cisco 6260. See Appendix C, “Connector and Pinout Specifications,” to check pinouts. – Press the Reset button on the NI-2 card faceplate to reset the card. – If the problem persists, replace the NI-2 card.
System experiences a critical, major, or minor alarm.	<ol style="list-style-type: none"> 1. Enter the command show facility-alarm status. Note the affected slot and port, if any, and the description of the problem. 2. If no slot number is indicated, enter show environment all and examine the results for an indication of which FRU is at fault. Refer to the “FRU-Specific Problems” section on page 5-8 for instructions on troubleshooting that FRU. 3. If ATM0/0, ATM0/1, ATM0/2, or ATM0/3 is indicated: <ul style="list-style-type: none"> – Enter a show int command for the interface (for example, show int atm0/1). Results may indicate a SONET problem (Loss of Signal, for example). Refer to the “NI-2 Card Problems” section on page 5-8 for instructions on troubleshooting the NI-2 card. – Enter show controllers commands for all trunk and subtending ports. (The ports are atm0/1, atm0/2, and, in a DS3 system, atm0/3.) For example, show controllers atm0/1. In the resulting display, check that the framing mode is set to the same value on this interface as at the other end of the connection. Also check that cell payload scrambling is on (on E3 interfaces only). 4. If a line card slot is indicated, consult the “NI-2 Card Redundancy Problems” section on page 5-9.

Table 5-2 System-Wide Problems (continued)

Symptom	Steps to Take
A trunk or subtending port fails to come up (OC-3c or E3).	<ol style="list-style-type: none"> 1. Check the cable connections at both ends. Refer to “” section on page B-2 to check pinouts. 2. To check the interface status and configuration, enter show interface atm slot#/port#. Check the following in the resulting display: <ul style="list-style-type: none"> – If the port Admin Status is down, enter the commands below to correct the problem, replacing slot/port ID atm 0/1 with your slot/port ID: <pre data-bbox="542 516 1089 669"> DSLAM> configure terminal Enter configuration commands, one per line. End with CNTL/Z. DSLAM(config-if)# int atm 0/1 DSLAM(config-if)# no shutdown DSLAM(config-if)#</pre> – If the port IF Status is down, check for disconnected or faulty cables. (Optical cables connect to the NI-2 card; E3 coaxial cables connect to the I/O module on the front of the chassis.) – If the Line Protocol is down, the line protocol software processes might have determined that the line is unusable. Try swapping the cable. Another possibility is that clocking might be misconfigured, or the clocking source might have failed. – Check the CRC field. The presence of many CRC errors but not many collisions is an indication of excessive noise. If the number is too high (greater than 0.5 to 2 percent of total traffic on the interface), check the cables to determine if any are damaged. <p data-bbox="493 1024 1498 1087">If you need more information on interface configuration, refer to the <i>Configuration Guide for Cisco DSLAMs with NI-2</i> and the <i>ATM Switch Router Software Configuration Guide</i>.</p> 3. For an E3 interface: enter show controllers atmslot#/port#. Check the following in the resulting display: <ul style="list-style-type: none"> – Framing mode must be the same at both ends of the connection. – Cell payload scrambling must be on at both ends of the connection. 4. Check the status and configuration of the interface at the far end. 5. If you need to run a loopback test, do the following: <ul style="list-style-type: none"> – In interface configuration mode, enter loopback diagnostic or loopback line. – Set the external test equipment to loop data through the Cisco 6260 port. – Obtain loopback results from your external test equipment. – Enter no loopback diagnostic to take the port out of loopback mode. 6. In interface configuration mode, reset the trunk port by executing the shutdown command followed by the no shutdown command. 7. Replace the NI-2 card. 8. If the problem with an E3 interface persists, troubleshoot the I/O module. See the “I/O Module Problems” section on page 5-14.

Table 5-2 System-Wide Problems (continued)

Symptom	Steps to Take
A trunk or subtending port fails to come up (E1).	<ol style="list-style-type: none"> 1. Verify that the trunk port selection is correct. 2. Check the cable connections at both ends. Refer to Appendix C, “Connector and Pinout Specifications,” to check pinouts. 3. To check the interface status and configuration, enter show interface atm slot#/port#. Check the following information in the resulting display: <ul style="list-style-type: none"> – If the port Admin Status is down, enter the commands below to correct the problem, replacing slot/port ID atm 0/2 with your slot/port ID (atm 0/2 through atm 0/9): <pre> DSLAM> configure terminal Enter configuration commands, one per line. End with CNTL/Z. DSLAM(config-if)# int atm 0/2 DSLAM(config-if)# no shutdown DSLAM(config-if)# </pre> – If the port IF Status is down, check for disconnected or faulty wire. T1/E1 twisted pair wire connects to the I/O module on the front of the chassis. – If the Line Protocol is down, the line protocol software processes might have determined that the line is unusable; try swapping the cable. Another possibility is that clocking might be misconfigured, or the clocking source might have failed. – Check the CRC field. The presence of many CRC errors but not many collisions is an indication of excessive noise. If the number is too high (greater than 0.5 to 2 percent of total traffic on the interface), check the cables to determine if any are damaged. <p>If you need more information on interface configuration, refer to the <i>Configuration Guide for Cisco DSLAMs with NI-2</i> and the <i>ATM Switch Router Software Configuration Guide</i>.</p> 4. Enter show controllers atm slot#/port#. Check the following information in the resulting display: <ul style="list-style-type: none"> – Framing mode must be the same at both ends of the connection. – Line coding must be the same at both ends of the connection (E1). – Cell payload scrambling must be on at both ends of the connection. 5. Check the status and configuration of the interface at the far end. 6. If you need to run a loopback test to troubleshoot the E1 links, do the following tasks: <ul style="list-style-type: none"> – In interface configuration mode, enter loopback diagnostic (or loopback line). – Set the external test equipment to loop data through the Cisco 6260 port. – Obtain loopback results from your external test equipment. – Enter no loopback diagnostic (or no loopback line) to take the port out of loopback mode. 7. In interface configuration mode, reset the trunk port by executing the shutdown command followed by the no shutdown command. 8. Replace the NI-2 card. 9. If the problem with a T1/E1 interface persists, troubleshoot the network I/O module. See the “I/O Module Problems” section on page 5-14.

Table 5-2 System-Wide Problems (continued)

Symptom	Steps to Take
A trunk or subtending port fails to come up (E1 IMA).	<ol style="list-style-type: none"> Before checking IMA interface problems, troubleshoot the E1 links that are configured in the IMA group, as described in the previous section. Verify that the links are up. Check an IMA interface status with the show ima interface atm0/imaX command, where X is the IMA interface ID (0 through 3). Look at the following items in the resulting display: <ul style="list-style-type: none"> MinNumLinks (minimum number of links) should be equal to or below the number of links you have configured in your IMA group. You can change the minimum number of links parameter in the IMA group to any value from 1 to 8. NeTxClkMode (near end transmit clock mode) should match the FeTxClkMode (far end transmit clock mode), which will be either ctc or itc. Both sides of the IMA link must use the same IMA clock mode. DiffDelayMaxObs (maximum observed differential delay) should be less than DiffDelayMax (maximum differential delay configured for the group). If the differential delay observed is more than the maximum allowed, one or more links is not allowed in the IMA group. Configure more allowable differential delay (up to 69 ms in T1, 55 ms in E1) using T1/E1 lines with less differential delay, or reconfigure similarly-delayed lines into IMA groups if possible. The IMA Link Information table shows the interfaces configured in your IMA group, the near end and far end receive state, and any IMA alarms received at the near end. The NeRxState and FeRxState must both be active for each line to be active in the IMA group. The whole IMA group is up when the number of active links on both sides is equal to or greater than the minimum number of configured links (MinNumLinks) for that IMA group. It can take several seconds for an IMA group to synchronize between two IMA systems. Wait 5 minutes after configuring or reconfiguring a group to allow the synchronization to occur. If synchronization does not occur in any one link or in the group after several minutes, or links cannot be successfully added to an active group, and the above IMA parameters have been checked and are found to be correct, clear the interface with a clear interface atm0/imaX command. This resets the IMA group and starts the IMA synchronization process again with all links in the group. To check the interface status and configuration, enter show interface atm slot#/imagroup#. Check the following information in the resulting display: <ul style="list-style-type: none"> If the port Admin Status is down, enter the commands below to correct the problem, replacing slot/port ID atm0/ima2 with your slot/port ID: <pre> DSLAM> configure terminal Enter configuration commands, one per line. End with CNTL/Z. DSLAM(config-if)# int atm0/ima2 DSLAM(config-if)# no shutdown DSLAM(config-if)# </pre> <p>If you need more information on interface configuration, refer to the <i>Configuration Guide for Cisco DSLAMs with NI-2</i> and the <i>ATM Switch Router Software Configuration Guide</i>.</p> In interface configuration mode, reset the port by executing the shutdown command followed by the no shutdown command.

Table 5-2 System-Wide Problems (continued)

Symptom	Steps to Take
	<ol style="list-style-type: none"> 7. Replace the NI-2 card. 8. If the problem with an E1 interface persists, troubleshoot the I/O module. See the “I/O Module Problems” section on page 5-14.
System overheats.	Troubleshoot the fan tray. See the “Fan Tray Problems” section on page 5-15.
System experiences a clocking problem.	Troubleshoot the NI-2 card. See the “NI-2 Card Problems” section on page 5-8.
System experiences a power problem.	Troubleshoot the PEMs. See the “Alarms” section on page 5-17.

5.5 FRU-Specific Problems

The following sections describe symptoms that might occur and the steps that you need to take if you experience problems with any Cisco 6260 FRU.

5.5.1 NI-2 Card Problems

If you need to remove or replace an NI-2 card as part of the troubleshooting steps below, see Chapter 6, “Upgrading and Maintaining the Cisco 6260 System,” for instructions.

Table 5-3 NI-2 Card Problems

Symptom	Steps to Take
Power LED is off.	<ol style="list-style-type: none"> 1. Check the Status LEDs on the line cards and the Input OK LED on each PEM. If all LEDs are off, or if the red Out Fail LED on either PEM is on, troubleshoot the PEMs—see the “PEM Problems” section on page 5-16. 2. If the line card STATUS LEDs are lit, remove the NI-2 card from its slot and check for bent or broken pins on both the card and the backplane. If you find damaged pins on the card, replace it. If you find damaged pins on the backplane, contact the Cisco TAC.
Status LED is off, indicating that the NI-2 card failed to boot or failed its power-on self test.	Press the Reset button on the NI-2 card. If the problem persists, replace the card.
Critical LED, Major LED, or Minor LED is on.	See the “System-Wide Problems” section on page 5-3.
A trunk or subtending port fails to come up.	See the “System-Wide Problems” section on page 5-3.
NI-2 card cannot be fully inserted into its slot.	Inspect connectors on both the card and the backplane, looking for obstructions, bent pins, or other damage. If you find damage to a line card connector, replace the line card. If you find damage to a backplane connector, contact the Cisco TAC.

5.5.2 NI-2 Card Redundancy Problems

Table 5-4 provides information about symptoms and corrective actions related to NI-2 card cold redundancy problems. If you need to remove or replace an NI-2 card as part of the troubleshooting steps below, see Chapter 6, “Upgrading and Maintaining the Cisco 6260 System,” for instructions.

Table 5-4 NI-2 Card Cold Redundancy Problems

Symptom	Steps to Take
Both NI-2 cards go active.	Ensure that both NI-2 cards are Revision AO or later
DS3 traffic interrupted.	<ol style="list-style-type: none"> 1. Ensure that both NI-2 cards are Revision AO or later. 2. Ensure that the correct boot image is installed on the NI-2 cards. Refer to the <i>Upgrading DSLAMs for NI-2 Card and APS Link Redundancy</i> document for instructions.
Line card communication is interrupted.	<ol style="list-style-type: none"> 1. Ensure that both NI-2 cards are Revision AO or later. 2. Ensure that the correct boot image is installed on the NI-2 cards. Refer to the <i>Upgrading DSLAMs for NI-2 Card and APS Link Redundancy</i> document for instructions.
Transient environmental alarms occur.	<ol style="list-style-type: none"> 3. Ensure that the correct boot image is installed on the NI-2 cards. Refer to the <i>Upgrading DSLAMs for NI-2 Card and APS Link Redundancy</i> document for instructions.
TFTP boot fails.	The NI-2 card is not configured to boot from flash. Refer to the <i>Upgrading DSLAMs for NI-2 Card and APS Link Redundancy</i> document for instructions.
Line cards reboot or reset upon switchover.	The software versions on the primary and secondary NI-2 cards might be mismatched. Use the Cisco IOS show version command to determine the IOS release currently installed on each of the NI-2 cards. Refer to the <i>Upgrading DSLAMs for NI-2 Card and APS Link Redundancy</i> document for more information on upgrading software images.
Redundant NI2 will not become active	Be sure that you have enabled the command no auto-sync bootflash in the redundancy configuration mode if you are using OC3 NI2's with different product numbers (for example, an NI2-155SM-155SM or NI2-155MM-155MM with an NI2-155SM-155SM2 or NI2-155MM-155MM2). Different types of NI2's require different bootflash image types to operate properly.

5.5.3 Line Card Problems

If you need to remove or replace a line card as part of the troubleshooting steps below, see Chapter 6, “Upgrading and Maintaining the Cisco 6260 System,” for instructions.

Table 5-5 Line Card Problems

Symptom	Steps to Take
All LEDs are off.	<ol style="list-style-type: none"> 1. Check the Power LED on the NI-2 card and the Input OK LEDs on the PEMs. If none of the LEDs are lit, or if the red Out Fail LED on either PEM is lit, troubleshoot the PEM—see the “Alarms” section on page 5-17. 2. If the NI-2 card Power LED is off, remove the card from its slot and check for bent or broken pins on both the card and the backplane. If you find damaged pins on the card, replace it. If you find damaged pins on the backplane, contact the Cisco TAC.
All ports on a card fail to come up (modems do not train). Status LED might be red, indicating that the line card failed to boot or failed its power-on self test.	<ol style="list-style-type: none"> 1. Enter the show ipc nodes command to find out whether there is a communication problem between the line card and the NI-2 card. There should be an entry in the resulting display for each line card (“SMB IP Slot <i>n</i>”) and for the NI-2 card (“IPC Master”). If there is an entry for each card, go to step 4. 2. If one or more cards are not listed, enter show oir status. If the resulting display indicates that the card in question is loading new code, wait a few minutes and reenter the command. (Usually, 2 to 3 minutes is long enough to wait.) The card status should change to <code>running</code>. 3. Enter the command show dsl int atm slot#/port#. If the status says <code>Microcode downloading</code>, wait 10 minutes. When the download is complete, the card reboots and comes up normally. 4. Check the ALARM LEDs on the NI-2 card or enter show facility-alarm status to determine the alarm status of the system. If any alarms are indicated, see the “System-Wide Problems” section on page 5-3 for instructions on how to troubleshoot alarms. 5. Enter the command show dsl status and examine the results to ensure that the card is configured to be in its current slot. (In the Names column of the resulting display, the slot number appears as part of the port ID. For example, in ATM19/2, the slot number is 19. Nothing is displayed for slots that are not configured.) If necessary, use the slot command to update the configuration, or move the card to the correct slot. If the line card is a 4xflexi¹, it will not function unless you use the slot command to configure either CAP or DMT operation. 6. Reset the line card by disconnecting it from the backplane and reseating it in its slot. 7. Install the card in another slot. 8. If the problem persists, replace the line card.

Table 5-5 Line Card Problems (continued)

Symptom	Steps to Take
Port fails to come up (modems do not train), or port LED flashes continuously.	<ol style="list-style-type: none"> 1. Enter the command show dsl int atm slot#/port# to display the port configuration. Check the display to ensure that the port is properly provisioned. Make sure the port is configured to be running (“no shutdown” or IOS admin state = up). Also check the line status; if this reads “No CPE detected,” troubleshoot the CPE device and the loop as described below under the symptom “You suspect a problem with the CPE or the subscriber loop.” section on page 5-11. 2. In interface configuration mode, reset the port by executing the shutdown command followed by the no shutdown command. 3. Connect the subscriber to another port on the Cisco 6260. If the modems do not train, troubleshoot the CPE device and the loop as described below under the symptom “You suspect a problem with the CPE or the subscriber loop.” section on page 5-11. If the modems train, go to the next step to troubleshoot the port that failed. 4. To test the modem on the line card, enter dsl test atm slot#/port# self. Results are displayed automatically after a few seconds. If the modem fails the test, replace the line card.
You suspect a problem with the CPE or the subscriber loop.	<ol style="list-style-type: none"> 1. Disconnect the local loop and replace it with a test setup that consists of a modem or CPE that is known to work, and a few thousand feet of wire. If the modems train over the shorter distance, the problem lies in the local loop or in the CPE. See the steps that follow. If the modems do not train, the port is probably at fault. Replace the line card. 2. Make sure that the CPE at the subscriber site is powered up. 3. Make sure that the CPE is compatible with the Cisco 6260, and that the software version running on the CPE is compatible with the software version running on the Cisco 6260. 4. Power cycle the CPE. When you turn the power on, the WAN Link LED on the CPE should blink. If the LED does not blink, check the CPE configuration—if the interface is shut down, bring it up. 5. Perform a continuity check to find out if the cabling to the CPE is connected and intact. For example, if there is a phone on the line, check for a dial tone. 6. If there is no POTS, check DC resistance by shorting tip and ring at the remote end. 7. Make sure there are no load coils on the local loop. 8. Is the local loop too long? The maximum length range is 15,000 to 25,000 feet (4572 to 7620 meters). Within that range, wire gauge, crosstalk, and multiple bridge taps reduce the distance over which the modems can train. 9. Is the local loop too short? DMT modems train best over loops of several thousand feet. In a test situation with a loop just a few feet in length, the modem might fail to train. Add wire to the loop. 10. Replace the CPE.

Table 5-5 Line Card Problems (continued)

Symptom	Steps to Take
<p>Modems train at a low bit rate, modems retrain continuously, or the line experiences too many errors.</p>	<ol style="list-style-type: none"> 1. Enter the command show dsl int atm slot#/port# to display the port configuration. Check the display to ensure that the port is properly provisioned. Look in particular for these statistics: <ul style="list-style-type: none"> – Attenuation: typically this is 20 to 50 dB. If the attenuation value is higher than 50 dB, it might be depressing the bit rate. Repair or replace the cables and connectors in the loop. – SNR margin: 3 to 6 dB is optimum. Use the dmt margin command to adjust SNR margin. – Correction ratio: under DSL Statistics, look at the Received Superframes and Corrected Superframes values. A ratio of more than 1 corrected superframe for every 10 superframes received is too high. One or more of these adjustments might correct the problem: increase the SNR margin using the dmt margin command; increase error correction using the dmt check-bytes command; or increase interleaving using the dmt interleaving-delay command. – Errored seconds: a rate of 10 to 20 errored seconds per minute or more is likely to cause retraining. (1 or 2 errored seconds every 15 minutes is a good rate.) See the steps that follow on crosstalk and impulse noise for suggestions on how to compensate. – CRC errors: normal rates vary system by system. If the CRC error rate is higher than usual, it might cause excessive retraining. See the steps that follow on crosstalk and impulse noise for suggestions on how to compensate. 2. Crosstalk is caused by interference between services in adjacent cables. It affects random bits rather than chunks of data; upstream and downstream traffic can be affected differently. If crosstalk is increasing the bit error rate (BER), you can compensate in several ways: <ul style="list-style-type: none"> – Reduce the bit rate using the dmt bitrate command. (See the <i>Command Reference for Cisco DSLAMs with NI-2</i> for information on the dmt bitrate command.) – Increase the SNR margin using the dmt margin command. (See the <i>Command Reference for Cisco DSLAMs with NI-2</i> for information on the dmt margin command.) – Turn on or increase error correction. Use the dmt check-bytes command. If the codeword size is not set to auto, you might need to use the dmt codeword-size command to adjust the codeword setting. (See the <i>Command Reference for Cisco DSLAMs with NI-2</i> for information on these commands.) 3. If you experience impulse noise or clipping, both of which affect chunks of data rather than random bits, you can compensate by turning on or increasing interleaving and error correction. (However, note that this approach adds delay.) Use the dmt interleaving-delay command for interleaving. Use the dmt encoding-trellis command or the dmt check-bytes command for error correction. If you use dmt check-bytes and if the codeword size is not set to auto, you might need to use the dmt codeword-size command to adjust the codeword setting.

Table 5-5 Line Card Problems (continued)

Symptom	Steps to Take
Modems train at a low bit rate, modems retrain continuously, or the line experiences too many errors (continued).	<ol style="list-style-type: none"> 4. If errors or retraining occurs while the line is ringing, use the dmt interleaving-delay command to turn on interleaving. 5. In interface configuration mode, reset the port by executing the shutdown command followed by the no shutdown command. 6. Connect the customer to a different port on the Cisco 6260. If the modems train, replace the line card with the faulty port. 7. Troubleshoot the CPE device and the loop as described above under the symptom “You suspect a problem with the CPE or the subscriber loop.” section on page 5-11. 8. Replace the line card.
Card cannot be fully inserted into its slot.	<ol style="list-style-type: none"> 1. Remove the card and reinsert it, pushing firmly on both the top and the bottom of the faceplate. (The card might jam in the slot if you apply pressure to the top only.) If the chassis is full, you might need to push sideways to insert the card. 2. Inspect connectors on both the card and the backplane, looking for obstructions, bent pins, or other damage. If you find damage to a line card connector, replace the line card. If you find damage to a backplane connector, contact the Cisco TAC.
Card experiences problems in one slot but operates normally in another.	There may be a fault in your backplane. Contact the Cisco TAC.

1. 4xflexi = quad-port flexi ATU-C line card

5.5.4 I/O Module Problems

If you need to remove or replace an I/O module as part of the troubleshooting steps below, see Chapter 6, “Upgrading and Maintaining the Cisco 6260 System,” for instructions.

Table 5-6 I/O Module Problems

Symptom	Steps to Take
A trunk port fails to come up.	See the “System-Wide Problems” section on page 5-3.
A subtending port fails to come up.	See the “System-Wide Problems” section on page 5-3.
An alarm relay or BITS circuit fails.	<ol style="list-style-type: none"> 1. Check the connection at the wire-wrap connector on the I/O module. See Table C-1 on page C-3 for the pin assignments of the wire-wrap connector. 2. Check the connection at the other end of the circuit. 3. For a BITS problem, troubleshoot the E1 line at the other end of the circuit. 4. Replace the I/O module (except in the case of a circuit breaker alarm problem).
This message appears on the console or in the system log file: <pre>00:00:28:%C6100-4-COOKIE: Corrupt or missing MAC address cookie using random base 007e.eb7d.e700</pre>	<ol style="list-style-type: none"> 1. Make sure the software release running on your system is compatible with the hardware. The Cisco 6260 requires Cisco IOS Release 12.1(4)DA or greater. 2. Enter the command show hardware chassis. In the resulting display, look for data from the I/O module EEPROM. If the system can read the contents of the EEPROM, the I/O module is likely to be healthy. 3. If the I/O module is missing, install it. 4. If the I/O module is present, reseal it. First, turn off system power. Use a Phillips-head screwdriver to unfasten the screws that secure the I/O module cover, and pull the card off the connectors. Push it firmly back into place and tighten the screws. 5. If the problem persists, replace the I/O module.

5.5.5 Fan Tray Problems

If you need to remove or replace a fan tray as part of the troubleshooting steps below, see Chapter 6, “Upgrading and Maintaining the Cisco 6260 System,” for instructions.

Table 5-7 Fan Tray Problems

Symptom	Steps to Take
Fans do not run.	<ol style="list-style-type: none"> 1. Make sure the fan trays are fully inserted into the chassis and screwed in place. 2. Replace the fan tray.
Fans run, but the system overheats.	<ol style="list-style-type: none"> 1. Make sure that the air intake vents at the bottom front of the chassis and the exhaust vents on the top of the chassis are free of blockages, as explained in the Ventilation, page 2-12. 2. Make sure that the ambient temperature and other environmental factors affecting the system are within the ranges specified in the “Environmental Requirements” section on page 2-11. 3. Make sure that all cards, blank faceplates, and covers are in place. The cooling system cannot operate effectively unless the chassis is fully enclosed. 4. Check the fan tray LEDs on the PEMs. If the LEDs show a problem, replace the indicated fan tray. 5. Check the air filter at the bottom of the fan tray, and if necessary clean or replace it. See the “Removing and Replacing the Fan Tray” section on page 6-4 for instructions on cleaning or replacing the air filter. 6. Reduce the ambient temperature.
Air filter is damaged, dirty, or clogged.	Refer to Chapter 6, “Upgrading and Maintaining the Cisco 6260 System” for instructions on cleaning or replacing air filters.

5.5.6 PEM Problems

If you need to remove or replace a PEM as part of the troubleshooting steps below, see Chapter 6, “Upgrading and Maintaining the Cisco 6260 System,” for instructions.

Table 5-8 PEM Problems

Symptom	Steps to Take
Input OK LED on PEM fails to go on.	<ol style="list-style-type: none"> 1. Make sure the circuit breaker on the PEM is turned to the ON (1) position. 2. Make sure the PEM is properly seated in the chassis and screwed in place. 3. Make sure the power leads are properly connected to power connectors on the PEM. (If the connections are loose or their polarity is reversed on the DC PEM, the chassis does not receive power.) 4. Check the power cable for breaks, cracked insulation, loose lugs, and signs of wear. Replace the power cable if it is not in good condition. 5. Check the power source. 6. Turn the circuit breaker on the PEM to the OFF (0) position, and move it to the other PEM slot. If the PEM still fails, replace it.
Out Fail LED on PEM goes on.	<ol style="list-style-type: none"> 1. Make sure the PEM is fully inserted into its slot and firmly screwed in place. 2. Replace the PEM. 3. If the problem persists, there may be a fault in your backplane. Contact the Cisco TAC.
Circuit breaker on PEM trips.	A tripped circuit breaker indicates a serious overcurrent situation. The probable cause is a faulty backplane, a faulty power connector on the backplane, or a faulty PEM. Contact the Cisco TAC for assistance.
PEM has problems in one slot but operates normally in the other.	There might be a fault in your backplane. Contact the Cisco TAC.

5.6 Alarms

Tables 5-9 through 5-20 describe alarms for the Cisco 6260. In each table, the text in the Alarm column is the text that appears in the description field of the alarm message. Alarm messages appear on the console screen as the alarms occur; to see a list of current alarms, enter the **show facility-alarm status** command.

Refer to the problem tables in this chapter for more detailed troubleshooting instructions.

Table 5-9 Chassis Alarm

Alarm	Severity	Description
Chassis temperature too high	Major	A temperature too high for the safe operation of the chassis has been detected. (Temperature is measured on the NI-2 card.)

Table 5-10 Card Slot Alarms

Alarm	Severity	Description
Provisioned slot is empty	Major	The card in this slot does not match the type configured for this slot.
Line card not equal to provisioning	Minor	This slot is configured for a card, but no card is present.
Invalid line card for this slot	Minor	The card detected in this slot cannot operate in this slot or is incompatible with the system configuration.

Table 5-11 Line Card Alarms

Alarm	Severity	Description
ATU-C port failure	Minor	The ATUC-DMT line card port failed.
Upstream rate below min. rate	Minor	The upstream bit rate on this port is not above the configured minimum rate.
Downstream rate below min. rate	Minor	The downstream bit rate on this port is not above the configured minimum rate.
LOS, LOF, LOCD, or LPR failure	Minor	The modem reports a near-end LOS, LOF, or LOCD or a far-end LPR (loss of power) failure. (The line must be enabled to alarm on failures.)

Table 5-12 IOS Controller Alarms

Alarm	Severity	Description
Loss of active clock sync	Major	Loss of timing reference. The configured clock source is not available, so the system is using its internal clock.
BITS clock failure	Major	BITS clock failure (LOS or AIS). The configured clock source is not available, so the system is using its internal clock.

The source of the OC-3c alarms in Table 5-13 is one of the following interfaces: ATM0/1 (the trunk) or ATM0/2 (the subtending interface).

Table 5-13 OC-3c/Synchronous Transfer Mode (STM-1) Network Interface Alarms

Alarm	Severity	Description
Loss of Cell Delineation	Critical	Loss of cell delineation on a SONET line.
Path RDI Received	Critical	Path Remote Defect Indication was received on a SONET line. This is equivalent to Path Far End Receive Failure (FERF).
Path AIS Received	Critical	Path Alarm Indication Signal was received on a SONET line.
Loss of Pointer	Critical	Loss of pointer condition on a SONET line.
Line RDI	Critical	Line Remote Defect Indication received on a SONET line. This is equivalent to line Far End Receive Failure (FERF).
Line AIS Received	Critical	Line Alarm Indication Signal received on a SONET line.
Loss of Frame	Critical	LOF condition on a SONET line.
Loss of Signal	Critical	LOS detected on the SONET line.
Signal Label Mismatch	Minor	Incorrect payload type signal label mismatch on a SONET line.

The source of the E3 alarms in Table 5-14 is one of the following interfaces: ATM0/1 (the trunk), ATM0/2 (subtending interface), or ATM0/2 (subtending interface).

Table 5-14 DS3/E3 Network Interface Alarms

Alarm	Severity	Description
Loss of Cell Delineation	Critical	The DS3/E3 line is experiencing a loss of cell delineation.
RAI Received	Critical	The DS3/E3 line is receiving a remote alarm indication.
Yellow Alarm Received	Critical	The DS3/E3 line is receiving a yellow alarm, indicating that another device has detected a failure that might be in this device.
AIS Received	Critical	The DS3/E3 line is receiving an Alarm Indication Signal.
OOF Received	Critical	The DS3/E3 line has detected an Out of Frame condition.
LOS Detected	Critical	The DS3/E3 line has detected Loss of Signal at the framer.
PLCP LOF Detected	Critical	The DS3/E3 line has detected a Physical Layer Convergence Procedure Loss of Frame error.

The source of the E1 alarms in Table 5-15 is one of the following interfaces: ATM0/2 through ATM0/9 (the trunk).

Table 5-15 E1 Network Interface Alarms

Alarm	Severity	Description
LOS Detected	Critical	The E1 line has detected a loss of signal at the framer.
AIS Received	Critical	The E1 line is receiving an alarm indication signal.
RAI Received	Critical	The E1 line is receiving a remote alarm indication.
LOF Detected (red alarm)	Critical	The E1 line has detected a loss of frame error.
LCD	Critical	The E1 line is experiencing a loss of cell delineation.

The source of the IMA link alarms in Table 5-16 is one of the following interfaces: ATM0/2 through ATM0/9.

Table 5-16 IMA Link Network Interface Alarms

Alarm	Severity	Description
LOS Detected	Critical	The IMA link has detected Loss of Signal at the framer.
LOF Detected	Critical	The IMA link has detected a Physical Layer Convergence Procedure Loss of Frame error.
AIS Received	Critical	The IMA link is receiving an Alarm Indication Signal.
RAI Received	Critical	The IMA link is receiving a remote alarm indication.
LCD	Critical	The IMA link is experiencing a loss of cell delineation.
LIF ¹	Critical	The IMA link is experiencing an LIF defect at the near end.
LODS ²	Critical	The link differential delay between the link and the other links in the group is over the tolerable value for link differential delay.
Rx Failed	Critical	A persistent detection of a defect at the receiver. The criteria for entering the condition are implementation specific.
Tx Link Misconnected	Critical	The Tx link is not connected to the same far end IMA unit as the other Tx links in the group. The detection is implementation specific.
Rx Link Misconnected	Critical	The Rx link is not connected to the same far end IMA unit as the other Rx links in the group. The detection is implementation specific.
Persistent NE ³ RDI-IMA	Critical	One of the available remote defect indicators (including IMA link specific defect) is in the link-related "Link Information" field.
Rx Fault	Critical	Implementation specific Rx fault declared at the near end.
Tx Fault	Critical	Implementation specific Tx fault declared at the near end.

Table 5-16 IMA Link Network Interface Alarms (continued)

Alarm	Severity	Description
Tx Link Unusable—FE ⁴	Critical	The far end is reporting that Tx is unusable.
Rx Link Unusable—FE	Critical	The far end is reporting that Rx is unusable.

1. LIF = loss of IMA frame
2. LODS = link out of delay sync
3. NE = near end
4. FE = far end

The source of the IMA group alarms in Table 5-17 is one of the following interfaces: ATM0/IMA0 through ATM0/IMA3.

Table 5-17 IMA Group Alarms

Alarm	Severity	Description
Start-up—FE	Critical	The far end is starting up. The declaration of this failure alarm might be delayed to ensure that the far end remains in startup.
Configuration Abort	Critical	The far end is trying to use unacceptable configuration parameters.
Configuration Abort—FE	Critical	The far end is reporting unacceptable configuration parameters.
Insufficient Links	Critical	Fewer than P _{Tx} transmit or P _{Rx} receive links are active.
Insufficient Links—FE	Critical	The far end is reporting that fewer than P _{Tx} transmit or P _{Rx} receive links are active.
Blocked—FE	Critical	The far end is reporting that it is blocked.
Timing Mismatch	Critical	The far end transmit clock mode is different from the near end transmit clock mode.

Table 5-18 describes NI-2 card redundancy alarms.

Table 5-18 NI-2 Card Redundancy Alarms

Alarm	Keyword	Severity	Description
Active/Standby NI2 type mismatch	C6100_CONTROLLER_SLOT_MISMATCH_ALARM	Major	The NI-2 cards installed in slot 10 and slot 11 are different types; for example, one is an OC-3c/OC-3c NI-2 card and the other is a DS3/2DS3 NI-2 card.
Standby NI2 missing	C6100_CONTROLLER_SLOT_MISSING_ALARM	Major	The secondary NI-2 card slot has been provisioned for a standby NI-2 card, but the card is not installed in the chassis.
Redundancy process failed	NI2_RF_PROCESS_FAILED	Major	An internal redundancy software process has failed and redundancy might not be available.

Table 5-18 NI-2 Card Redundancy Alarms (continued)

Alarm	Keyword	Severity	Description
Peer APS mode mismatch	APS_MODE_MISMATCH_ALARM	Minor	The OC-3 trunk is connected to a device not configured for nonrevertive, unidirectional APS.
Both units ACTIVE	NI2_RF_ACTIVE_CLASH	Info	Both the primary and the secondary NI-2 cards have come up in an active state.

Table 5-19 describes fan tray alarms.

Table 5-19 Fan Tray Alarms

Alarm	Severity	Description
Not detected or missing	Major	The fan tray has been removed from the chassis or is missing.
Multiple fan failures	Major	Two or more fan modules in the fan tray have failed. When fan modules fail, the remaining fan modules run at full speed until the fault is corrected.
Single fan failure	Minor	One of the three fans in the fan tray has failed. When fans fail, the remaining fans run at full speed until the fault is corrected.

Table 5-20 describes power alarms.

Table 5-20 Power Alarms

Alarm	Severity	Description
Input voltage out of range	Major	The input voltage to one or both PEMs is outside the acceptable range.
Excessive current	Major	The current flowing through one or both PEMs is too high.
Fan voltage out of range	Major	The voltage going to the fans from one or both PEMs is outside the acceptable range.
Power supply fault	Major	One or both PEMs are reporting a fault caused by high temperature, output failure, or input failure.
Temperature exceeds limit	Major	The PEM temperature is beyond the acceptable range.



Upgrading and Maintaining the Cisco 6260 System

This chapter describes upgrade and maintenance procedures for the Cisco 6260 system.

6.1 Backing Up Software

We recommend that you maintain, on a TFTP server, current copies of three files for each Cisco 6260 system:

- The Cisco IOS software image
- The configuration file (running-config)
- The bootflash file

If you keep copies of these files on a TFTP server, you can easily recover from a fault in an NI-2 card: simply replace the NI-2 card, and download the software image and configuration file from the TFTP server. Remember to update your backup files whenever you change your configuration or upgrade your Cisco IOS software.

Complete the following steps to copy the Cisco IOS software image and configuration file to a TFTP server:

-
- Step 1** Log in to the Cisco 6260 node whose software you wish to back up.
- Step 2** Enter the **dir** command to display the names of the files:
- ```
6260# dir
```
- Step 3** Enter a **copy** command to copy the IOS software file to the node TFTP server:
- ```
6260# copy bootflash:<image-name> tftp
```
- Step 4** Enter a second **copy** command to copy the configuration file to the node TFTP server:
- ```
6260# copy running-config tftp
```
-

## 6.2 Fan Tray Maintenance

The following sections describe the preventive maintenance procedures for the fan tray:

- Replacing or Cleaning the Air Filter
- Removing and Replacing the Fan Tray

### 6.2.1 Replacing or Cleaning the Air Filter

You must periodically clean or replace the two air filters in the Cisco 6260.

Once a month (or more often in dusty environments), examine the air filters and clean or replace them if they are dirty. Keep a log recording the date of each filter cleaning and filter replacement.

You can clean or replace the air filters while the Cisco 6260 remains powered up and fully operational. You can order a replacement air filter through Cisco.

The remainder of this section explains how to remove, clean, and replace the filters.

#### 6.2.1.1 Required Tools and Equipment

To clean the air filters, you need one of the following:

- Vacuum cleaner (preferred)
- Clean water
- Mild detergent, if the filter is very dirty

New air filters are the only parts you need if you decide that the old filters need replacing.



## 6.2.1.2 Removing an Air Filter

This procedure tells you how to remove an air filter from the Cisco 6260 chassis. Perform this procedure for each of the two air filters in each chassis.

- Step 1** Connect a grounding strap to the ESD grounding jack that is located on the top right of the Cisco 6260 card cage.
- Step 2** Using a Phillips-head screwdriver, loosen the screw and remove the metal bezel that covers the air filters. (See Figure 6-1.)

**Figure 6-1** Removing the Bezel and Air Filters

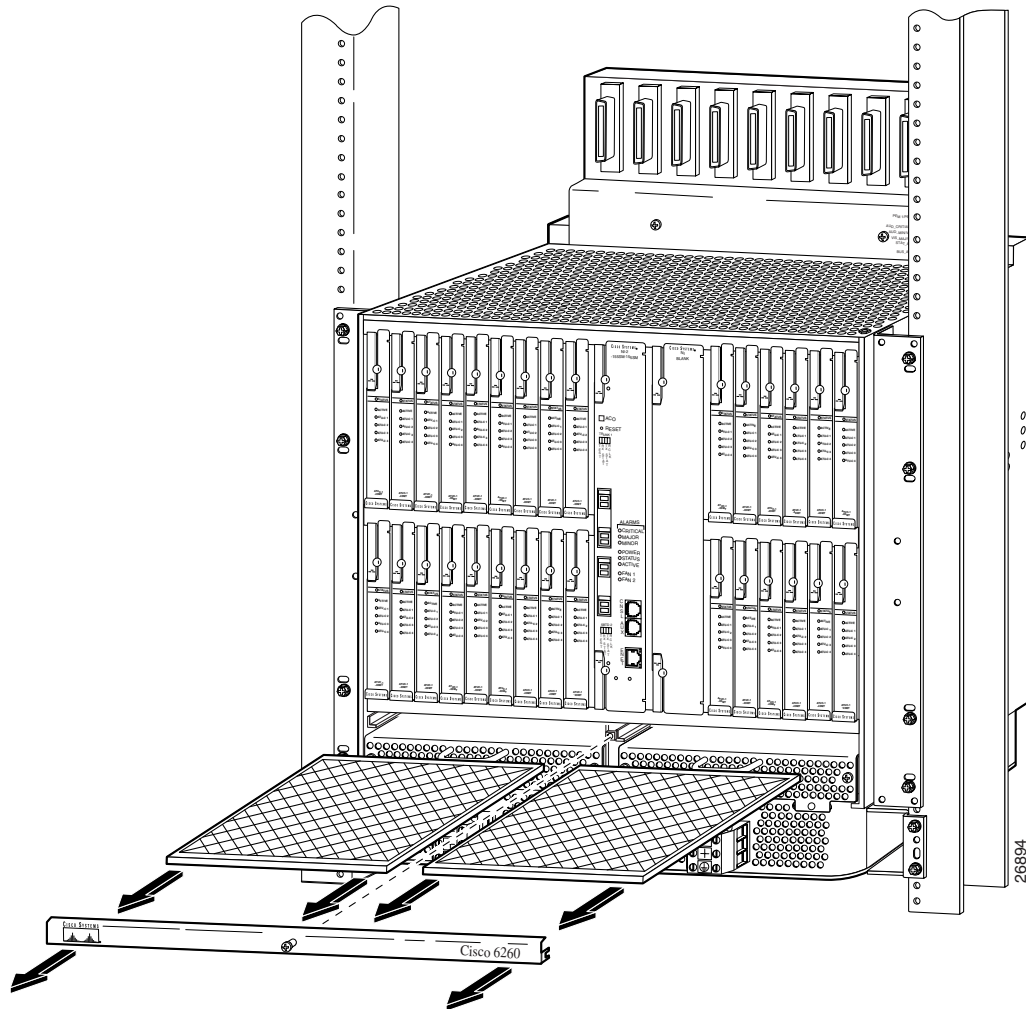

- Step 3** The air filter slides out from the top of the fan tray. Gently pull the filter toward you to remove it from the tray.
- Step 4** If you are replacing the air filter, discard it and go to the “Replacing the Air Filter” section on page 6-4.
- Step 5** If you wish to clean the air filter, go to the “Cleaning the Air Filter” section on page 6-4.

### 6.2.1.3 Cleaning the Air Filter

This section tells you how to clean a Cisco 6260 air filter. Go to the “Replacing the Air Filter” section on page 6-4 if you are replacing an old filter with a new one.

Use one of the following methods to clean the air filter:

- Vacuum. Vacuum cleaning is preferred because you need not dry the filter afterwards. Vacuum the filter until it is clean and free of dust.
- Clean with plain water. Placing the filter under a stream of plain water is equally effective. Hold the filter under the water with the metal grill facing up and let the water flow down through the filter. (This orientation causes the water to flow through the filter in the direction opposite from the usual air flow, so you dislodge rather than embed matter trapped in the filter.) Allow the filter to dry thoroughly before reinstalling it.
- Clean with hot water and mild detergent. If the filter is too dirty to be completely cleaned with a vacuum or with plain water, immerse the filter in a solution of hot water and mild detergent. Rinse the filter thoroughly in clear water and allow it to dry completely before reinstalling it.

### 6.2.1.4 Replacing the Air Filter

Use these steps to replace the air filter:

- 
- Step 1** Hold the air filter so that
- The side with the metal grill is facing up.
  - One of the long sides goes in first.
- Step 2** Slide the filter into its slot above the fan tray.
- Step 3** Replace the bezel that covers the fan tray and tighten the screw using a Phillips-head screwdriver to secure the bezel.
- 

## 6.2.2 Removing and Replacing the Fan Tray

If the fans are running too slowly or are no longer operational, the system management software generates an alarm. You will need to replace the nonoperational fan tray. While you are replacing the nonoperational fan tray, the operational fan tray continues to run. You can order a replacement fan tray through Cisco.

The compartments for the two fan trays are located side by side near the bottom of the chassis, just above the PEMs. A narrow bezel fits across the chassis to hold the air filters and fan trays in place (see Figure 6-2).

You need a Number 2 Phillips-head screwdriver to remove and replace the bezel and to tighten the screws that secure the fan tray to the chassis.

**Note**

You need not turn off the power before removing a fan tray. However, if you must remove a fan tray from an operating Cisco 6260, replace it within 5 minutes. If that is not possible, shut the system down and turn off the power to avoid thermal damage.

---

  
Warning

If you do not have a replacement fan tray available, pull all of the line cards away from the backplane connection and power off the system until a replacement fan tray is available.

  
Caution

The cooling fans in both fan trays must run while the system is powered up. The system could suffer thermal damage if the fans in either tray stop for more than 5 minutes.

Figure 6-2 Close-up View of Cisco 6260 Chassis with Fan Trays and Bezel

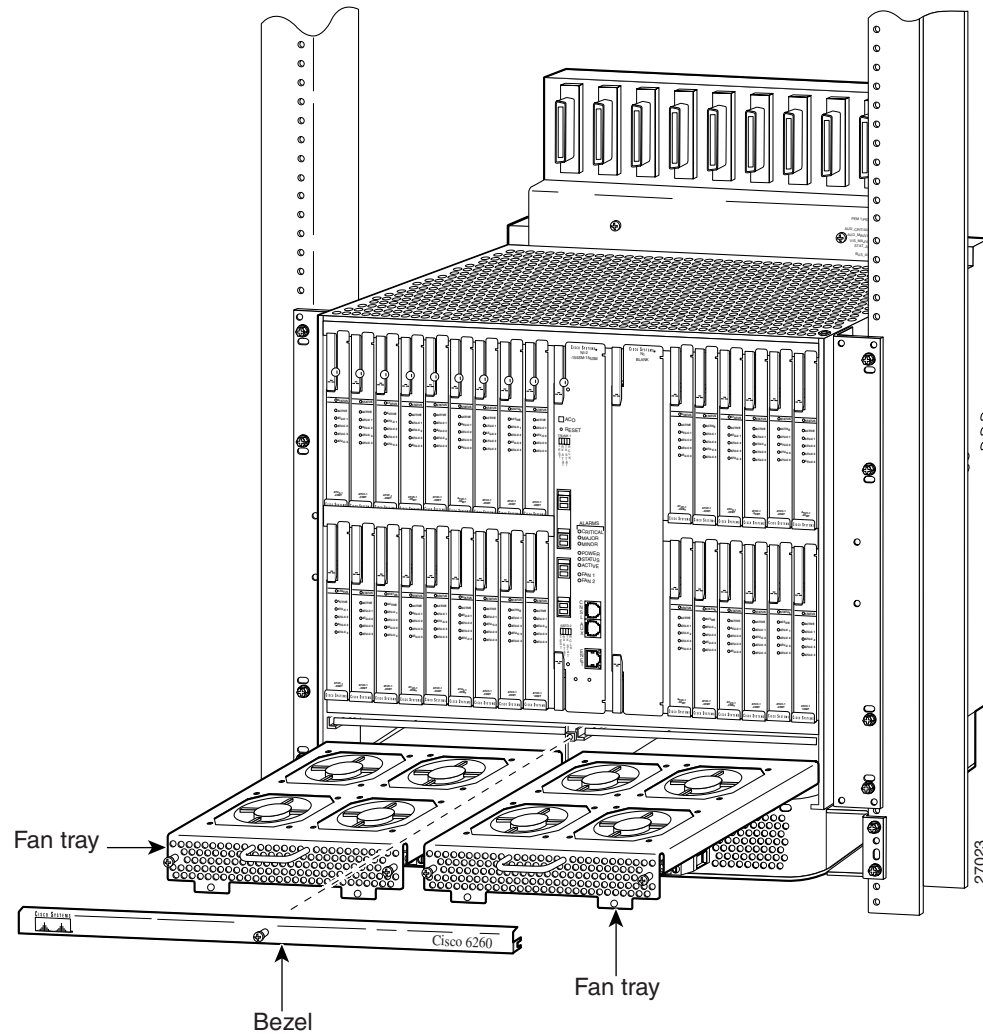

Complete these steps to remove and replace a fan tray in the Cisco 6260:

- Step 1** Connect a grounding strap to the ESD grounding jack located on the top right of the Cisco 6260 card cage.
- Step 2** Use a Phillips-head screwdriver to loosen the screw to remove the bezel that partially covers the fan trays.

- Step 3** Use a Phillips-head screwdriver to loosen the two screws on the fan tray.
- Step 4** Grasp the fan tray by the handle and pull it from the chassis. If the fans are running, you will hear them slow down as the tray disengages from its power connector.

**Warning**

---

**The fans continue to turn at high speed for several seconds after the fan tray is removed from the chassis. To avoid injury to your hands, touch the fan tray only by its handle until the fans have stopped.**

---

**Note**

---

If there is a second fan tray in the chassis, you will hear it speed up when you remove the first fan tray.

---

- Step 5** Insert the replacement fan tray into the chassis. Make sure that the pins in the lower lip of the fan tray front panel engage with the holes in the PEM below.
- Step 6** Press the fan tray firmly into its slot to ensure that the power connectors mate. If the power is on, you will hear the fans start to turn. The fault light for the fan tray you are installing will stay on until the fans reach full speed, which takes several seconds. (Fan fault LEDs are Fan Tray 1 and Fan Tray 2 on the PEM.)

**Note**

---

When you insert a fan tray, you might hear the fans in the other fan tray slow down; this is normal.

---

- Step 7** Use the Phillips-head screwdriver to tighten the two fasteners on the fan tray.

- Step 8** Use the Phillips-head screwdriver to replace the bezel.
- 

## 6.3 Installing and Replacing Hardware

The following sections detail the installation and removal procedures for the following field replaceable unit (FRU) hardware components:

- xTU-C line card
- DS3/2DS3 (E3/E3) NI-2 card
- DS3+T1/E1 IMA NI-2 card
- OC-3c/OC-3c NI-2 card

**Note**

---

See the “Installation and Replacement Suggestions” section on page 2-11 for examples of recommended card installation and replacement practices.

---

**Caution**

---

Proper ESD protection is required whenever you handle Cisco digital subscriber line access multiplexer (DSLAM) equipment. Installation and maintenance personnel should be properly grounded by means of ground straps to eliminate the risk of ESD damage to the equipment. Cards are subject to ESD damage whenever they are removed from the chassis.

---

## 6.3.1 xTU-C Line Card

The following sections describe how to remove and replace or install an xTU-C line card.

### 6.3.1.1 Installing an xTU-C Line Card

Complete the following steps to install the xTU-C line card in the chassis.

**Note**

---

It is important that you complete each step before moving on to the next step.

---

- Step 1** Connect a grounding strap to the ESD grounding jack that is located on the top right of the Cisco 6260 card cage.
- Step 2** Hold the xTU-C line card vertically, with the line card faceplate toward you and the connectors facing the chassis slot.
- Step 3** Align the upper and lower edges of the xTU-C line card with the upper and lower guides in the chassis slot.
- Step 4** Lift up on the ejector lever and gently apply pressure to the bottom of the faceplate while pushing the line card into the slot.

Figure 6-3 shows the line card installation for a Cisco 6260 chassis.

**Figure 6-3** xTU-C Line Card Installation

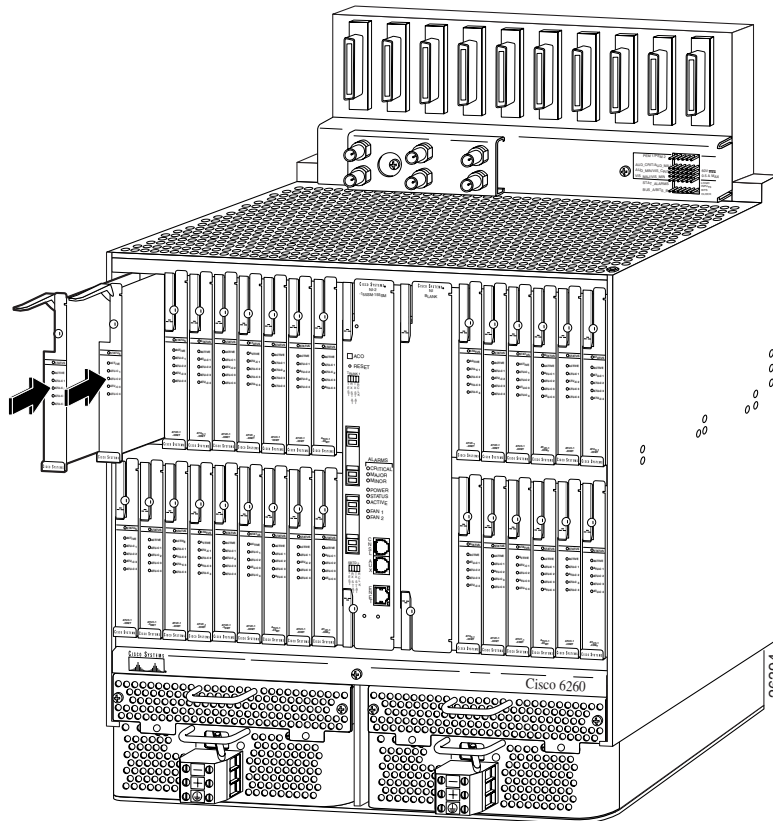

- Step 5** Push on the faceplate of each line card to fully seat the line card.
- Step 6** Press down on the ejector lever to secure the line card and connect it to the backplane.
- Step 7** Use a flat-head screwdriver to turn the locking tab so that it overlaps the xTU-C line card to prevent inadvertent dislodging. Figure 6-4 shows how to position the locking tab.

**Figure 6-4** Positioning the Locking Tab for the xTU-C Line Card Installation and Removal

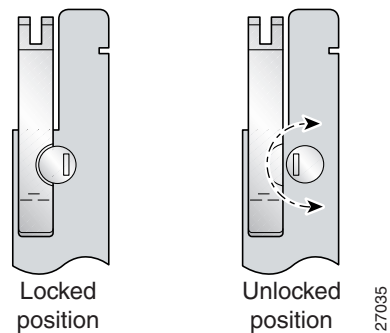

**Note** It is not necessary to lock the xTU-C line cards in the Cisco 6260 chassis.

- Step 8** Verify that the STATUS LED is solid green after the brief self-test. If the STATUS LED is not green after the self-test, see Chapter 5, “Troubleshooting,” for troubleshooting procedures.



**Note** If you are installing the line card for the first time, refer to the provisioning procedures in the appropriate software guide for your chassis.

### 6.3.1.2 Removing an xTU-C Line Card

Complete the following steps to remove a xTU-C line card from the chassis:

- Step 1** Connect a grounding strap to the ESD grounding jack that is located on the top right of the Cisco 6260 card cage.
- Step 2** Use a flat-head screwdriver to move the locking tab from the locked to the unlocked position. Be sure to turn the locking tab so that it does not overlap the xTU-C line card ejector lever, as shown in Figure 6-4.
- Step 3** Lift up on the ejector lever. This action disconnects the line card from the backplane.
- Step 4** Carefully slide the line card out of the slot.
- Step 5** Either replace the line card that you remove, or insert a blank faceplate in the empty slot. See the “Installing an xTU-C Line Card” section on page 6-7 for installation instructions for xTU-C line cards. For blank faceplate installation instructions, see the appropriate installation chapter for your configuration.



**Note** Blank faceplates should occupy any empty slots in the chassis.

### 6.3.2 DS3/2DS3 NI-2 Card

The following sections describe how to remove and replace or install a DS3/2DS3 NI-2 card.



**Warning**

**The ports labeled "ENET," "CNSL," and "AUX" are SELV circuits. SELV circuits should be connected only to other SELV circuits. Because the DSL circuits are treated like telephone-network voltage, avoid connecting the SELV circuit to the TNV circuits.**



**Tip**

We recommend that you label each data cable at both ends to identify its destination.

**Caution**

Service is interrupted to the entire system when the NI-2 card is removed unless a secondary NI-2 card is installed in the chassis. If a secondary NI-2 card is not installed, ensure that a service interruption is acceptable before proceeding.

If a secondary NI-2 card is installed in the chassis, removing the active NI-2 card causes a switchover to the standby NI-2 card, which interrupts data traffic for approximately 60 seconds.

Removing a standby NI-2 card does not interrupt service to the system.

**Caution**

Proper ESD protection is required each time you handle Cisco DSLAM equipment. Installation and maintenance personnel should be properly grounded by means of ground straps to eliminate the risk of ESD damage to the equipment. Cards are subject to ESD damage each time they are removed from the chassis.

**Caution**

Installing the cards in the chassis with the power leads reversed can damage the cards.

**Warning**

**The power supply circuitry for the Cisco DSLAM equipment can constitute an energy hazard. Before you install or replace the equipment, remove all jewelry (including rings, necklaces, and watches). Metal objects can come into contact with exposed power supply wiring or circuitry inside the DSLAM equipment. This could cause the metal objects to heat up and cause serious burns or weld the metal object to the equipment.**

**Warning**

**Do not reach into a vacant slot or chassis while you install or remove a line card or a fan. Exposed circuitry could constitute an energy hazard.**

**Note**

All cards must be fully seated in the chassis. A push on the faceplate of each card is required for the card to be fully seated.

### 6.3.2.1 Installing a DS3/2DS3 NI-2 Card

Complete the following steps to install a DS3/2DS3 NI-2 card in the chassis. It is important to complete each step before moving on to the next step.

- Step 1** Connect a grounding strap to the ESD grounding jack that is located on the top right of the Cisco 6260 card cage.
- Step 2** Inspect the NI-2 card. Verify that the daughterboard is fully seated on the main board.
- Step 3** Verify that slots 10 and 11 of the Cisco 6260 chassis have no bent pins.
- Step 4** Vertically align the card edge with the card guides at the top and bottom of slot 10 or slot 11 in the chassis.

Figure 6-5 shows the NI-2 card installation for a Cisco 6260 chassis. The basic installation procedures are the same for all NI-2 card types.

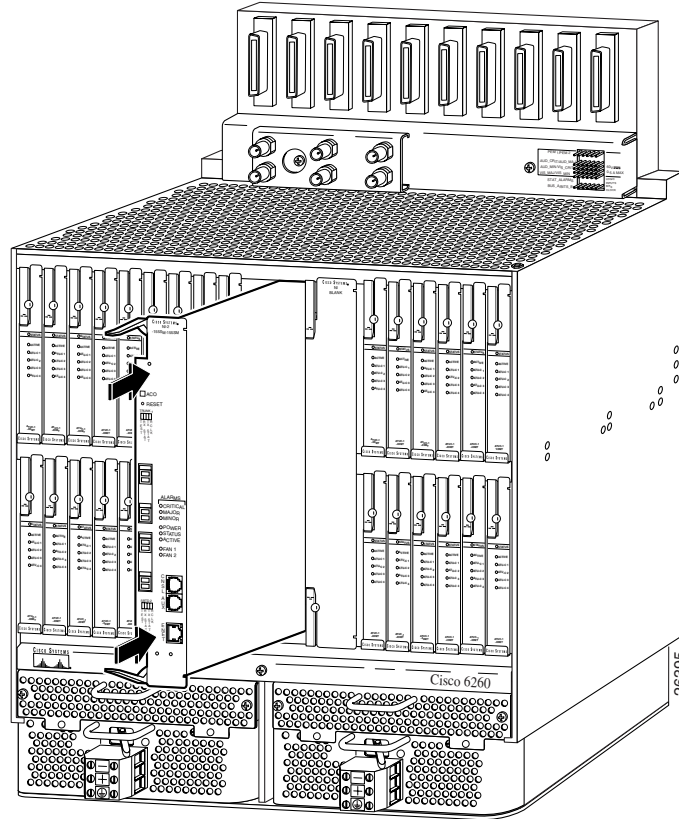

**Figure 6-5 NI-2 Card Installation**

- Step 5** Lift up on the ejector levers and gently apply pressure to the bottom of the faceplate while pushing the card into the slot.
- Step 6** Push on the faceplate of the card to fully seat the card.
- Step 7** Press down on the ejector levers to secure the card and connect it to the backplane.
- Step 8** Use a flat-head screwdriver to turn the locking tabs on the faceplate so that they overlap the NI-2 card ejector levers to prevent inadvertent dislodging, as shown in Figure 6-6.

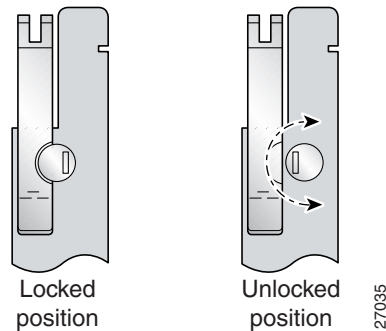
**Figure 6-6 Positioning the Locking Tab for NI-2 Card Removal and Installation**

- Step 9** Verify that the STATUS, ACTIVE, and POWER LEDs on the NI-2 card are solid green after the self-test is complete. This self-test procedure takes several minutes. If the STATUS LEDs are not green after the self-test, see Chapter 5, “Troubleshooting,” for troubleshooting procedures.

**Step 10** Perform a software update if the STATUS LED on the NI-2 card is flashing.



**Note** If you are installing the card for the first time, refer to the provisioning procedures in the appropriate software guide for your chassis.

The network connection to the ATM switch and the subtending connections are made from the I/O module. For more information on these connection procedures, see the installation chapter in this guide that corresponds to your configuration.

**Step 11** Connect the Ethernet to the management network.

**Step 12** Connect a VT100-compatible terminal to the NI-2 card CNSL connector.

**Step 13** Connect a terminal, a modem, or another serial device to the NI-2 RJ-45 AUX.



**Note** See the appropriate installation chapter in this guide for connection procedures for the ENET, CNSL, and AUX ports.

### 6.3.2.2 Removing a DS3/2DS3 NI-2 Card

Complete the following steps to remove a DS3/2DS3 NI-2 card from the chassis. It is important that you complete each step before moving on to the next step.

**Step 1** Connect a grounding strap to the ESD grounding jack that is located on the top right of the Cisco 6260 chassis.

**Step 2** Disconnect the cable connected to the AUX receptacle on the NI-2 card, if necessary.

**Step 3** Disconnect the cable connected to the CNSL receptacle on the NI-2 card, if necessary.

**Step 4** Disconnect the cable connected to the ENET receptacle on the NI-2 card, if necessary.

**Step 5** Use a flat-head screwdriver to move the locking tabs from the locked to the unlocked position. Be sure to turn the locking tabs so that they do not overlap the card, as shown in Figure 6-6.

**Step 6** Lift up on the NI-2 card ejector tabs. This action disconnects the card from the backplane.

**Step 7** Carefully slide the card out of the slot.

See the “Installing a DS3/2DS3 NI-2 Card” section on page 6-10 for NI-2 card installation procedures.



**Note** The network connection to the ATM switch and the subtending connections are made from the I/O module. For more information on these connection procedures, see the installation chapter in this guide that corresponds to your configuration.

### 6.3.3 DS3+T1/E1 IMA NI-2 Card

The following sections describe how to remove and replace or install a DS3+T1/E1 IMA NI-2 card.

**Warning**

The ports labeled "ENET," "CNSL," and "AUX" are SELV circuits. SELV circuits should be connected only to other SELV circuits. Because the DSL circuits are treated like telephone-network voltage, avoid connecting the SELV circuit to the TNV circuits.

**Tip**

We recommend that you label each data cable at both ends to identify its destination.

**Caution**

Proper ESD protection is required each time you handle Cisco DSLAM equipment. Installation and maintenance personnel should be properly grounded by means of ground straps to eliminate the risk of ESD damage to the equipment. Cards are subject to ESD damage each time they are removed from the chassis.

**Caution**

Installing the cards in the chassis with the power leads reversed can damage the cards.

**Warning**

The power supply circuitry for the Cisco DSLAM equipment can constitute an energy hazard. Before you install or replace the equipment, remove all jewelry (including rings, necklaces, and watches). Metal objects can come into contact with exposed power supply wiring or circuitry inside the DSLAM equipment. This could cause the metal objects to heat up and cause serious burns or weld the metal object to the equipment.

**Warning**

Do not reach into a vacant slot or chassis while you install or remove a line card or a fan. Exposed circuitry could constitute an energy hazard.

**Note**

All cards must be fully seated in the chassis. A push on the faceplate of each card is required for the card to be fully seated.

### 6.3.3.1 Installing a DS3+T1/E1 IMA NI-2 Card

Complete the following steps to install a DS3+T1/E1 IMA NI-2 card in the chassis. It is important that you complete each step before moving on to the next step.

**Note**

All cards must be fully seated in the chassis. A push on the faceplate of each card is required for the card to be fully seated.

- Step 1** Connect a grounding strap to the ESD grounding jack that is located on the top right of the Cisco 6260 card cage.
- Step 2** Inspect the NI-2 card. Verify that the daughterboard is fully seated on the main board.
- Step 3** Verify that the NI-2 card slot in the chassis has no bent pins.
- Step 4** Hold the NI-2 card with the faceplate toward you and the connectors facing the chassis slot.

- Step 5** Align the card edge with the slot guides in the chassis.
- Step 6** Lift up on the ejector levers and gently apply pressure to the faceplate while pushing the card into the slot.
- Step 7** Push on the faceplate of the card to fully seat the card.
- Step 8** Press down on the ejector levers to secure the card and connect it to the backplane.
- Step 9** Use a flat-head screwdriver to turn the locking tabs on the faceplate so that they overlap the NI-2 card ejector levers to prevent inadvertent dislodging. Figure 6-6 shows how to position the locking tabs.
- Step 10** Verify that the STATUS, ACTIVE, and POWER LEDs on the NI-2 card are solid green after the self-test is complete. This self-test procedure takes several minutes. If the LEDs are not green after the self-test, refer to Chapter 5, “Troubleshooting” for troubleshooting procedures.



---

**Note** If you are installing the card for the first time, refer to the provisioning procedures in the appropriate software guide for your chassis.

---

- Step 11** Perform a software update if the STATUS LED on the NI-2 card is flashing. Refer to the appropriate software guide for your chassis for software upgrade procedures.



---

**Note** The network connection to the ATM switch and the subtending connections are made from the I/O module. For more information on these connection procedures, see the installation chapter in this guide that corresponds to your configuration.

---

- Step 12** Connect the Ethernet to the management network.
- Step 13** Connect a VT100-compatible terminal to the NI-2 card CNSL connector.
- Step 14** Connect a terminal, a modem, or another serial device to the NI-2 RJ-45 AUX.



---

**Note** See the appropriate installation chapter in this guide for connection procedures for the ENET, CNSL, and AUX ports.

---

### 6.3.3.2 Removing a DS3+T1/E1 IMA NI-2 Card

Complete the following steps to remove a DS3+T1/E1 IMA NI-2 card from the chassis. It is important that you complete each step before moving on to the next step.



---

**Caution** Service is interrupted to the entire system when the NI-2 card is removed. Before removing the NI-2 card, ensure that a service interruption is acceptable.

---

- Step 1** Connect a grounding strap to the ESD grounding jack that is located on the top right of the Cisco 6260 chassis.
- Step 2** Disconnect the cable connected to the AUX receptacle on the NI-2 card, if necessary.
- Step 3** Disconnect the cable connected to the CNSL receptacle on the NI-2 card, if necessary.
- Step 4** Disconnect the cable connected to the ENET receptacle on the NI-2 card, if necessary.

- Step 5** Use a flat-head screwdriver to move the locking tabs on the faceplate from the locked to the unlocked position. Be sure to turn the locking tabs so that they do not overlap the NI-2 card ejector levers, as shown in Figure 6-6.
- Step 6** Lift up on the ejector levers. This action disconnects the card from the backplane.
- Step 7** Carefully slide the card out of the slot.
- See the “Installing a DS3+T1/E1 IMA NI-2 Card” section on page 6-13 for NI-2 card installation procedures.

## 6.3.4 OC-3c/OC-3c NI-2 Card

The following sections describe how to remove and replace or install an OC-3c/OC-3c NI-2 card.



### Warning

**The ports labeled "ENET," "CNLSL," and "AUX" are SELV circuits. SELV circuits should be connected only to other SELV circuits. Because the DSL circuits are treated like telephone-network voltage, avoid connecting the SELV circuit to the TNV circuits.**



### Timesaver

We recommend that you label each data cable at both ends to identify its destination.



### Caution

Service is interrupted to the entire system when the NI-2 card is removed unless a secondary NI-2 card is installed in the chassis. If a secondary NI-2 card is not installed, ensure that a service interruption is acceptable before proceeding.

If a secondary NI-2 card is installed in the chassis, removing the active NI-2 card causes a switchover to the standby NI-2 card, which interrupts data traffic for approximately 60 seconds.

Removing a standby NI-2 card does not interrupt service to the system.



### Caution

Proper ESD protection is required each time you handle Cisco DSLAM equipment. Installation and maintenance personnel should be properly grounded by means of ground straps to eliminate the risk of ESD damage to the equipment. Cards are subject to ESD damage each time they are removed from the chassis.



### Caution

Installing the cards in the chassis with the power leads reversed can damage the cards.



### Warning

**The power supply circuitry for the Cisco DSLAM equipment can constitute an energy hazard. Before you install or replace the equipment, remove all jewelry (including rings, necklaces, and watches). Metal objects can come into contact with exposed power supply wiring or circuitry inside the DSLAM equipment. This could cause the metal objects to heat up and cause serious burns or weld the metal object to the equipment.**

**Warning**

---

**Do not reach into a vacant slot or chassis while you install or remove a line card or a fan. Exposed circuitry could constitute an energy hazard.**

---

**Warning**

---

**Do not stare into the beam or view it directly with optical instruments.**

---

**Note**

---

All cards must be fully seated in the chassis. A push on the faceplate of each card is required for the card to be fully seated.

---

### 6.3.4.1 Installing an OC-3c/OC-3c NI-2 Card

Complete the following steps to install an OC-3c/OC-3c NI-2 card in the chassis. It is important that you complete each step before moving on to the next step.

- 
- Step 1** Connect a grounding strap to the ESD grounding jack that is located on the top right of the Cisco 6260 card cage.
  - Step 2** Inspect the NI-2 card. Verify that the daughterboard is fully seated on the main board.
  - Step 3** Verify that slots 10 and 11 of the chassis have no bent pins.
  - Step 4** Vertically align the card edge with the card guides at the top and bottom of slot 10 in the chassis. Figure 6-5 shows the NI-2 installation in a Cisco 6260 chassis.
  - Step 5** Lift up on the ejector levers and gently apply pressure to the bottom of the faceplate while pushing the card into the slot.
  - Step 6** Push on the faceplate of each card to fully seat the card.
  - Step 7** Press down on the ejector levers to secure the card and connect it to the backplane.
  - Step 8** Use a flat-head screwdriver to turn the locking tab so that it overlaps the NI-2 card to prevent inadvertent dislodging, as shown in Figure 6-6.
  - Step 9** Verify that the STATUS, ACTIVE, and POWER LEDs on the NI-2 card are solid green after the self-test is complete. This self-test procedure takes several minutes. If the STATUS LEDs are not green after the self-test, see Chapter 5, “Troubleshooting,” for troubleshooting procedures.
  - Step 10** Perform a software update if the STATUS LED on the NI-2 card is flashing. Refer to the appropriate software guide for your chassis for software upgrade procedures.
  - Step 11** Attach the RX cable from the ATM switch to the TRNK 1 TX connector in the inset on the NI-2 card. See Figure 1-18 for the OC-3c network interface connection location.
  - Step 12** Attach the TX cable from the ATM switch to the TRNK 1 RX connector in the inset on the NI-2 card. See Figure 1-18 for the OC-3c network interface connection location.

**Note**

---

To cable the chassis for OC-3c subtending, see the installation chapter in this guide that corresponds to your configuration.

---

- Step 13** Connect the Ethernet to the management network.
- Step 14** Connect a VT100-compatible terminal to the NI-2 card CNSL connector.

**Step 15** Connect a terminal, a modem, or another serial device to the NI-2 RJ-45 AUX.



**Note** See the appropriate installation chapter in this guide for connection procedures for the ENET, CNSL, and AUX ports.

**Step 16** To connect your system for APS link redundancy, repeat Step 2 through Step 12 for slot 11.

### 6.3.4.2 Removing an OC-3c/OC-3c NI-2 Card

Complete the following steps to remove an OC-3c/OC-3c NI-2 card from the chassis. It is important that you complete each step before moving on to the next step.

- Step 1** Connect a grounding strap to the ESD grounding jack that is located on the top right of the Cisco 6260 card cage.
- Step 2** Disconnect the cable connected to the AUX port on the NI-2 card, if necessary.
- Step 3** Disconnect the cable connected to the CNSL port on the NI-2 card, if necessary.
- Step 4** Disconnect the cable connected to the ENET port on the NI-2 card, if necessary.
- Step 5** Disconnect the cable from the TRNK 1 TX connector on the NI-2 card, if necessary.
- Step 6** Disconnect the cable from the TRNK 1 RX connector on the NI-2 card, if necessary.
- Step 7** Disconnect the cable from the SBTD 2 RX connector on the NI-2 card, if necessary.
- Step 8** Disconnect the cable from the SBTD 2 RX connector on the NI-2 card, if necessary.
- Step 9** Use a flat-head screwdriver to move the locking tabs on the NI-2 card faceplate from the locked to the unlocked position. Be sure to turn the locking tabs so that they do not overlap the NI-2 card ejector levers, as shown in Figure 6-6.
- Step 10** Lift up on the ejector levers. This action disconnects the card from the backplane.
- Step 11** Carefully slide the card out of the slot.

See the “Installing an OC-3c/OC-3c NI-2 Card” section on page 6-16 for NI-2 card installation procedures.

## 6.3.5 I/O Module

The following sections describe how to install or remove an E3, E1, or OC-3c I/O module.



### Caution

Proper ESD protection is required whenever you handle Cisco DSLAM equipment. Installation and maintenance personnel should be properly grounded by means of ground straps to eliminate the risk of ESD damage to the equipment. Modules are subject to ESD damage whenever they are removed from the chassis.

**Warning**

The ports labeled “CNSL,” “AUX,” “ENET,” “Tx,” and “Rx (DS3)” are safety extra-low voltage (SELV) circuits. SELV circuits should only be connected to other SELV circuits. Because the Basic Rate Interface (BRI) circuits are treated like telephone-network voltage (TNV), avoid connecting the SELV circuit to the TNV circuits.

**Warning**

This equipment is to be installed and maintained by service personnel only as defined by AS/NZS 3260 Clause 1.2.14.3 Service Personnel.

**Warning**

This product requires short-circuit (overcurrent) protection, to be provided as part of the building installation. Install only in accordance with national and local wiring regulations.

**Warning**

The telecommunications lines must be disconnected 1) before unplugging the main power connector or 2) while the housing is open.

**Warning**

VCCI Compliance for Class B Equipment (Japan).

This is a Class B product based on the standard of the Voluntary Control Council for Interference from Information Technology Equipment (VCCI). If this is used near a radio or television receiver in a domestic environment, it may cause radio interference. Install and use the equipment according to the instruction manual.

**Warning**

Hazardous network voltages are present in WAN ports regardless of whether power to the router is OFF or ON. To avoid electric shock, use caution when working near WAN ports. When detaching cables, detach the end away from the router first.

**Warning**

Metal objects heat up when connected to power and ground, and can cause serious burns.

**Caution**

Any module that is only partially connected to the backplane can disrupt system operation.

### 6.3.5.1 Installing an I/O Module

Complete the following steps to install and cable the I/O module on the Cisco 6260 chassis.

**Tip**

We recommend that you label each cable and wire at both ends to identify its destination.

**Step 1**

Connect a grounding strap to the ESD grounding jack that is located on the top right of the Cisco 6260 card cage.

**Step 2**

Use a Phillips-head screwdriver to remove the I/O module retaining screws.



- Step 3** Carefully align the I/O module with the Cisco 6260 backplane connectors on the upper front side of the chassis.
- Step 4** Hold the I/O module vertically and align the holes on the I/O module over the two retaining screws.
- Step 5** Carefully press the I/O module onto the Cisco 6260 connectors on the chassis backplane until the I/O module is seated fully.
- Step 6** Use a Phillips-head screwdriver and two retaining screws to attach the I/O module to the chassis.
- Step 7** Connect the E3 trunk if you are installing an E3 I/O module. See the installation chapter in this guide that corresponds to your configuration for E3 trunk and subtend connection procedures.
- Step 8** Connect the E1 trunk if you are installing an E1 I/O module. See the installation chapter in this guide that corresponds to your configuration for E3 trunk and subtend connection procedures.



---

**Note** The next step is optional.

---

- Step 9** Connect the external alarm device and BITS clock to the wire-wrap pins on the I/O module at the top of the chassis. See the installation chapter in this guide that corresponds to your configuration for alarm and BITS clock connection procedures.
- 

### 6.3.5.2 Removing an I/O Module

Complete the following steps to remove the I/O module from the Cisco 6260 chassis.



---

**Note** It is not necessary to power off the Cisco 6260 system to remove and replace the I/O module.

---



**Timesaver**

---

We recommend that you label each cable and wire at both ends to identify its destination.

---

- Step 1** Connect a grounding strap to the ESD grounding jack that is located on the top right of the Cisco 6260 card cage.
- Step 2** Disconnect the E3 BNC connectors from P1, P2, and P3 on the E3 I/O module, if applicable.
- Step 3** Disconnect the T1/E1 RJ-45 cables from the RJ-48 receptacle connectors on the E1 I/O module, if applicable.
- Step 4** Remove all wire-wrap pin connections from the I/O module.
- Step 5** Locate the two retaining screws on the faceplate of the I/O module that secure it to the Cisco 6260 chassis (Figure 6-7).

Figure 6-7 I/O Interface Module Retaining Screws

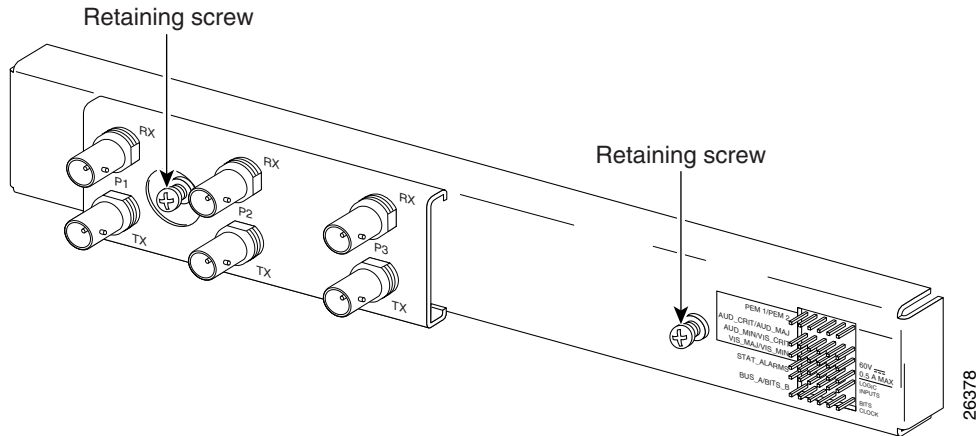

- Step 6** Use a Phillips-head screwdriver to remove the I/O module retaining screws.
- Step 7** Remove the I/O module from the chassis by carefully pulling the module horizontally away from the chassis.
- See the “Installing an I/O Module” section on page 6-18 for I/O module installation procedures.

## 6.3.6 PEM

The following sections describe how to install or remove a PEM.



### Caution

Proper ESD protection is required whenever you handle Cisco DSLAM equipment. Installation and maintenance personnel should be properly grounded by means of ground straps to eliminate the risk of ESD damage to the equipment. Modules are subject to ESD damage whenever they are removed from the chassis.

### 6.3.6.1 Installing the PEM

Complete the following steps to install or replace the DC PEM in the Cisco 6260 chassis.



**Note** Connect each Cisco 6260 PEM to a separate fuse. Do not power the components in the rack by chaining them together.

- Step 1** Connect a grounding strap to the ESD grounding jack that is located on the top right of the Cisco 6260 card cage.
- Step 2** Verify that the circuit breaker on the PEM is turned to the OFF (0) position, and that the PEM is disconnected from the fuse and alarm panel.
- Step 3** Verify that the fan tray above the PEM you wish to install is removed.
- Step 4** Horizontally align the module edge with the module guides at the right and left of the slot in the Cisco 6260.

Figure 6-8 depicts the PEM installation.

**Figure 6-8** PEM Installation

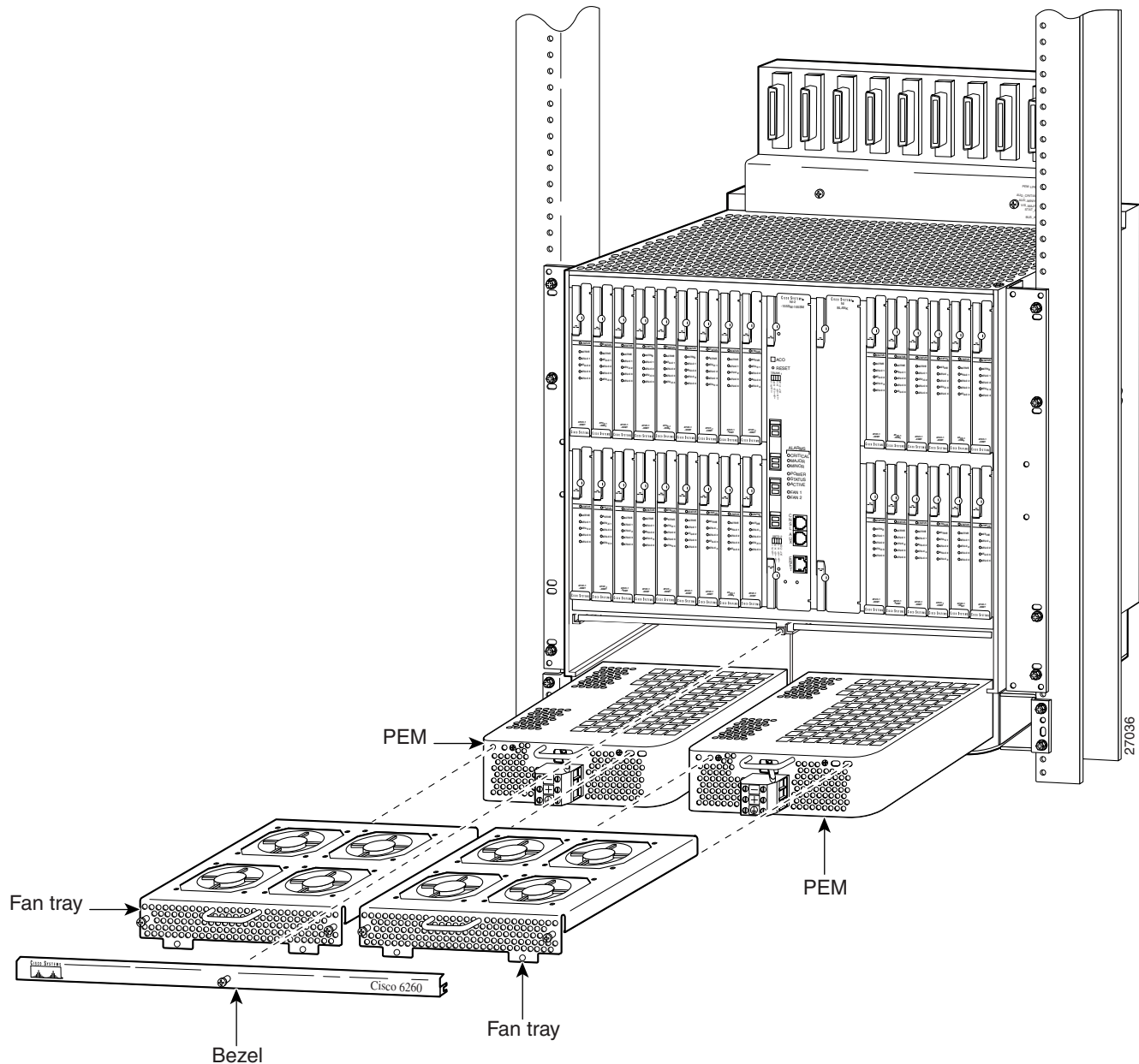

- Step 5** Hold the extraction handle on the front of the module and gently apply pressure while carefully pushing the module into the slot.



**Note** Forcefully inserting the PEM in the slot could cause damage to the EMI gasket located on the top of the faceplate.

- Step 6** Insert the fan tray into the compartment above the PEM. Make sure that the pins in the lower lip of the fan tray front panel engage with the holes in the PEM below.

- Step 7** Press the fan tray firmly into its slot to ensure that the power connectors mate.
- Step 8** Use a Phillips-head screwdriver to attach the two screws to the Cisco 6260 chassis.
- Step 9** Replace the bezel that covers the air filters.
- Step 10** Use a Phillips-head screwdriver to tighten the screws on the bezel and on the fan tray.

**Warning**

---

**When you are installing the unit, the ground connection must always be made first and disconnected last.**

---

- Step 11** Make the ground and power and connections to the PEM. See the installation chapter in this guide that corresponds to your configuration for PEM ground and power connection procedures.
- 

### 6.3.6.2 Removing the PEM

Complete the following steps to remove the PEM from the Cisco 6260 chassis:

- 
- Step 1** Connect a grounding strap to the ESD grounding jack that is located on the top right of the Cisco 6260 card cage.
  - Step 2** Turn the circuit breaker on the PEM to the OFF (0) position.
  - Step 3** Remove the fuses from the fuse and alarm panel.
  - Step 4** Disconnect the wires coming from the fuse and alarm panel to the PEM.
  - Step 5** Disconnect the grounding wire from the PEM.
  - Step 6** If a fan tray is present directly above the PEM you wish to remove, use the following steps to remove the fan tray first:
    - a.** Use a Phillips-head screwdriver to remove the bezel that partially covers the fan trays.
    - b.** Use a Phillips-head screwdriver to loosen the screws that hold the fan tray in place.
    - c.** Grasp the fan tray by the handle and pull it away from the chassis. If the fans are running, you will hear them slow down as the tray disengages from its power connector. Wait for the fans to stop before completely removing the tray.
  - Step 7** Use a Phillips-head screwdriver to unscrew the two screws and prepare to disconnect the PEM from the Cisco 6260 chassis.
  - Step 8** Hold the extraction handle on the front of the module and carefully slide the module out of the slot.
-



## Technical Specifications

---

This appendix provides the technical specifications for the Cisco 6260 system. The appendix contains the following sections:

- Hardware Specifications, page A-1
- Software Specifications, page A-12

### A.1 Hardware Specifications

This section details the specifications for the following hardware components:

- Cisco 6260 chassis
- Quad-port DMT ATU-C line card (4xDMT)
- Quad-port DMT over ISDN line card (4xDMT over ISDN)
- Quad-port flexi ATU-C line card (4xflexi)
- Quad-port STU-C line card (4xSDSL)
- Octal-port DMT ATU-C line card (8xDMT)
- Octal-Port DMT ATU-C over ISDN line card (8xDMT over ISDN)
- Octal-Port G.SHDSL SHTU-C line card (8xG.SHDSL)
- DS3/2DS3 NI-2 card
- DS3+T1/E1 IMA NI-2 card
- OC-3c/OC-3c NI-2 card
- I/O module (E3, E1, or OC-3c)
- Power entry module (PEM)
- Fan Tray

## A.1.1 Cisco 6260 Chassis

Table A-1 lists the hardware specifications of the Cisco 6260 system.

**Table A-1 Cisco 6260 Hardware Specifications**

| Specification                                       |                    | Description                                                                                                                                                                |
|-----------------------------------------------------|--------------------|----------------------------------------------------------------------------------------------------------------------------------------------------------------------------|
| Dimensions                                          |                    | 13.43 RUs—23.5 in. x 17.5 in. x 11.0 in. (59.7 cm x 44.5 cm x 28.0 cm)                                                                                                     |
| Weight                                              |                    | Empty—Approximately 37.5 lb (17.0 kg)<br>Loaded—Approximately 80 lb (36.3 kg)                                                                                              |
| Network interface                                   |                    | ATM OC-3c (single- or multimode fiber), ATM E3, ATM E1<br><br><b>Note</b> When the DS3/2DS3 NI-2 card is installed in the Cisco 6260 chassis, it assumes E3 functionality. |
| ADSL interface                                      |                    | DMT—Up to 8.032 Mbps downstream/864 kbps upstream<br>G.lite—Up to 1.536 Mbps downstream/512 kbps upstream                                                                  |
| SDSL interface                                      |                    | 2B1Q—Up to 1168 kbps upstream and downstream                                                                                                                               |
| SHDSL interface                                     |                    | TC-PAM <sup>1</sup>                                                                                                                                                        |
| Craft interface                                     |                    | Console terminal connection on the NI-2 card                                                                                                                               |
| Management access                                   |                    | <ul style="list-style-type: none"> <li>• RJ-45 interface for craft alarm discovery</li> <li>• RJ-45 Ethernet</li> <li>• ATM in-band management</li> </ul>                  |
| External alarm contacts                             |                    | Single dry contact alarm input (NO)                                                                                                                                        |
| Power requirements                                  |                    | <ul style="list-style-type: none"> <li>• -40.5 VDC to -75 VDC</li> </ul> <b>Note</b> See Chapter 2, “Preparing for Installation,” for detailed power requirements.         |
| CO operating requirements                           | Temperature        | 41° to 104°F (5° to 40°C)—Operating<br>23° to 131°F (-5° to 55°C)—Short-term operating                                                                                     |
|                                                     | Altitude           | 0 to 10,000 feet (0 to 3048 meters)—Operating<br>0 to 30,000 feet (0 to 9144 meters)—Nonoperating                                                                          |
|                                                     | Humidity           | 5 to 95% (noncondensing)                                                                                                                                                   |
|                                                     | Operating shock    | 5 to 500 Hz, 0.5 gravity (0.1 octave per minute)                                                                                                                           |
|                                                     | Nonoperating shock | 5 to 100 Hz, 1 gravity (0.1 octave per minute);<br>100 to 500 Hz, 1.5 gravities (0.2 octave per minute);<br>500 to 1000 Hz, 1.5 gravities (0.2 octave per minute)          |
| Maximum heat dissipation for a fully loaded chassis |                    | 4097 BTUs/hour                                                                                                                                                             |

**Table A-1 Cisco 6260 Hardware Specifications (continued)**

| Specification  | Description                                                                                                                                                                                                                                                                                                                  |
|----------------|------------------------------------------------------------------------------------------------------------------------------------------------------------------------------------------------------------------------------------------------------------------------------------------------------------------------------|
| Acoustic noise | 60 dB at normal fan speed                                                                                                                                                                                                                                                                                                    |
| Subtending     | <ul style="list-style-type: none"> <li>One OC-3c connection on the OC-3c/OC-3c NI-2 card</li> <li>Two E3 connections on the E3 I/O module when used in conjunction with the DS3/2DS3 NI-2 card</li> <li>Up to seven E1 connections on the E1 I/O module when used in conjunction with the DS3+T1/E1 IMA NI-2 card</li> </ul> |

1. TC-PAM = trellis coded pulse amplitude modulation

## A.1.2 Quad-Port DMT ATU-C Line Card

Table A-2 lists the specifications for the 4xDMT.

**Table A-2 Quad-Port DMT ATU-C Line Card Specifications**

| Specification                                       | Description                                                                                                                                                                                    |
|-----------------------------------------------------|------------------------------------------------------------------------------------------------------------------------------------------------------------------------------------------------|
| Standards supported                                 | ITU G.dmt<br>ITU G.lite<br>ANSI T1.413 Issue 2                                                                                                                                                 |
| External interfaces                                 | 4 (no connectors on card)                                                                                                                                                                      |
| Data rates (per port)                               | Upstream: Up to 864 kbps<br>Downstream: Up to 8.032 Mbps                                                                                                                                       |
| Internal hardware                                   | <ul style="list-style-type: none"> <li>18 MHz AM186ESLV.2 CPU</li> <li>AD20msp918 DMT modem chipset</li> <li>128 KB SRAM</li> <li>256 K x 16 boot flash</li> <li>2 KB serial EEPROM</li> </ul> |
| Dimensions                                          | Height: 6.07 in. (15.42 cm)<br>Depth: 8.50 in. (21.59 cm)<br>Width: 0.88 in. (2.24 cm)                                                                                                         |
| Weight                                              | 0.875 lb (0.4 kg)                                                                                                                                                                              |
| Power consumption                                   | 16.5W                                                                                                                                                                                          |
| Minimum software and network management requirement | Cisco IOS—Release 12.0(5)DA<br>CDM <sup>1</sup> —Release 3.0 (optional)                                                                                                                        |

1. CDM = Cisco DSL Manager

## A.1.3 Quad-Port DMT over ISDN Line Card

Table A-3 lists the specifications for the 4xDMT over ISDN.

**Table A-3 Quad-Port DMT Over ISDN Line Card Specifications**

| Specification                                       | Description                                                                                                                                                                                              |
|-----------------------------------------------------|----------------------------------------------------------------------------------------------------------------------------------------------------------------------------------------------------------|
| Data rates (per port)                               | Upstream: 32 to 864 kbps in increments of 32 kbps<br>Downstream: 32 to 8032 kbps in increments of 32 kbps<br>Symmetrical: Matches upstream and downstream rates                                          |
| Internal hardware                                   | <ul style="list-style-type: none"> <li>• 18 MHz AM186ESLV.2 CPU</li> <li>• AD20msp918 DMT modem chipset</li> <li>• 128 KB SRAM</li> <li>• 256 K x 16 boot flash</li> <li>• 2 KB serial EEPROM</li> </ul> |
| Dimensions                                          | Height: 6.07 in. (15.42 cm)<br>Depth: 8.50 in. (21.59 cm)<br>Width: 0.88 in. (2.24 cm)                                                                                                                   |
| Weight                                              | 0.875 lb (0.4 kg)                                                                                                                                                                                        |
| Power consumption                                   | 16.5W                                                                                                                                                                                                    |
| Minimum software and network management requirement | Cisco IOS—Release 12.1(3)DA<br>CDM—Release 3.2 (optional)                                                                                                                                                |

## A.1.4 Quad-Port Flexi ATU-C Line Card

Table A-4 lists the specifications for the 4xflexi.

**Table A-4 Quad-Port Flexi ATU-C Line Card Specifications**

| Specification         | Description                                  |
|-----------------------|----------------------------------------------|
| Standards supported   | ITU G.dmt (G.992.1)<br>ANSI T1.413           |
| Power consumption     | 17.5W                                        |
| Data rates (per port) | Downstream: 8.032 Mbps<br>Upstream: 864 kbps |



**Table A-4 Quad-Port Flexi ATU-C Line Card Specifications (continued)**

| Specification                                       | Description                                                                            |
|-----------------------------------------------------|----------------------------------------------------------------------------------------|
| External interfaces                                 | 4 (no connectors on card)                                                              |
| Internal hardware                                   | AMD 186-based 3.3V 18-MHz CPU<br>128 KB SRAM<br>512 K flash                            |
| Dimensions                                          | Height: 6.07 in. (15.42 cm)<br>Depth: 8.50 in. (21.59 cm)<br>Width: 0.88 in. (2.24 cm) |
| Weight                                              | 0.875 lb (0.4 kg)                                                                      |
| Minimum software and network management requirement | Cisco IOS—Release 12.1(4)DA<br>CDM—Release 3.2 (optional)                              |

## A.1.5 Quad-Port STU-C Line Card

Table A-5 lists the specifications for the 4xSDSL.

**Table A-5 Quad-Port STU-C Line Card Specifications**

| Specification                                       | Description                                                                            |
|-----------------------------------------------------|----------------------------------------------------------------------------------------|
| Standards supported                                 | ITU G.991.1                                                                            |
| External interfaces                                 | 4 (no connectors on card)                                                              |
| Data rates (per port)                               | Downstream: 1168 kbps<br>Upstream: 1168 kbps                                           |
| Line encoding                                       | 2B1Q                                                                                   |
| Internal hardware                                   | AMD 186-based 3.3V 18-MHz CPU<br>128 KB SRAM<br>512 K flash                            |
| Dimensions                                          | Height: 6.07 in. (15.42 cm)<br>Depth: 8.50 in. (21.59 cm)<br>Width: 0.88 in. (2.24 cm) |
| Weight                                              | 0.875 lb (0.4 kg)                                                                      |
| Power consumption                                   | 9W                                                                                     |
| Minimum software and network management requirement | Cisco IOS—Release 12.1(4)DA<br>CDM—Release 3.0 (optional)                              |

## A.1.6 Octal-Port DMT ATU-C Line Card

Table A-6 lists the specifications for the 8xDMT.

**Table A-6** *Octal-Port DMT ATU-C Line Card Specifications*

| Specification                                       | Description                                                                                                                                                                                                                                                                                                                                                                                                                                      |
|-----------------------------------------------------|--------------------------------------------------------------------------------------------------------------------------------------------------------------------------------------------------------------------------------------------------------------------------------------------------------------------------------------------------------------------------------------------------------------------------------------------------|
| Standards supported                                 | <ul style="list-style-type: none"> <li>• ANSI T1.413-Issue 2, Category 1 only</li> <li>• ANSI T1.413-Issue 2, Annex F (Reduced NEXT)</li> <li>• Universal Test &amp; Operations PHY for ATM, Level 2; A standard for transport of ATM cells over a 16-bit parallel data bus. Refer to the ATM Forum document af-phy-0039.000.</li> <li>• ITU G.992.1, Annex A (G.dmt)</li> <li>• ITU G.992.2. (G.lite)</li> <li>• ITU G.994.1. (G.hs)</li> </ul> |
| External interfaces                                 | 8 (no connectors on card)                                                                                                                                                                                                                                                                                                                                                                                                                        |
| Data rates (per port)                               | Upstream: Up to 1024 kbps<br>Downstream: Up to 8.064 Mbps                                                                                                                                                                                                                                                                                                                                                                                        |
| Internal hardware                                   | <ul style="list-style-type: none"> <li>• 40 MHz Motorola MPC850 microprocessor</li> <li>• 8 MB SDRAM</li> <li>• 1 Mb boot flash</li> <li>• 1 KB serial EEPROM</li> </ul>                                                                                                                                                                                                                                                                         |
| Dimensions                                          | Height: 6.07 in. (15.42 cm)<br>Depth: 8.50 in. (21.59 cm)<br>Width: 0.88 in. (2.24 cm)                                                                                                                                                                                                                                                                                                                                                           |
| Weight                                              | 0.875 lb (0.4 kg)                                                                                                                                                                                                                                                                                                                                                                                                                                |
| Power consumption                                   | 24W                                                                                                                                                                                                                                                                                                                                                                                                                                              |
| Minimum software and network management requirement | Cisco IOS—Release 12.1(6)DA<br>CDM—Release 3.3(2)                                                                                                                                                                                                                                                                                                                                                                                                |

## A.1.7 Octal-Port DMT ATU-C Over ISDN Line Card

Table A-7 lists the specifications for the 8xDMT over ISDN.

**Table A-7 Octal-Port DMT ATU-C Over ISDN Line Card Specifications**

| Specification                                       | Description                                                                                                                                                                                                                                                                                                                                                                                                                   |
|-----------------------------------------------------|-------------------------------------------------------------------------------------------------------------------------------------------------------------------------------------------------------------------------------------------------------------------------------------------------------------------------------------------------------------------------------------------------------------------------------|
| Standards supported                                 | <ul style="list-style-type: none"> <li>• Universal Test &amp; Operations PHY for ATM, Level 2; a standard for transport of ATM cells over a 16-bit parallel data bus. Refer to the ATM Forum document af-phy-0039.000.</li> <li>• ITU G.992.1 (G.dmt), Annex B/ETSI</li> <li>• ITU G.994.1 (G.hs)</li> <li>• ETSI TS 101 388 V.1.1.1/(draft) TM6(98)12</li> <li>• TS102 080 v1.3.2 -Support for 2B1Q and 4B3T ISDN</li> </ul> |
| External interfaces                                 | 8 (no connectors on card)                                                                                                                                                                                                                                                                                                                                                                                                     |
| Data rates (per port)                               | Upstream: Up to 1024 kbps<br>Downstream: Up to 7.616 Mbps                                                                                                                                                                                                                                                                                                                                                                     |
| Framing modes                                       | Overhead Framing Mode 3 supported                                                                                                                                                                                                                                                                                                                                                                                             |
| Internal hardware                                   | <ul style="list-style-type: none"> <li>• 40 MHz Motorola MPC850 microprocessor</li> <li>• 8 MB SDRAM</li> <li>• 8 Mb boot flash</li> <li>• 1 KB serial EEPROM</li> </ul>                                                                                                                                                                                                                                                      |
| Dimensions                                          | Height: 6.07 in. (15.42 cm)<br>Depth: 8.62 in. (21.89 cm)<br>Width: 0.88 in. (2.24 cm)                                                                                                                                                                                                                                                                                                                                        |
| Weight                                              | 0.875 lb (0.4 kg)                                                                                                                                                                                                                                                                                                                                                                                                             |
| Power consumption                                   | 24W                                                                                                                                                                                                                                                                                                                                                                                                                           |
| Minimum software and network management requirement | Cisco IOS—Release 12.2(5) DA                                                                                                                                                                                                                                                                                                                                                                                                  |

## A.1.8 Octal-Port G.SHDSL SHTU-C Line Card

Table A-8 lists the specifications for the 8xG.SHDSL.

**Table A-8 Octal-port G.SHDSL SHTU-C Line Card Specifications**

| Specification       | Description                                                     |
|---------------------|-----------------------------------------------------------------|
| Standards supported | TC-PAM without OPTIS<br>ETSI SDSL, TM6(00)10                    |
| Power consumption   | 11.3W at 136 kbps<br>15.0W at 1.554 Mbps<br>16.5W at 2.312 Mbps |

**Table A-8** Octal-port G.SHDSL SHTU-C Line Card Specifications (continued)

| Specification                                       | Description                                                                                 |
|-----------------------------------------------------|---------------------------------------------------------------------------------------------|
| Maximum data rates (per port)                       | 2.312 Mbps                                                                                  |
| Maximum data rate (per card)                        | 18.5 Mbps downstream<br>5.0 Mbps for odd ports upstream<br>5.0 Mbps for even ports upstream |
| External interfaces                                 | 8 (no connectors on card)                                                                   |
| Internal hardware                                   | MPC850 3.3V power 40-MHz CPU                                                                |
| Dimensions                                          | Height: 6.07 in. (15.42 cm)<br>Depth: 8.50 in. (21.59 cm)<br>Width: 0.88 in. (2.24 cm)      |
| Weight                                              | 0.70 lb (0.32 kg)                                                                           |
| Minimum software and network management requirement | Cisco IOS 12.1.(7) DA<br>CDM 3.3(3) (optional)                                              |

## A.1.9 DS3/2DS3 NI-2 Card

Table A-9 lists the specifications for the DS3/2DS3 NI-2 card.

**Table A-9** DS3/2DS3 NI-2 Card Specifications

| Specification       | Description                                                                                                            |
|---------------------|------------------------------------------------------------------------------------------------------------------------|
| Internal hardware   | 150 MHz RC64475 CPU<br>Galileo GT64120 system controller<br>1 M x 32 bootflash<br>4 M x 32 flash<br>512 KB boot EEPROM |
| Dimensions          | Height: 12.38 in. (31.45 cm)<br>Depth: 8.50 in. (21.59 cm)<br>Width: 1.80 in. (4.57 cm)                                |
| Weight              | 3.0 lb (1.36 kg)                                                                                                       |
| Layer 2 protocol    | ATM                                                                                                                    |
| External interfaces | Three DS3/E3 (44.736 Mbps) coaxial ports                                                                               |
| Connector type      | BNC <sup>1</sup>                                                                                                       |
| Impedance           | 75 ohms (nominal)                                                                                                      |
| Line encoding       | B3ZS                                                                                                                   |
| Framing             | C-bit parity, optionally PLCP with M23, otherwise add/drop multiplexer (ADM)                                           |

**Table A-9 DS3/2DS3 NI-2 Card Specifications (continued)**

| Specification                                       | Description                                                               |
|-----------------------------------------------------|---------------------------------------------------------------------------|
| Power consumption                                   | 33.5W                                                                     |
| Minimum software and network management requirement | Cisco IOS—Release 12.1(5)DA <sup>2</sup><br>CDM—Release 3.3(1) (optional) |

1. The Bayonet-Neill-Concelman (BNC) connectors are located on the E3 I/O module.
2. The minimum Cisco IOS software requirement for a redundant NI-2 card configuration is 12.1(7)DA.

## A.1.10 DS3+T1/E1 IMA NI-2 Card

Table A-10 lists the specifications for the DS3+T1/E1 IMA NI-2 card.

**Table A-10 DS3+T1/E1 IMA NI-2 Card Specifications**

| Specification                    | Description                                                                                                                    |
|----------------------------------|--------------------------------------------------------------------------------------------------------------------------------|
| Internal hardware                | 150 MHz RC64475 CPU<br>Galileo GT64120 system controller<br>1Mx32 bootflash (4 MB)<br>4Mx32 flash (16 MB)<br>512 KB boot EPROM |
| Dimensions                       | Height: 12.38 in. (31.45 cm)<br>Depth: 8.50 in. (21.59 cm)<br>Width: 1.80 in. (4.57 cm)                                        |
| Weight                           | 3.0 lb (1.36 kg)                                                                                                               |
| External interfaces <sup>1</sup> | Eight T1(1.544 Mbps)/E1 (2.048 Mbps) RJ-48 ports                                                                               |
| Connector types <sup>2</sup>     | E1/T1—RJ-48                                                                                                                    |
| Impedance                        | E1—120 ohms (nominal)                                                                                                          |
| Line encoding                    | E1—AMI or HDB3                                                                                                                 |
| Framing                          | E1—PCM30 or CRC4                                                                                                               |

**Table A-10 DS3+T1/E1 IMA NI-2 Card Specifications (continued)**

| Specification                                       | Description                                                                                                  |
|-----------------------------------------------------|--------------------------------------------------------------------------------------------------------------|
| Transmission distance                               | E1—Short haul: 0 to 655 feet (0 to 199.64 meters),<br>long haul: > 655 feet (199.64 meters)<br>no span power |
| Power consumption                                   | 32.5W                                                                                                        |
| Minimum software and network management requirement | Cisco IOS—Release 12.1(7)DA<br>CDM—Release 3.3(3) (optional)                                                 |

1. All external interfaces for the DS3+T1/E1 IMA NI-2 card are located on the I/O module.
2. All trunk and subtend connectors for the DS3+T1/E1 IMA NI-2 card are located on the I/O module.

## A.1.11 OC-3c/OC-3c NI-2 Card

Table A-11 lists the specifications of the single-mode and multimode versions of the OC-3c/OC-3c NI-2 card.

**Table A-11 OC-3c/OC-3c NI-2 Card Specifications**

| Specification                                       | Description                                                                                                                               |                                            |
|-----------------------------------------------------|-------------------------------------------------------------------------------------------------------------------------------------------|--------------------------------------------|
| Internal hardware                                   | 150 MHz RC64475 CPU<br>Galileo GT64120 system controller<br>1 M x 32 bootflash <sup>1</sup> (4 MB)<br>4 M x 32 Flash<br>512 KB boot EPROM |                                            |
| Dimensions                                          | Height: 12.38 in. (31.45 cm)<br>Depth: 8.50 in. (21.59 cm)<br>Width: 1.80 in. (4.57 cm)                                                   |                                            |
| Weight                                              | 3.0 lb (1.36 kg)                                                                                                                          |                                            |
| Layer 2 protocol                                    | ATM                                                                                                                                       |                                            |
| Power consumption                                   | 33.5W                                                                                                                                     |                                            |
| Minimum software and network management requirement | Cisco IOS—Release 12.0(5)DA <sup>2</sup><br>CDM—Release 3.0 (optional)                                                                    |                                            |
|                                                     | Single Mode Card                                                                                                                          | Multimode Card                             |
| External interfaces                                 | Two OC-3c/STM-1 (155 Mbps) single-mode ports                                                                                              | Two OC-3c/STM-1 (155 Mbps) multimode ports |
| Connector type                                      | SC-PC                                                                                                                                     | SC-PC                                      |
| Fiber type                                          | Intermediate reach single mode                                                                                                            | Multimode                                  |
| Average transmitted power                           | -15 to -8 dBm                                                                                                                             | -20 to -14 dBm                             |
| Average received power                              | -8 dBm                                                                                                                                    | -11 dBm                                    |
| Transmission distance                               | Up to 20 km (12 miles)                                                                                                                    | Up to 2 km (1.2 miles)                     |
| Wavelength                                          | 1310 nm                                                                                                                                   | 1300 nm                                    |

1. The version of the OC-3c/OC-3c NI-2 card with enhanced upstream bandwidth features (NI2-155SM-155SM2 and NI2-155MM-155MM2) has a 2M x 32 bootflash (8 MB).
2. The minimum Cisco IOS software requirement for a redundant NI-2 card configuration is 12.1(7)DA.

## A.1.12 I/O Module

Table A-12 lists the specifications for the E3, E1, and OC-3c I/O modules.

**Table A-12 I/O Module Specifications**

| Specification                                       | E3                                                                                     | E1                                                                                 | OC-3c                                                                                  |
|-----------------------------------------------------|----------------------------------------------------------------------------------------|------------------------------------------------------------------------------------|----------------------------------------------------------------------------------------|
| Dimensions                                          | Height: 2.34 in. (5.94 cm)<br>Depth: 1.19 in. (3.022 cm)<br>Width: 17.0 in. (43.18 cm) | Height: 2.34 in. (5.94 cm)<br>Depth: 1.18 in. (3 cm)<br>Width: 17.0 in. (43.18 cm) | Height: 2.34 in. (5.94 cm)<br>Depth: 0.785 in. (1.99 cm)<br>Width: 17.0 in. (43.18 cm) |
| Weight                                              | 1.75 lb (0.79 kg)                                                                      | 1.65 lb (0.75 kg)                                                                  | 1.2 lb (0.54 kg)                                                                       |
| External interfaces                                 | Three E3 (32.064 Mbps) coaxial ports                                                   | Eight E1 (2.048 Mbps) receptacle connectors                                        | Not applicable                                                                         |
| Connector type                                      | E3—BNC                                                                                 | E1—RJ-48                                                                           | Not applicable                                                                         |
| Power consumption                                   | Not applicable                                                                         | Not applicable                                                                     | Not applicable                                                                         |
| Minimum software and network management requirement | Cisco IOS—Release 12.1(4)DA<br>CDM—Release 3.3 (optional)                              | Cisco IOS—Release 12.1(7)DA2<br>CDM—Release 3.3(2) (optional)                      | Cisco IOS—Release 12.0(5)DA<br>CDM—Release 3.0 (optional)                              |

## A.1.13 PEM

Table A-13 lists the specifications for the PEM.

**Table A-13 PEM Specifications**

| Specification                                       | PEM                                                                                     |
|-----------------------------------------------------|-----------------------------------------------------------------------------------------|
| Dimensions                                          | Height: 2.45 in. (6.22 cm)<br>Depth: 10.86 in. (27.58 cm)<br>Width: 7.96 in. (20.22 cm) |
| Weight                                              | 5.85 lb (2.65 kg)                                                                       |
| Power consumption                                   | 50.159W                                                                                 |
| Minimum software and network management requirement | Cisco IOS—Release 12.0(5)DA<br>CDM—Release 3.0 (optional)                               |

## A.1.14 Fan Tray

Table A-14 lists the specifications for the fan tray.

**Table A-14 Fan Tray Specifications**

| Specification                                       | Description                                                                          |
|-----------------------------------------------------|--------------------------------------------------------------------------------------|
| Dimensions                                          | Height: 1.5 in. (3.81 cm)<br>Depth: 8.75 in. (22.23 cm)<br>Width: 8.5 in. (21.59 cm) |
| Weight                                              | 2.6 lb (1.18 kg)                                                                     |
| Power consumption                                   | 34.5W                                                                                |
| Minimum software and network management requirement | Cisco IOS—Release 12.1(4)DA<br>CDM—Release 3.2 (optional)                            |

## A.2 Software Specifications

Table A-15 lists Cisco 6260 system software specifications.

**Table A-15 Software Specifications**

| Specification           | Description                                                                  |
|-------------------------|------------------------------------------------------------------------------|
| Management protocols    | IOS software support for SNMP to Cisco EMF <sup>1</sup>                      |
| Management applications | <ul style="list-style-type: none"> <li>• Cisco IOS</li> <li>• CDM</li> </ul> |
| Management interfaces   | In band—ATM VC<br>Out of band—10BaseT Ethernet, console, auxiliary           |

1. EMF = Element Management Framework





## Port Mapping Specifications

---

This appendix provides a subscriber connector port mapping table.

Cisco used a standard telco color chart when designing the cables for the Cisco 6260 connections. This appendix includes a standard telco color chart.

### B.1 Port Mapping Table

The Cisco 6260 subscriber connectors are numbered 1 to 10. Table B-1 shows how subscriber connectors correspond to card slots and ports. In the table, an asterisk (\*) indicates a port that is not available on quad-port xTU-C line cards.

Table B-1 Port Mapping for Cisco 6260 Subscriber Connectors

| Slot/Line | Champ Pin |      | Cisco 6260 Connector   | Slot/Line | Champ Pin |      | Cisco 6260 Connector     |
|-----------|-----------|------|------------------------|-----------|-----------|------|--------------------------|
|           | Tip       | Ring |                        |           | Tip       | Ring |                          |
| 1/1       | 26        | 1    | 1<br>Slots 1 through 3 | 18/1      | 26        | 1    | 2<br>Slots 18 through 20 |
| 1/2       | 27        | 2    |                        | 18/2      | 27        | 2    |                          |
| 1/3       | 28        | 3    |                        | 18/3      | 28        | 3    |                          |
| 1/4       | 29        | 4    |                        | 18/4      | 29        | 4    |                          |
| 1/5*      | 30        | 5    |                        | 18/5*     | 30        | 5    |                          |
| 1/6*      | 31        | 6    |                        | 18/6*     | 31        | 6    |                          |
| 1/7*      | 32        | 7    |                        | 18/7*     | 32        | 7    |                          |
| 1/8*      | 33        | 8    |                        | 18/8*     | 33        | 8    |                          |
| 2/1       | 34        | 9    |                        | 19/1      | 34        | 9    |                          |
| 2/2       | 35        | 10   |                        | 19/2      | 35        | 10   |                          |
| 2/3       | 36        | 11   |                        | 19/3      | 36        | 11   |                          |
| 2/4       | 37        | 12   |                        | 19/4      | 37        | 12   |                          |
| 2/5*      | 38        | 13   |                        | 19/5*     | 38        | 13   |                          |
| 2/6*      | 39        | 14   |                        | 19/6*     | 39        | 14   |                          |
| 2/7*      | 40        | 15   |                        | 19/7*     | 40        | 15   |                          |
| 2/8*      | 41        | 16   |                        | 19/8*     | 41        | 16   |                          |
| 3/1       | 42        | 17   |                        | 20/1      | 42        | 17   |                          |
| 3/2       | 43        | 18   |                        | 20/2      | 43        | 18   |                          |
| 3/3       | 44        | 19   |                        | 20/3      | 44        | 19   |                          |
| 3/4       | 45        | 20   |                        | 20/4      | 45        | 20   |                          |
| 3/5*      | 46        | 21   |                        | 20/5*     | 46        | 21   |                          |
| 3/6*      | 47        | 22   |                        | 20/6*     | 47        | 22   |                          |
| 3/7*      | 48        | 23   |                        | 20/7*     | 48        | 23   |                          |
| 3/8*      | 49        | 24   |                        | 20/8*     | 49        | 24   |                          |

Table B-1 Port Mapping for Cisco 6260 Subscriber Connectors (continued)

| Slot/Line | Champ Pin |      | Cisco 6260 Connector   | Slot/Line | Champ Pin |      | Cisco 6260 Connector     |
|-----------|-----------|------|------------------------|-----------|-----------|------|--------------------------|
|           | Tip       | Ring |                        |           | Tip       | Ring |                          |
| 4/1       | 26        | 1    | 3<br>Slots 4 through 6 | 21/1      | 26        | 1    | 4<br>Slots 21 through 23 |
| 4/2       | 27        | 2    |                        | 21/2      | 27        | 2    |                          |
| 4/3       | 28        | 3    |                        | 21/3      | 28        | 3    |                          |
| 4/4       | 29        | 4    |                        | 21/4      | 29        | 4    |                          |
| 4/5*      | 30        | 5    |                        | 21/5*     | 30        | 5    |                          |
| 4/6*      | 31        | 6    |                        | 21/6*     | 31        | 6    |                          |
| 4/7*      | 32        | 7    |                        | 21/7*     | 32        | 7    |                          |
| 4/8*      | 33        | 8    |                        | 21/8*     | 33        | 8    |                          |
| 5/1       | 34        | 9    |                        | 22/1      | 34        | 9    |                          |
| 5/2       | 35        | 10   |                        | 22/2      | 35        | 10   |                          |
| 5/3       | 36        | 11   |                        | 22/3      | 36        | 11   |                          |
| 5/4       | 37        | 12   |                        | 22/4      | 37        | 12   |                          |
| 5/5*      | 38        | 13   |                        | 22/5*     | 38        | 13   |                          |
| 5/6*      | 39        | 14   |                        | 22/6*     | 39        | 14   |                          |
| 5/7*      | 40        | 15   |                        | 22/7*     | 40        | 15   |                          |
| 5/8*      | 41        | 16   |                        | 22/8*     | 41        | 16   |                          |
| 6/1       | 42        | 17   |                        | 23/1      | 42        | 17   |                          |
| 6/2       | 43        | 18   |                        | 23/2      | 43        | 18   |                          |
| 6/3       | 44        | 19   |                        | 23/3      | 44        | 19   |                          |
| 6/4       | 45        | 20   |                        | 23/4      | 45        | 20   |                          |
| 6/5*      | 46        | 21   |                        | 23/5*     | 46        | 21   |                          |
| 6/6*      | 47        | 22   |                        | 23/6*     | 47        | 22   |                          |
| 6/7*      | 48        | 23   |                        | 23/7*     | 48        | 23   |                          |
| 6/8*      | 49        | 24   |                        | 23/8*     | 49        | 24   |                          |

Table B-1 Port Mapping for Cisco 6260 Subscriber Connectors (continued)

| Slot/Line | Champ Pin |      | Cisco 6260 Connector   | Slot/Line | Champ Pin |      | Cisco 6260 Connector     |
|-----------|-----------|------|------------------------|-----------|-----------|------|--------------------------|
|           | Tip       | Ring |                        |           | Tip       | Ring |                          |
| 7/1       | 26        | 1    | 5<br>Slots 7 through 9 | 24/1      | 26        | 1    | 6<br>Slots 24 through 26 |
| 7/2       | 27        | 2    |                        | 24/2      | 27        | 2    |                          |
| 7/3       | 28        | 3    |                        | 24/3      | 28        | 3    |                          |
| 7/4       | 29        | 4    |                        | 24/4      | 29        | 4    |                          |
| 7/5*      | 30        | 5    |                        | 24/5*     | 30        | 5    |                          |
| 7/6*      | 31        | 6    |                        | 24/6*     | 31        | 6    |                          |
| 7/7*      | 32        | 7    |                        | 24/7*     | 32        | 7    |                          |
| 7/8*      | 33        | 8    |                        | 24/8*     | 33        | 8    |                          |
| 8/1       | 34        | 9    |                        | 25/1      | 34        | 9    |                          |
| 8/2       | 35        | 10   |                        | 25/2      | 35        | 10   |                          |
| 8/3       | 36        | 11   |                        | 25/3      | 36        | 11   |                          |
| 8/4       | 37        | 12   |                        | 25/4      | 37        | 12   |                          |
| 8/5*      | 38        | 13   |                        | 25/5*     | 38        | 13   |                          |
| 8/6*      | 39        | 14   |                        | 25/6*     | 39        | 14   |                          |
| 8/7*      | 40        | 15   |                        | 25/7*     | 40        | 15   |                          |
| 8/8*      | 41        | 16   |                        | 25/8*     | 41        | 16   |                          |
| 9/1       | 42        | 17   | 26/1                   | 42        | 17        |      |                          |
| 9/2       | 43        | 18   | 26/2                   | 43        | 18        |      |                          |
| 9/3       | 44        | 19   | 26/3                   | 44        | 19        |      |                          |
| 9/4       | 45        | 20   | 26/4                   | 45        | 20        |      |                          |
| 9/5*      | 46        | 21   | 26/5*                  | 46        | 21        |      |                          |
| 9/6*      | 47        | 22   | 26/6*                  | 47        | 22        |      |                          |
| 9/7*      | 48        | 23   | 26/7*                  | 48        | 23        |      |                          |
| 9/8*      | 49        | 24   | 26/8*                  | 49        | 24        |      |                          |

Table B-1 Port Mapping for Cisco 6260 Subscriber Connectors (continued)

| Slot/Line | Champ Pin |      | Cisco 6260 Connector     | Slot/Line | Champ Pin |      | Cisco 6260 Connector     |
|-----------|-----------|------|--------------------------|-----------|-----------|------|--------------------------|
|           | Tip       | Ring |                          |           | Tip       | Ring |                          |
| 27/1      | 26        | 1    | 7<br>Slots 27 through 29 | 12/1      | 26        | 1    | 8<br>Slots 12 through 14 |
| 27/2      | 27        | 2    |                          | 12/2      | 27        | 2    |                          |
| 27/3      | 28        | 3    |                          | 12/3      | 28        | 3    |                          |
| 27/4      | 29        | 4    |                          | 12/4      | 29        | 4    |                          |
| 27/5*     | 30        | 5    |                          | 12/5*     | 30        | 5    |                          |
| 27/6*     | 31        | 6    |                          | 12/6*     | 31        | 6    |                          |
| 27/7*     | 32        | 7    |                          | 12/7*     | 32        | 7    |                          |
| 27/8*     | 33        | 8    |                          | 12/8*     | 33        | 8    |                          |
| 28/1      | 34        | 9    |                          | 13/1      | 34        | 9    |                          |
| 28/2      | 35        | 10   |                          | 13/2      | 35        | 10   |                          |
| 28/3      | 36        | 11   |                          | 13/3      | 36        | 11   |                          |
| 28/4      | 37        | 12   |                          | 13/4      | 37        | 12   |                          |
| 28/5*     | 38        | 13   |                          | 13/5*     | 38        | 13   |                          |
| 28/6*     | 39        | 14   |                          | 13/6*     | 39        | 14   |                          |
| 28/7*     | 40        | 15   |                          | 13/7*     | 40        | 15   |                          |
| 28/8*     | 41        | 16   |                          | 13/8*     | 41        | 16   |                          |
| 29/1      | 42        | 17   |                          | 14/1      | 42        | 17   |                          |
| 29/2      | 43        | 18   |                          | 14/2      | 43        | 18   |                          |
| 29/3      | 44        | 19   |                          | 14/3      | 44        | 19   |                          |
| 29/4      | 45        | 20   |                          | 14/4      | 45        | 20   |                          |
| 29/5*     | 46        | 21   |                          | 14/5*     | 46        | 21   |                          |
| 29/6*     | 47        | 22   |                          | 14/6*     | 47        | 22   |                          |
| 29/7*     | 48        | 23   |                          | 14/7*     | 48        | 23   |                          |
| 29/8*     | 49        | 24   |                          | 14/8*     | 49        | 24   |                          |

Table B-1 Port Mapping for Cisco 6260 Subscriber Connectors (continued)

| Slot/Line | Champ Pin |      | Cisco 6260 Connector     | Slot/Line | Champ Pin |      | Cisco 6260 Connector      |
|-----------|-----------|------|--------------------------|-----------|-----------|------|---------------------------|
|           | Tip       | Ring |                          |           | Tip       | Ring |                           |
| 30/1      | 26        | 1    | 9<br>Slots 30 through 32 | 15/1      | 26        | 1    | 10<br>Slots 15 through 17 |
| 30/2      | 27        | 2    |                          | 15/2      | 27        | 2    |                           |
| 30/3      | 28        | 3    |                          | 15/3      | 28        | 3    |                           |
| 30/4      | 29        | 4    |                          | 15/4      | 29        | 4    |                           |
| 30/5*     | 30        | 5    |                          | 15/5*     | 30        | 5    |                           |
| 30/6*     | 31        | 6    |                          | 15/6*     | 31        | 6    |                           |
| 30/7*     | 32        | 7    |                          | 15/7*     | 32        | 7    |                           |
| 30/8*     | 33        | 8    |                          | 15/8*     | 33        | 8    |                           |
| 31/1      | 34        | 9    |                          | 16/1      | 34        | 9    |                           |
| 31/2      | 35        | 10   |                          | 16/2      | 35        | 10   |                           |
| 31/3      | 36        | 11   |                          | 16/3      | 36        | 11   |                           |
| 31/4      | 37        | 12   |                          | 16/4      | 37        | 12   |                           |
| 31/5*     | 38        | 13   |                          | 16/5*     | 38        | 13   |                           |
| 31/6*     | 39        | 14   |                          | 16/6*     | 39        | 14   |                           |
| 31/7*     | 40        | 15   |                          | 16/7*     | 40        | 15   |                           |
| 31/8*     | 41        | 16   |                          | 16/8*     | 41        | 16   |                           |
| 32/1      | 42        | 17   |                          | 17/1      | 42        | 17   |                           |
| 32/2      | 43        | 18   |                          | 17/2      | 43        | 18   |                           |
| 32/3      | 44        | 19   |                          | 17/3      | 44        | 19   |                           |
| 32/4      | 45        | 20   |                          | 17/4      | 45        | 20   |                           |
| 32/5*     | 46        | 21   |                          | 17/5*     | 46        | 21   |                           |
| 32/6*     | 47        | 22   |                          | 17/6*     | 47        | 22   |                           |
| 32/7*     | 48        | 23   |                          | 17/7*     | 48        | 23   |                           |
| 32/8*     | 49        | 24   |                          | 17/8*     | 49        | 24   |                           |

## B.2 Standard Telco Color Chart

In designing the cables for the Cisco 6260 connections, Cisco used a standard telco color chart. Table B-2 lists the colors that are used for the Cisco 6260 cables.

Table B-2 Standard Telco Color Chart

| Wire Color | P1 | Wire Color | P2 | Wire Color | P1 | Wire Color | P2 |
|------------|----|------------|----|------------|----|------------|----|
| Wht/blu    | 1  | Wht/blu    | 1  | Grn/blk    | 38 | Grn/blk    | 38 |
| Blu/wht    | 26 | Blu/wht    | 26 | Blk/brn    | 14 | Blk/brn    | 14 |
| Wht/org    | 2  | Wht/org    | 2  | Brn/blk    | 39 | Brn/blk    | 39 |

Table B-2 Standard Telco Color Chart (continued)

| Wire Color | P1 | Wire Color | P2 | Wire Color | P1 | Wire Color | P2 |
|------------|----|------------|----|------------|----|------------|----|
| Org/wht    | 27 | Org/wht    | 27 | Blk/gry    | 15 | Blk/gry    | 15 |
| Wht/grn    | 3  | Wht/grn    | 3  | Gry/blk    | 40 | Gry/blk    | 40 |
| Grn/wht    | 28 | Grn/wht    | 28 | Yel/blu    | 16 | Yel/blu    | 16 |
| Wht/brn    | 4  | Wht/brn    | 4  | Blu/yel    | 41 | Blu/yel    | 41 |
| Brn/wht    | 29 | Brn/wht    | 29 | Yel/org    | 17 | Yel/org    | 17 |
| Wht/gry    | 5  | Wht/gry    | 5  | Org/yel    | 42 | Org/yel    | 42 |
| Gry/wht    | 30 | Gry/wht    | 30 | Yel/grn    | 18 | Yel/grn    | 18 |
| Red/blu    | 6  | Red/blu    | 6  | Grn/yel    | 43 | Grn/yel    | 43 |
| Blu/red    | 31 | Blu/red    | 31 | Yel/brn    | 19 | Yel/brn    | 19 |
| Red/org    | 7  | Red/org    | 7  | Brn/yel    | 44 | Brn/yel    | 44 |
| Org/red    | 32 | Org/red    | 32 | Yel/gry    | 20 | Yel/gry    | 20 |
| Red/grn    | 8  | Red/grn    | 8  | Gry/yel    | 45 | Gry/yel    | 45 |
| Grn/red    | 33 | Grn/red    | 33 | Vio/blu    | 21 | Vio/blu    | 21 |
| Red/brn    | 9  | Red/brn    | 9  | Blu/vio    | 46 | Blu/vio    | 46 |
| Brn/red    | 34 | Brn/red    | 34 | Vio/org    | 22 | Vio/org    | 22 |
| Red/gry    | 10 | Red/gry    | 10 | Org/vio    | 47 | Org/vio    | 47 |
| Gry/red    | 35 | Gry/red    | 35 | Vio/grn    | 23 | Vio/grn    | 23 |
| Blk/blu    | 11 | Blk/blu    | 11 | Grn/vio    | 48 | Grn/vio    | 48 |
| Blu/blk    | 36 | Blu/blk    | 36 | Vio/brn    | 24 | Vio/brn    | 24 |
| Blk/org    | 12 | Blk/org    | 12 | Brn/vio    | 49 | Brn/vio    | 49 |
| Org/blk    | 37 | Org/blk    | 37 | Vio/gry    | 25 | Vio/gry    | 25 |
| Blk/grn    | 13 | Blk/grn    | 13 | Gry/vio    | 50 | Gry/vio    | 50 |







## Connector and Pinout Specifications

This appendix provides information about connectors and pinouts for configuration of the Cisco 6260 system.

### C.1 xDSL Connectors

Ten female RJ-21 (Champ) subscriber connectors are located at the top of the Cisco 6260 chassis, facing forward. These 50-pin sockets provide the DSL subscriber connections. Each subscriber connector serves three line card slots. This connection can be made by either of the following methods:

- Through a POTS splitter for voice and data applications (Cisco 6260 with a POTS splitter configuration)
- Directly for data only applications (Cisco 6260 without a POTS splitter configuration)

Figure C-1 shows connector pin locations for the xDSL Champ connectors. Pin locations are the same for all Champ connectors.

**Figure C-1** xDSL Connector Pin Locations

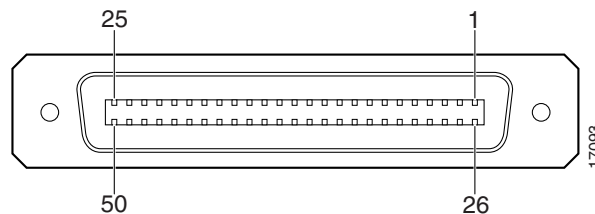

### C.2 I/O Module Connectors

This section provides information about the external interface connectors for the Cisco 6260 I/O module.

## C.2.1 E3 I/O Module BNC Connectors

Three sets of two vertically paired E3 75-ohm coaxial BNC connectors reside on the left side of the I/O module faceplate. The P1 connectors serve as the network trunk connections. The P2 and P3 connectors support subtending to additional Cisco 6260 chassis. Each set has both a receive (RX) connector and a transmit (TX) connector.

Figure C-2 shows a close-up of the E3 connectors.

**Figure C-2** BNC Connectors on the E3 I/O Module

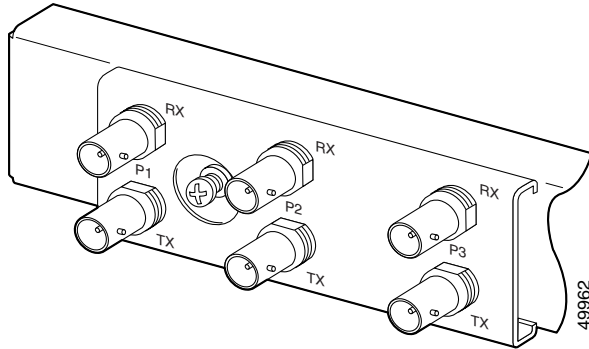

## C.2.2 E1 I/O Module RJ-48c Connectors

Four sets of two vertically paired E1120-ohm RJ-48c connectors are located on the left side of the I/O module faceplate. Each E1 interface can be used as a WAN trunk connection, an individual E1 subtend link, a connection to an IMA subtending group, or a connection to an IMA group trunk interface.

Figure C-3 shows a close-up of the E1 connectors.

**Figure C-3** RJ-48c Connectors on the E1 I/O Module

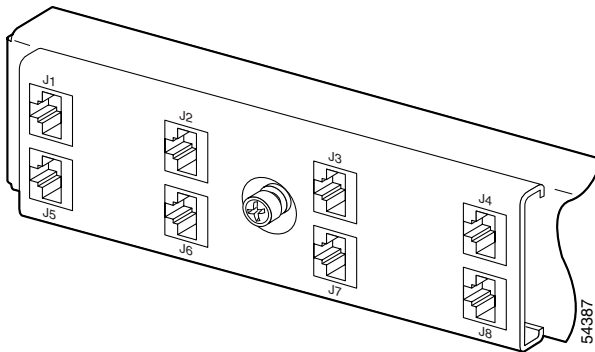

## C.3 I/O Module Wire-Wrap Pins

There are 36 wire-wrap pins located on the right side of each I/O module faceplate that support

- Central office alarm relay interfaces (visual and audible critical, major, and minor)
- BITS clock input circuits
- Wire-wrap and socket-type connections

Table C-1 lists the pinout descriptions for the I/O module wire-wrap pins and Figure C-4 shows a close-up of the I/O module wire-wrap pins.

**Table C-1 I/O Module Wire-Wrap Pin Mapping**

| Pin | Row 1                                  | Row 2                                   | Row 3                    | Row 4                                  | Row 5    | Row 6                      |
|-----|----------------------------------------|-----------------------------------------|--------------------------|----------------------------------------|----------|----------------------------|
| 1   | PEM <sup>1</sup> 1_BR <sup>2</sup> _CO | AUD <sup>3</sup> _CRIT <sup>4</sup> _CO | AUD_MIN <sup>5</sup> _CO | VIS <sup>6</sup> _MAJ <sup>7</sup> _CO | Reserved | RX_BITS <sup>8</sup> _TIPA |
| 2   | PEM1_BR_NO                             | AUD_CRIT_NO                             | AUD_MIN_NO               | VIS_MAJ_NO                             | Reserved | RX_BITS_RINGA              |
| 3   | PEM1_BR_NC                             | AUD_CRIT_NC                             | AUD_MIN_NC               | VIS_MAJ_NC                             | Reserved | RX_BITS_GND/GND            |
| 4   | PEM2_BR_CO                             | AUD_MAJ_CO                              | VIS_CRIT_CO              | VIS_MIN_CO                             | Reserved | RX_BITS_TIPB               |
| 5   | PEM2_BR_NO                             | AUD_MAJ_NO                              | VIS_CRIT_NO              | VIS_MIN_NO                             | ACO_NO   | RX_BITS_RINGB              |
| 6   | PEM2_BR_NC                             | AUD_MAJ_NC                              | VIS_CRIT_NC              | VIS_MIN_NC                             | GND      | RX_BITS_GND/GND            |

1. PEM = power entry module
2. BR = breaker
3. AUD = audible
4. CRIT = critical alarm
5. MIN = minor alarm
6. VIS = visible
7. MAJ = major alarm
8. RX\_BITS = receive building-integrated timing source

**Figure C-4 I/O Module Wire-Wrap Pins Close-Up**

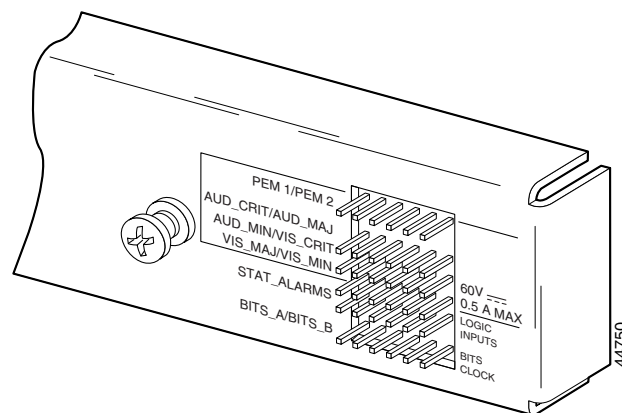

## C.4 Console and Auxiliary Ports

The console and auxiliary ports, which are two identical serial EIA/TIA-232 ports, use RJ-48 receptacle connectors on the NI-2 card faceplate. Table C-2 shows the pin assignments, and Figure C-5 shows an RJ-48 receptacle connector.

**Table C-2** Pin Assignments for the NI-2 Card Console and Auxiliary Connectors

| Pin Number | Signal |
|------------|--------|
| 1          | RTS    |
| 2          | DTR    |
| 3          | TXD    |
| 4          | GND    |
| 5          | GND    |
| 6          | RXD    |
| 7          | DSR    |
| 8          | CTS    |

**Figure C-5** NI-2 Card Console and Auxiliary Connector

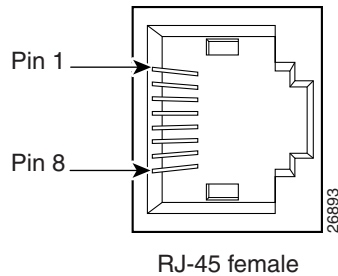

## C.5 Ethernet Port

The Ethernet port, a 10BaseT interface with an RJ-48 receptacle connector, is on the NI-2 card faceplate. It is used to connect the Cisco 6260 to the management station, a Sun SPARCstation running Cisco DSL Manager (CDM) software. Table C-3 shows the pin assignments, and Figure C-6 shows an NI-2 card Ethernet connector.

**Table C-3 Pin Assignments for the NI-2 Card Management Ethernet Connector**

| Pin Number | Signal |
|------------|--------|
| 1          | TX+    |
| 2          | TX-    |
| 3          | RX+    |
| 4          | Unused |
| 5          | Unused |
| 6          | RX-    |
| 7          | Unused |
| 8          | Unused |

**Figure C-6 NI-2 Card Management Ethernet Connector**

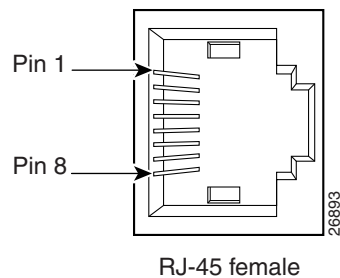





## GLOSSARY

---

### Numerics

- 2B1Q** 2 binary 1 quaternary. An encoding scheme that provides a 2 bits per baud, 80k baud per second, 160kbps transfer rate. The most common signaling method on ISDN U interfaces.
- 4xflexi** quad-port flexi ATU-C line card. Supports four ADSL modem connections and CAP, DMT, and G.lite line encoding. For chassis compatibility, refer to the *Cisco DSLAM Compatibility Notes* or the appropriate hardware installation guide.
- 4xSDSL** quad-port STU-C line card. Supports four SDSL modem connections and 2B1Q line encoding. For chassis compatibility, refer to the *Cisco DSLAM Compatibility Notes* or the appropriate hardware installation guide.
- 8xDMT** octal-port DMT ATU-C line card. Supports eight ADSL modem connections and DMT line encoding. For chassis compatibility, refer to the *Cisco DSLAM Compatibility Notes* or the appropriate hardware installation guide.
- 8xG.SHDSL** octal-port SHTU-C line card. Supports eight G.SHDSL modem connections and TC-PAM line encoding. For chassis compatibility, refer to the *Cisco DSLAM Compatibility Notes* or the appropriate hardware installation guide.
- 8xIDSL** octal-port ITU-C line card. Supports eight IDSL modem connections, or four connections when the chassis limits the number of tip and ring connectors. Supports 2B1Q line encoding. For chassis compatibility, refer to the *Cisco DSLAM Compatibility Notes* or the appropriate hardware installation guide.

---

### A

- AAL** ATM adaptation layer. AAL is an adaptation layer within the data link layer of the OSI model. AAL is divided into a segmentation and reassembly sublayer (SAR) and a convergence sublayer. The SAR divides the application datastream into transmit cells and then reassembles the received cells into a datastream that is compatible with the related application. The convergence sublayer specifies the requirements for the various types of applications that run over ATM. AAL is defined in terms of types, 1 to 5, specified by the type of traffic that it supports. Each type offers an appropriate QoS.
- ABR** available bit rate. A QoS class defined by the ATM Forum for ATM networks. ABR is used for connections that do not require timing relationships between source and destination. ABR provides no guarantees in terms of cell loss or delay, providing only best-effort service. Traffic sources adjust their transmission rate in response to information they receive describing the status of the network and its capability to successfully deliver data. Compare with *CBR*, *UBR*, and *VBR*.

|                                              |                                                                                                                                                                                                                                                                                                                                                    |
|----------------------------------------------|----------------------------------------------------------------------------------------------------------------------------------------------------------------------------------------------------------------------------------------------------------------------------------------------------------------------------------------------------|
| <b>accounting management</b>                 | One of five categories of network management defined by ISO for the management of ISO networks. Accounting management subsystems are responsible for collecting network data that relates to resource usage. See also <i>configuration management</i> , <i>fault management</i> , <i>performance management</i> , and <i>security management</i> . |
| <b>address</b>                               | Data structure or logical convention used to identify a unique entity, such as a particular process or network device.                                                                                                                                                                                                                             |
| <b>ADSL</b>                                  | asymmetric digital subscriber line. An xDSL technology in which more bandwidth is delivered downstream (from the CO to the customer site) than upstream over a single copper twisted pair. Compare with <i>IDSL</i> , <i>SDSL</i> , and <i>SHDSL</i> . See also <i>DSL</i> .                                                                       |
| <b>alarm</b>                                 | A notification that a traffic signal has degraded or failed or that equipment is malfunctioning. See also <i>event</i> and <i>trap</i> .                                                                                                                                                                                                           |
| <b>AM</b>                                    | amplitude modulation. A modulation technique by which information is conveyed through the amplitude of the carrier signal. Compare with <i>FM</i> and <i>PAM</i> . See also <i>modulation</i> .                                                                                                                                                    |
| <b>American National Standards Institute</b> | See <i>ANSI</i> .                                                                                                                                                                                                                                                                                                                                  |
| <b>American Wire Gauge</b>                   | See <i>AWG</i> .                                                                                                                                                                                                                                                                                                                                   |
| <b>amplitude modulation</b>                  | See <i>AM</i> .                                                                                                                                                                                                                                                                                                                                    |
| <b>ANSI</b>                                  | American National Standards Institute. An organization that coordinates, develops, and approves international and U.S. standards for, among other things, communications and networking. ANSI is a member of ISO. See also <i>ISO</i> .                                                                                                            |
| <b>APS</b>                                   | automatic protection switching. A method that allows transmission equipment to recover automatically from failures, such as a cut cable.                                                                                                                                                                                                           |
| <b>asymmetric digital subscriber line</b>    | See <i>ADSL</i> .                                                                                                                                                                                                                                                                                                                                  |
| <b>asynchronous communications</b>           | A method of transmitting data in which individual characters are encapsulated in control bits (called start and stop bits) that designate the beginning and end of each character. Asynchronous transmission allows communication without precise clocking.                                                                                        |
| <b>Asynchronous Transfer Mode</b>            | See <i>ATM</i> .                                                                                                                                                                                                                                                                                                                                   |
| <b>ATM</b>                                   | Asynchronous Transfer Mode. The international standard for cell relay in which multiple service types (voice, video, or data, for example) are transmitted in fixed-length (53-byte) cells. ATM offers fast packet technology, and real-time, demand-led switching for efficient use of network resources.                                         |
| <b>ATM adaptation layer</b>                  | See <i>AAL</i> .                                                                                                                                                                                                                                                                                                                                   |
| <b>ATU-C</b>                                 | See <i>xTU-C</i> .                                                                                                                                                                                                                                                                                                                                 |
| <b>ATU-R</b>                                 | See <i>xTU-R</i> .                                                                                                                                                                                                                                                                                                                                 |



|                                       |                                                                                                                                                                                                  |
|---------------------------------------|--------------------------------------------------------------------------------------------------------------------------------------------------------------------------------------------------|
| <b>authentication</b>                 | In security, the verification of the identity of a person or a process.                                                                                                                          |
| <b>autodiscovery</b>                  | The process by which a network device automatically searches through a range of network addresses and discovers the known types of devices that are present. Also see <i>subrack discovery</i> . |
| <b>automatic protection switching</b> | See <i>APS</i> .                                                                                                                                                                                 |
| <b>available bit rate</b>             | See <i>ABR</i> .                                                                                                                                                                                 |
| <b>AWG</b>                            | American Wire Gauge. The standard gauge for measurement of thickness of a wire in the United States.                                                                                             |

---

**B**

|                                       |                                                                                                                                                                                                                                                                                                                                                 |
|---------------------------------------|-------------------------------------------------------------------------------------------------------------------------------------------------------------------------------------------------------------------------------------------------------------------------------------------------------------------------------------------------|
| <b>backplane</b>                      | The physical connection between an interface processor or card and the data buses and the power distribution buses inside a DSLAM.                                                                                                                                                                                                              |
| <b>bandwidth</b>                      | The difference between the highest and lowest frequencies available for network signals. The term also is used to describe the rated throughput capacity of a given network medium or protocol. For a digital channel, this is defined in bits. For an analog channel, it depends on the type and method of modulation used to encode the data. |
| <b>bandwidth on demand</b>            | The ability of a user to dynamically set upstream and downstream line speeds to a particular rate of speed.                                                                                                                                                                                                                                     |
| <b>BITS</b>                           | building integrated timing supply. A clock in a CO that supplies DS1 or composite clock timing references to all synchronous network elements in that office.                                                                                                                                                                                   |
| <b>bits per second</b>                | See <i>bps</i> .                                                                                                                                                                                                                                                                                                                                |
| <b>bootflash</b>                      | Separate Flash memory device used primarily to store the Cisco IOS boot image, operational Cisco IOS images, and system configuration information.                                                                                                                                                                                              |
| <b>BOOTP</b>                          | Bootstrap Protocol. The protocol used by a network node to determine the IP address of its Ethernet interfaces to affect network booting.                                                                                                                                                                                                       |
| <b>Bootstrap Protocol</b>             | See <i>BOOTP</i> .                                                                                                                                                                                                                                                                                                                              |
| <b>bps</b>                            | bits per second. A standard measurement of digital transmission speeds.                                                                                                                                                                                                                                                                         |
| <b>bridge</b>                         | A device that connects two or more physical networks and forwards packets between them. Bridges can usually be made to filter packets, that is, to forward only certain traffic. See <i>switch</i> and <i>router</i> .                                                                                                                          |
| <b>broadband</b>                      | In telecommunications, any channel having a bandwidth greater than a voice-grade channel (4 kHz).                                                                                                                                                                                                                                               |
| <b>broadband remote access server</b> | Device that terminates remote users at the corporate network or Internet users at the internet service provider (ISP) network that provides firewall, authentication, and routing services for remote users.                                                                                                                                    |
| <b>broadcast</b>                      | Data packet that are sent to all nodes on a network. Broadcasts are identified by a broadcast address. Compare with <i>multicast</i> and <i>unicast</i> .                                                                                                                                                                                       |

**building integrated timing supply** See *BITS*.

**bus topology** A linear method of connecting devices so that transmissions from network stations propagate the length of the medium and are received by all other stations. Compare with *daisy-chain topology*, *ring topology*, *star topology*, and *tree topology*.

---

## C

**CAP** Carrierless Amplitude and Phase Modulation. A bandwidth efficient transmission technology for implementing DSL. The transmit and receive signals are modulated into two wide-frequency bands using passband modulation techniques. CAP supports ADSL and RADSL line coding.

**Carrierless Amplitude and Phase Modulation** See *CAP*.

**CBOS** Cisco Broadband Operating System. The operating system that users access to configure and operate the Cisco 600 Series DSL CPE products.

**CBR** constant bit rate. A QoS class defined by the ATM Forum for ATM networks. CBR is used for connections that depend on precise clocking to ensure undistorted delivery. Compare with *ABR*, *UBR*, and *VBR*.

**CDM** Cisco DSL Manager. An SNMP-based element management system with fault, configuration, and performance reporting capabilities. CDM runs within the Cisco EMF and manages DSLAMs through a GUI.

**central office** See *CO*.

**chassis** The cage or housing into which cards or modules are installed. See also *DSLAM* and *multiplexer*.

**child** See *subtended node chassis*.

**Cisco Broadband Operating System** See *CBOS*.

**Cisco DSL Manager** See *CDM*.

**Cisco Element Management Framework** See *Cisco EMF*.

**Cisco EMF** Cisco Element Management Framework. The element management layer of the system. Cisco EMF provides the framework to support carrier-class element managers across Cisco service provider product lines.

**Cisco IOS** Cisco system software that provides common functionality, scalability, and security for all products under the CiscoFusion architecture. Cisco IOS is a CLI that allows centralized, integrated, and automated installation and management of internetworks while ensuring support for a wide variety of protocols, media, services, and platforms.

|                                             |                                                                                                                                                                                                                                                                                                                                               |
|---------------------------------------------|-----------------------------------------------------------------------------------------------------------------------------------------------------------------------------------------------------------------------------------------------------------------------------------------------------------------------------------------------|
| <b>Cisco Service Management</b>             | See <i>CSM</i> .                                                                                                                                                                                                                                                                                                                              |
| <b>CLEI</b>                                 | common language equipment identifier. The standard code used by suppliers to identify equipment parts and system configurations. CLEI is a registered trademark of Bellcore (now Telcordia).                                                                                                                                                  |
| <b>CLI</b>                                  | command line interface. An interface that allows the user to interact with the operating system by entering commands and optional arguments.                                                                                                                                                                                                  |
| <b>client</b>                               | Node or software program (front-end device) that requests services from a server.                                                                                                                                                                                                                                                             |
| <b>CO</b>                                   | central office. A local telephone company office at all local loops in a given area connect and where the circuit switching of subscriber lines occurs.                                                                                                                                                                                       |
| <b>command line interface</b>               | See <i>CLI</i> .                                                                                                                                                                                                                                                                                                                              |
| <b>common language equipment identifier</b> | See <i>CLEI</i> .                                                                                                                                                                                                                                                                                                                             |
| <b>community string</b>                     | Text string that acts as a password used with SNMP protocol. The password is used to authenticate messages and can be read-only or have read/write privileges; setting it to read-only is private and setting it to read-write is public. A community string is case sensitive.                                                               |
| <b>configuration management</b>             | One of five categories of network management defined by ISO for the management of OSI networks. Configuration management subsystems are responsible for detecting and determining the state of a network. See also <i>accounting management</i> , <i>fault management</i> , <i>performance management</i> , and <i>security management</i> .  |
| <b>configuration register</b>               | In Cisco DSLAMs, a 16-bit, user-configurable value that determines how the DSLAM functions during initialization. The configuration register can be stored in hardware or software. In hardware, the bit position is set using a jumper. In software, the bit position is set by specifying a hexadecimal value using configuration commands. |
| <b>connectionless network</b>               | A type of communications network in which no logical connection (for example, no leased line or dialed-up channel) is required between sending and receiving stations. Compare with <i>connection-oriented network</i> .                                                                                                                      |
| <b>connection-oriented network</b>          | A type of communications network in which data transfer requires the establishment of a virtual circuit. Compare with <i>connectionless network</i> .                                                                                                                                                                                         |
| <b>constant bit rate</b>                    | See <i>CBR</i> .                                                                                                                                                                                                                                                                                                                              |
| <b>CPE</b>                                  | customer premises equipment. Terminating equipment, such as terminals, telephones, and modems, supplied by the telephone company. The equipment is installed at customer sites and connected to the telephone company network.                                                                                                                |
| <b>CSM</b>                                  | Cisco Service Management system of OAM&P and management tools for service providers and large enterprise networks.                                                                                                                                                                                                                            |
| <b>customer premises equipment</b>          | See <i>CPE</i> .                                                                                                                                                                                                                                                                                                                              |

---

**D**

|                                                   |                                                                                                                                                                                                                                                                                                                                                                                                                                 |
|---------------------------------------------------|---------------------------------------------------------------------------------------------------------------------------------------------------------------------------------------------------------------------------------------------------------------------------------------------------------------------------------------------------------------------------------------------------------------------------------|
| <b>daemon</b>                                     | A program that is not invoked explicitly but lies dormant waiting for some condition(s) to occur.                                                                                                                                                                                                                                                                                                                               |
| <b>daisy-chain topology</b>                       | A method of connecting devices in a series so that signals are passed through the chain from one device to the next. Unlike a ring topology, the last device in the series is not connected to the first. Compare with <i>bus topology</i> , <i>ring topology</i> , <i>star topology</i> , and <i>tree topology</i> .                                                                                                           |
| <b>data circuit-terminating equipment</b>         | See <i>DCE</i> .                                                                                                                                                                                                                                                                                                                                                                                                                |
| <b>data storage backup</b>                        | Process of making a copy of the data that resides on a server.                                                                                                                                                                                                                                                                                                                                                                  |
| <b>data terminal equipment</b>                    | See <i>DTE</i> .                                                                                                                                                                                                                                                                                                                                                                                                                |
| <b>DCE</b>                                        | Data circuit-terminating equipment (ITU-T expansion). Devices and connections of a communications network that comprise the network end of the user-to-network interface. The DCE provides a physical connection to the network, forwards traffic, and provides a clocking signal used to synchronize data transmissions between DCE and DTE devices. Modems and interface cards are examples of DCE. Compare with <i>DTE</i> . |
| <b>DDTS</b>                                       | Distributed Defect Tracking System. Cisco tracks bugs in a variety of products, including router software, communication server software, and network management software, using a system called DDTS. DDTS is also used for bugs in some hardware and microcode products, and for bugs in some internal tools, including the automated test software and various Software Tools.                                               |
| <b>destination address</b>                        | Address of a network device that is receiving data. See also <i>source address</i> .                                                                                                                                                                                                                                                                                                                                            |
| <b>DHCP</b>                                       | Dynamic Host Configuration Protocol. Provides a mechanism to allocate IP addresses dynamically so that addresses can be reused when hosts no longer need them. Defined in RFC 2131.                                                                                                                                                                                                                                             |
| <b>digital signal level 3</b>                     | See <i>DS3</i> .                                                                                                                                                                                                                                                                                                                                                                                                                |
| <b>digital subscriber line</b>                    | See <i>DSL</i> .                                                                                                                                                                                                                                                                                                                                                                                                                |
| <b>digital subscriber line access multiplexer</b> | See <i>DSLAM</i> .                                                                                                                                                                                                                                                                                                                                                                                                              |
| <b>Discrete Multitone</b>                         | See <i>DMT</i> .                                                                                                                                                                                                                                                                                                                                                                                                                |
| <b>Distributed Defect Tracking System</b>         | See <i>DDTS</i> .                                                                                                                                                                                                                                                                                                                                                                                                               |
| <b>distributed server</b>                         | Server that supports a specific group of users on the network. Also referred to as local or workgroup server.                                                                                                                                                                                                                                                                                                                   |
| <b>DMT</b>                                        | Discrete Multitone. A technology that uses digital signal processors to transmit more than 6 Mbps of video, data, image, and voice signals over existing one pair copper wiring. DMT supports ADSL line coding.                                                                                                                                                                                                                 |

|                                            |                                                                                                                                                                                                                                                                                                                                                                                                                                                                                                                                |
|--------------------------------------------|--------------------------------------------------------------------------------------------------------------------------------------------------------------------------------------------------------------------------------------------------------------------------------------------------------------------------------------------------------------------------------------------------------------------------------------------------------------------------------------------------------------------------------|
| <b>downstream</b>                          | Data that is coming from the NI-2 card to the subscriber lines. See also <i>upstream</i> .                                                                                                                                                                                                                                                                                                                                                                                                                                     |
| <b>DS3</b>                                 | digital signal level 3. A framing specification used for transmitting digital signals at 44.736 Mbps on a T3 facility. See also <i>E3</i> .                                                                                                                                                                                                                                                                                                                                                                                    |
| <b>DSL</b>                                 | digital subscriber line. Public network technology that delivers high bandwidth over conventional copper wiring at limited distances. There are several types of DSL: ADSL, IDSL, SDSL, and SHDSL, to name a few. All are provisioned via modem pairs, with one modem located at a CO and the other at the customer site. Because most DSL technologies do not use the whole bandwidth of the twisted pair, there is room remaining for a voice channel. See also <i>ADSL</i> , <i>IDSL</i> , <i>SDSL</i> , and <i>SHDSL</i> . |
| <b>DSL Forum</b>                           | An organization of competing companies that sponsors an Internet Web site ( <a href="http://www.adsl.com">http://www.adsl.com</a> ) containing information about the applications, technology, systems, market, trials, and tariffs related to DSL technology.                                                                                                                                                                                                                                                                 |
| <b>DSLAM</b>                               | digital subscriber line access multiplexer. A device that connects many digital subscriber lines to a network by multiplexing the DSL traffic onto one or more network trunk lines. The Cisco DSLAMs include the Cisco 6015, Cisco 6100, Cisco 6130, Cisco 6160, and Cisco 6260. See also <i>chassis</i> and <i>multiplexer</i> .                                                                                                                                                                                              |
| <b>DTE</b>                                 | data terminal equipment. Device at the user end of a user-network interface that serves as a data source, destination, or both. DTE connects to a data network through a DCE device (for example, a modem) and typically uses clocking signals generated by the DCE. DTE includes such devices as computers, protocol translators, and multiplexers. Compare with <i>DCE</i> .                                                                                                                                                 |
| <b>Dynamic Host Configuration Protocol</b> | See <i>DHCP</i> .                                                                                                                                                                                                                                                                                                                                                                                                                                                                                                              |
| <hr/>                                      |                                                                                                                                                                                                                                                                                                                                                                                                                                                                                                                                |
| <b>E</b>                                   |                                                                                                                                                                                                                                                                                                                                                                                                                                                                                                                                |
| <b>E1</b>                                  | Wide-area digital transmission scheme used predominantly in Europe that carries data at a rate of 2.048 Mbps. See also <i>T1</i> .                                                                                                                                                                                                                                                                                                                                                                                             |
| <b>E3</b>                                  | Wide-area digital transmission scheme used predominantly in Europe that carries data at a rate of 34.368 Mbps. See also <i>DS3</i> and <i>T3</i> .                                                                                                                                                                                                                                                                                                                                                                             |
| <b>EFCI</b>                                | explicit forward congestion indication. In ATM, one of the congestion feedback modes allowed by ABR service. EFCI is set by a network element to notify the destination end-system of congestion or impending congestion in the network.                                                                                                                                                                                                                                                                                       |
| <b>EIA</b>                                 | Electronic Industries Alliance. A standards organization made up of electronics industry organizations. EIA is responsible for the RS-232C and RS-422 standards.                                                                                                                                                                                                                                                                                                                                                               |
| <b>Electronic Industries Alliance</b>      | See <i>EIA</i> .                                                                                                                                                                                                                                                                                                                                                                                                                                                                                                               |
| <b>electrostatic discharge</b>             | See <i>ESD</i> .                                                                                                                                                                                                                                                                                                                                                                                                                                                                                                               |

|                                                        |                                                                                                                                                                                                                                                                                                                  |
|--------------------------------------------------------|------------------------------------------------------------------------------------------------------------------------------------------------------------------------------------------------------------------------------------------------------------------------------------------------------------------|
| <b>encapsulation</b>                                   | The wrapping of data in a particular protocol header. For example, Ethernet data is wrapped in a specific Ethernet header before network transit. Also, when bridging a dissimilar network, the entire frame from one network is placed in the header used by the data link layer protocol of the other network. |
| <b>EPROM</b>                                           | Erasable programmable read-only memory. Nonvolatile memory chips that are programmed after they are manufactured, and, if necessary, can be erased by some means and reprogrammed.                                                                                                                               |
| <b>erasable programmable read-only memory</b>          | See <i>EPROM</i> .                                                                                                                                                                                                                                                                                               |
| <b>error detection</b>                                 | A process used during file transfer to discover discrepancies between transmitted and received data. Some file transfer programs only detect errors; others detect errors and attempt to fix them (called error correction).                                                                                     |
| <b>ESD</b>                                             | electrostatic discharge. Discharge of stored static electricity that can damage electronic equipment and impair electrical circuitry, resulting in complete or intermittent failures.                                                                                                                            |
| <b>ESF</b>                                             | Extended Superframe. A framing type that is used on T1 circuits that consists of 24 frames of 192 bits each, with the 193rd bit providing timing and other functions.                                                                                                                                            |
| <b>Ethernet</b>                                        | One of the most common LAN wiring schemes, Ethernet has a transmission rate of 10 Mbps; a newer standard called Fast Ethernet has a rate of 100 Mbps.                                                                                                                                                            |
| <b>ETSI</b>                                            | European Telecommunications Standards Institute. ETSI is a non-profit organization producing voluntary telecommunications standards used throughout Europe, some of which have been adopted by the European community as the technical base for Directives or Regulations.                                       |
| <b>European Telecommunications Standards Institute</b> | See <i>ETSI</i> .                                                                                                                                                                                                                                                                                                |
| <b>event</b>                                           | Network message indicating operational irregularities in physical elements of a network or a response to the occurrence of a significant task, typically the completion of a request for information. See also <i>alarm</i> and <i>trap</i> .                                                                    |
| <b>explicit forward congestion indication</b>          | See <i>EFCT</i> .                                                                                                                                                                                                                                                                                                |
| <b>Extended Superframe</b>                             | See <i>ESF</i> .                                                                                                                                                                                                                                                                                                 |

---

**F**

|                         |                                                                                                                                                                                                                                                                                                                             |
|-------------------------|-----------------------------------------------------------------------------------------------------------------------------------------------------------------------------------------------------------------------------------------------------------------------------------------------------------------------------|
| <b>fault management</b> | One of five categories of network management defined by ISO for management of OSI networks. Fault management attempts to ensure that network faults are detected and controlled. See also <i>accounting management</i> , <i>configuration management</i> , <i>performance management</i> , and <i>security management</i> . |
|-------------------------|-----------------------------------------------------------------------------------------------------------------------------------------------------------------------------------------------------------------------------------------------------------------------------------------------------------------------------|

|                                          |                                                                                                                                                                                                                                                            |
|------------------------------------------|------------------------------------------------------------------------------------------------------------------------------------------------------------------------------------------------------------------------------------------------------------|
| <b>FCC</b>                               | Federal Communications Commission. A U.S. government agency that regulates interstate and foreign communications. The FCC sets rates for communication services, determines standards for equipment, and controls broadcast licensing.                     |
| <b>Federal Communications Commission</b> | See <i>FCC</i> .                                                                                                                                                                                                                                           |
| <b>ferrite</b>                           | Use on coaxial cables to reduce the radiation/EMI susceptibility to high frequency noise.                                                                                                                                                                  |
| <b>field replaceable unit</b>            | See <i>FRU</i> .                                                                                                                                                                                                                                           |
| <b>File Transfer Protocol</b>            | See <i>FTP</i> .                                                                                                                                                                                                                                           |
| <b>firmware</b>                          | Software instructions set permanently or semi-permanently in ROM.                                                                                                                                                                                          |
| <b>flash memory</b>                      | A special type of EPROM that can be used and reprogrammed in blocks instead of one byte at a time.                                                                                                                                                         |
| <b>FM</b>                                | frequency modulation. Modulation technique in which signals of different frequencies represent different data values. Compare with <i>AM</i> and <i>PAM</i> . See also <i>modulation</i> .                                                                 |
| <b>frame</b>                             | A packet as it is transmitted over a serial line. The term derives from character-oriented protocols that involved the addition of special start-of-frame and end-of-frame characters for packet transmission.                                             |
| <b>frequency modulation</b>              | See <i>FM</i> .                                                                                                                                                                                                                                            |
| <b>FRU</b>                               | field replaceable unit. Hardware component that can be removed and replaced on-site. Typical FRUs include cards, modules, PEMs, and some chassis components. When FRUs are removed from the chassis, service is interrupted for some or all of the system. |
| <b>FTP</b>                               | File Transfer Protocol. The application protocol used to transfer files between network nodes.                                                                                                                                                             |

---

**G**

|                |                                                                                                                                                                             |
|----------------|-----------------------------------------------------------------------------------------------------------------------------------------------------------------------------|
| <b>G.992.1</b> | Also known as <i>G.dmt</i> .                                                                                                                                                |
| <b>G.992.2</b> | The ITU standard for line coding and framing for splitterless, reduced spectrum ADSL. Also known as <i>G.lite</i> .                                                         |
| <b>G.994.1</b> | The ITU standard for signaling, identification, and negotiation between broadband systems; an integral part of <i>G.dmt</i> and <i>G.lite</i> . Also known as <i>G.hs</i> . |
| <b>G.997.1</b> | The ITU standard for performance monitoring on DMT access technologies.                                                                                                     |
| <b>G.dmt</b>   | Pseudonym for <i>G.992.1</i> .                                                                                                                                              |
| <b>G.hs</b>    | Pseudonym for <i>G.994.1</i> .                                                                                                                                              |
| <b>G.lite</b>  | Pseudonym for <i>G.992.2</i> .                                                                                                                                              |

|                                 |                                                                                                                                                                                                                              |
|---------------------------------|------------------------------------------------------------------------------------------------------------------------------------------------------------------------------------------------------------------------------|
| <b>G.SHDSL</b>                  | See <i>SHDSL</i> .                                                                                                                                                                                                           |
| <b>graphical user interface</b> | See <i>GUI</i> .                                                                                                                                                                                                             |
| <b>GUI</b>                      | graphical user interface. A user environment that uses pictorial as well as textual representations of the input and the output of applications and the hierarchical or other data structure in which information is stored. |

---

## H

|                                     |                                                                                                                                                                                                                                                                                                                                                         |
|-------------------------------------|---------------------------------------------------------------------------------------------------------------------------------------------------------------------------------------------------------------------------------------------------------------------------------------------------------------------------------------------------------|
| <b>handshake</b>                    | See <i>hs</i> .                                                                                                                                                                                                                                                                                                                                         |
| <b>HDLC</b>                         | High-Level Data Link Control. Bit-oriented synchronous data link layer protocol developed by ISO. Derived from Synchronous Data Link Control (SDLC), HDLC specifies a data encapsulation method on synchronous serial links using frame characters and checksums.                                                                                       |
| <b>header</b>                       | (1) The protocol control information that is located at the beginning of a protocol data unit. (2) The portion of a message that contains information to guide the message to the correct destination and contains, for example, sender and receiver addresses and routing instructions.                                                                |
| <b>High-Level Data Link Control</b> | See <i>HDLC</i> .                                                                                                                                                                                                                                                                                                                                       |
| <b>host</b>                         | Computer system on a network. Similar to the term node, except that host usually implies a computer system; node generally applies to any networked system, including access servers and routers. See also <i>node</i> .                                                                                                                                |
| <b>hot swapping</b>                 | Feature that permits the addition, replacement, or removal of cards or modules without interrupting the system power, entering console commands, or causing other software or interfaces to shut down. Sometimes called “online insertion and removal” or “power-on servicing.” Removal of some cards causes interruption to some or all of the system. |
| <b>hs</b>                           | handshake. Sequence of messages that are exchanged between two or more network devices to ensure transmission synchronization.                                                                                                                                                                                                                          |

---

## I

|                               |                                                                                                                                                                                                                                                                                             |
|-------------------------------|---------------------------------------------------------------------------------------------------------------------------------------------------------------------------------------------------------------------------------------------------------------------------------------------|
| <b>I/O card or I/O module</b> | input/output card or module.                                                                                                                                                                                                                                                                |
| <b>ICP cell</b>               | IMA control protocol cell. IMA control protocol cell used for aligning the cells in multiple links.                                                                                                                                                                                         |
| <b>IDSL</b>                   | ISDN digital subscriber line. An xDSL technology that uses ISDN technology to deliver data at speeds of 128 Kbps over copper loops as long as 18,000 feet. IDSL is reserved for data communications only. Compare with <i>ADSL</i> , <i>SDSL</i> , and <i>SHDSL</i> . See also <i>DSL</i> . |
| <b>IEEE</b>                   | Institute of Electrical and Electronics Engineers. A U.S. publishing and standards organization responsible for many LAN standards.                                                                                                                                                         |



|                                                                                       |                                                                                                                                                                                                                     |
|---------------------------------------------------------------------------------------|---------------------------------------------------------------------------------------------------------------------------------------------------------------------------------------------------------------------|
| <b>IMA</b>                                                                            | inverse multiplexing over ATM. A standard protocol defined by the ATM Forum in 1997.                                                                                                                                |
| <b>IMA control protocol cell</b>                                                      | See <i>ICP cell</i> .                                                                                                                                                                                               |
| <b>IMA group</b>                                                                      | Physical links grouped to form a higher-bandwidth logical link the rate of which is approximately the sum of the individual link rates.                                                                             |
| <b>industrial temperature</b>                                                         | See <i>ITEMP</i> .                                                                                                                                                                                                  |
| <b>Institute of Electrical and Electronics Engineers</b>                              | See <i>IEEE</i> .                                                                                                                                                                                                   |
| <b>Integrated Services Digital Network</b>                                            | See <i>ISDN</i> .                                                                                                                                                                                                   |
| <b>intermixing</b>                                                                    | Installation of line cards with different modulation types into a single DSLAM. Intermixing rules are determined by spectral frequency overlap considerations, chassis type, and line card modulation type.         |
| <b>International Organization for Standardization</b>                                 | See <i>ISO</i> .                                                                                                                                                                                                    |
| <b>International Telecommunication Union Telecommunication Standardization Sector</b> | See <i>ITU-T</i> .                                                                                                                                                                                                  |
| <b>inverse multiplexing</b>                                                           | Process whereby physical links are grouped to form a higher-bandwidth logical link whose rate is approximately the sum of the individual link rates.                                                                |
| <b>inverse mutliplexing over ATM</b>                                                  | See <i>IMA</i> .                                                                                                                                                                                                    |
| <b>ISDN</b>                                                                           | Integrated Services Digital Network. Communication protocol offered by telephone companies that permits telephone networks to carry data, voice, and other source traffic.                                          |
| <b>ISDN digital subscriber line</b>                                                   | See <i>IDSL</i> .                                                                                                                                                                                                   |
| <b>ISO</b>                                                                            | International Organization for Standardization. A voluntary, nontreaty organization founded in 1946 that is responsible for creating international standards in many areas, including computers and communications. |
| <b>ITEMP</b>                                                                          | industrial temperature.                                                                                                                                                                                             |
| <b>ITU-C</b>                                                                          | See <i>xTU-C</i> .                                                                                                                                                                                                  |

---

|              |                                                                                                                                                                                                                                                                                                           |
|--------------|-----------------------------------------------------------------------------------------------------------------------------------------------------------------------------------------------------------------------------------------------------------------------------------------------------------|
| <b>ITU-R</b> | See <i>xTU-R</i> .                                                                                                                                                                                                                                                                                        |
| <b>ITU-T</b> | International Telecommunication Union Telecommunication Standardization Sector. ITU-T is the telecommunication standardization sector of ITU and is responsible for making technical recommendations about telephone and data (including fax) communications systems for service providers and suppliers. |

---

|               |                                                                                                                                                                                               |
|---------------|-----------------------------------------------------------------------------------------------------------------------------------------------------------------------------------------------|
| <b>J</b>      |                                                                                                                                                                                               |
| <b>jitter</b> | In telecommunications, analog communication line distortion caused by the variation of a signal from its reference timing positions. Jitter can cause data loss, particularly at high speeds. |

---

|                             |                                                                                                                                                                                                                                                                                                                                                                                                                                                                 |
|-----------------------------|-----------------------------------------------------------------------------------------------------------------------------------------------------------------------------------------------------------------------------------------------------------------------------------------------------------------------------------------------------------------------------------------------------------------------------------------------------------------|
| <b>L</b>                    |                                                                                                                                                                                                                                                                                                                                                                                                                                                                 |
| <b>LAN</b>                  | local-area network. High-speed, low-error data network covering a relatively small geographic area (up to a few thousand meters). LANs connect workstations, peripherals, terminals, and other devices in a single building or other geographically limited area. LAN standards specify cabling and signaling at the physical and data link layers of the OSI model. Ethernet, FDDI, and Token Ring are widely used LAN technologies. Compare with <i>WAN</i> . |
| <b>laser</b>                | light amplification by stimulated emission of radiation. Analog transmission device in which a suitable active material is excited by an external stimulus to produce a narrow beam of coherent light that can be modulated into pulses to carry data. Networks based on laser technology are sometimes run over SONET.                                                                                                                                         |
| <b>LED</b>                  | light emitting diode. The lights indicate status or activity of electronic equipment.                                                                                                                                                                                                                                                                                                                                                                           |
| <b>light emitting diode</b> | See <i>LED</i> .                                                                                                                                                                                                                                                                                                                                                                                                                                                |
| <b>line rate</b>            | The speed at which data is transferred over a particular line type, expressed in bps.                                                                                                                                                                                                                                                                                                                                                                           |
| <b>link</b>                 | Network communications channel that consists of a circuit or transmission path and all related equipment between a sender and a receiver. In a transmission network, a link is a point-to-point connection between adjacent nodes.                                                                                                                                                                                                                              |
| <b>local-area network</b>   | See <i>LAN</i> .                                                                                                                                                                                                                                                                                                                                                                                                                                                |
| <b>logical port</b>         | A logical entry to a server machine. Logical ports are mostly invisible to the user, though you may occasionally see a URL with a port number included in it. These ports do not refer to physical locations; they are set up by server administrators for network trafficking.                                                                                                                                                                                 |
| <b>loopback</b>             | A diagnostic test that returns the transmitted signal to the sending device after the signal has passed through a network or across a particular link. The returned signal can then be compared to the transmitted one and the discrepancies between the two can be used to trace the fault. When you are trying to locate a faulty piece of equipment, you can repeat loopbacks, eliminating satisfactory machines, until the problem is found.                |

---

**M**

|                                    |                                                                                                                                                                                                                                            |
|------------------------------------|--------------------------------------------------------------------------------------------------------------------------------------------------------------------------------------------------------------------------------------------|
| <b>managed object</b>              | In network management, a network device that can be managed by a network management protocol.                                                                                                                                              |
| <b>Management Information Base</b> | See <i>MIB</i> .                                                                                                                                                                                                                           |
| <b>maximum rate</b>                | Maximum total data throughput allowed on a given virtual circuit. The maximum rate, which cannot exceed the media rate, represents the highest data throughput the virtual circuit will ever deliver, measured in bps or cells per second. |
| <b>MIB</b>                         | Management Information Base. A collection of objects that can be accessed through a network management protocol, such as SNMP or Common Management Information Protocol (CMIP).                                                            |
| <b>MMF</b>                         | multimode fiber. Optical fiber that supports the propagation of multiple frequencies of light. See also <i>SMF</i> .                                                                                                                       |
| <b>modulation</b>                  | Process by which the characteristics of electric signals are transformed to represent information. Types of modulation include AM, FM, and PAM. See also <i>AM</i> , <i>FM</i> , and <i>PAM</i> .                                          |
| <b>multicast</b>                   | Single packets copied by the network and sent to a specific subset of network addresses. Compare with <i>broadcast</i> and <i>unicast</i> .                                                                                                |
| <b>multimode fiber</b>             | See <i>MMF</i> .                                                                                                                                                                                                                           |
| <b>multiplexer</b>                 | Equipment that enables several data streams to be sent over a single physical line. A device for combining several channels to be carried by one line or fiber. See also <i>chassis</i> and <i>DSLAM</i> .                                 |

---

**N**

|                                           |                                                                                                                                                                                                                                                                       |
|-------------------------------------------|-----------------------------------------------------------------------------------------------------------------------------------------------------------------------------------------------------------------------------------------------------------------------|
| <b>NAT</b>                                | Network Address Translation. Mechanism for reducing the need for globally unique IP addresses. NAT allows an organization with addresses that are not globally unique to connect to the Internet by translating those addresses into globally routable address space. |
| <b>NEBS</b>                               | Network Equipment Building Systems. An extensive set of performance, quality, environmental and safety requirements developed by Bellcore (now Telcordia).                                                                                                            |
| <b>network</b>                            | Collection of computers, printers, routers, switches, and other devices that can communicate with each other over some transmission medium.                                                                                                                           |
| <b>Network Address Translation</b>        | See <i>NAT</i> .                                                                                                                                                                                                                                                      |
| <b>network element</b>                    | A network element is generally a combination hardware and software system that is designed primarily to perform a telecommunications service function.                                                                                                                |
| <b>Network Equipment Building Systems</b> | See <i>NEBS</i> .                                                                                                                                                                                                                                                     |
| <b>network management</b>                 | Generic term used to describe systems or actions that help maintain, characterize, or troubleshoot a network.                                                                                                                                                         |

|                                         |                                                                                                                                                                                                                                                                                                                                                                                                                                                                                                                                  |
|-----------------------------------------|----------------------------------------------------------------------------------------------------------------------------------------------------------------------------------------------------------------------------------------------------------------------------------------------------------------------------------------------------------------------------------------------------------------------------------------------------------------------------------------------------------------------------------|
| <b>network management system</b>        | See <i>NMS</i> .                                                                                                                                                                                                                                                                                                                                                                                                                                                                                                                 |
| <b>network timing reference</b>         | See <i>NTR</i> .                                                                                                                                                                                                                                                                                                                                                                                                                                                                                                                 |
| <b>NI-2 card</b>                        | A second generation network interface card for Cisco DSLAMs. Board that works with the network software and operating systems to transmit and receive messages on a network.                                                                                                                                                                                                                                                                                                                                                     |
| <b>NMS</b>                              | network management system. A system responsible for managing at least part of a network. An NMS communicates with agents to help keep track of network statistics and resources.                                                                                                                                                                                                                                                                                                                                                 |
| <b>node</b>                             | Endpoint of a network connection or a junction common to two or more lines in a network. Nodes can be processors, controllers, or workstations. Nodes can be interconnected by links and serve as control points in the network. Node sometimes is used generically to refer to any entity that can access a network, and frequently is used interchangeably with device. See also <i>host</i> .                                                                                                                                 |
| <b>node system save file</b>            | See <i>NSS file</i> .                                                                                                                                                                                                                                                                                                                                                                                                                                                                                                            |
| <b>noise margin</b>                     | Noise margin is the margin between the signal and noise in decibels (dB). The recommended minimum noise margin is typically 6dB. The 6dB noise margin was specified based on empirical research and the resulting algorithms to allow the best performance (line rate and reach) while maintaining the 10 <sup>-7</sup> bit-error rate. When RADSL is enabled for a DSL DMT application, the modem will train to 1) the specified rate or 2) the highest rate possible given the line conditions while maintaining a 6dB margin. |
| <b>nonvolatile random-access memory</b> | See <i>NVRAM</i> .                                                                                                                                                                                                                                                                                                                                                                                                                                                                                                               |
| <b>NSS file</b>                         | node system save file. The file that is saved during the Save Configuration procedure or during a software download. This file is required for the Restore Configurations procedure.                                                                                                                                                                                                                                                                                                                                             |
| <b>NTR</b>                              | Network timing reference. In DSL, NTR enables the DSLAM to provide clocking for network devices that reside beyond the CPE. The CPE must support NTR to enable this feature.                                                                                                                                                                                                                                                                                                                                                     |
| <b>NVRAM</b>                            | nonvolatile random-access memory. RAM that retains its contents when a unit is powered off.                                                                                                                                                                                                                                                                                                                                                                                                                                      |

---

## O

|                    |                                                                                                                                                                                                                                                                                                                                                                                                               |
|--------------------|---------------------------------------------------------------------------------------------------------------------------------------------------------------------------------------------------------------------------------------------------------------------------------------------------------------------------------------------------------------------------------------------------------------|
| <b>OAM&amp;P</b>   | operations, administration, management, and provisioning. Provides the facilities and the personnel required to manage a network.                                                                                                                                                                                                                                                                             |
| <b>OC</b>          | Optical Carrier. Series of physical protocols (OC-1, OC-2, OC-3, and so on) defined for SONET optical signal transmissions. OC signal levels put STS frames onto multimode fiber-optic line at a variety of speeds. The base rate is 51.84 Mbps (OC-1); each signal level thereafter operates at a speed divisible by that number (thus, OC-3 runs at 155.52 Mbps). See also <i>SONET</i> and <i>STS-3c</i> . |
| <b>OC-<i>n</i></b> | SONET optical carrier, Level <i>n</i> (such as <i>n</i> equals 3, 12, 48, 192).                                                                                                                                                                                                                                                                                                                               |

|                                                                 |                                                                                                                                                                                                                       |
|-----------------------------------------------------------------|-----------------------------------------------------------------------------------------------------------------------------------------------------------------------------------------------------------------------|
| <b>Open System Interconnection</b>                              | See <i>OSI</i> .                                                                                                                                                                                                      |
| <b>operations, administration, management, and provisioning</b> | See <i>OAM&amp;P</i> .                                                                                                                                                                                                |
| <b>Operations Support System</b>                                | See <i>OSS</i> .                                                                                                                                                                                                      |
| <b>octal-port DMT ATU-C line card</b>                           | See <i>8xDMT</i> .                                                                                                                                                                                                    |
| <b>octal-port ITU-C line card</b>                               | See <i>8xIDSL</i> .                                                                                                                                                                                                   |
| <b>octal-port SHTU-C line card</b>                              | See <i>8xG.SHDSL</i> .                                                                                                                                                                                                |
| <b>Optical Carrier</b>                                          | See <i>OC</i> .                                                                                                                                                                                                       |
| <b>optical fiber</b>                                            | See <i>MMF</i> and <i>SMF</i> .                                                                                                                                                                                       |
| <b>OSI</b>                                                      | Open System Interconnection. An international standardization program created by ISO and ITU-T to develop standards for data networking that facilitate multivendor equipment interoperability. See also <i>ISO</i> . |
| <b>OSS</b>                                                      | Operations Support System. Network management system supporting a specific management function, such as alarm surveillance and provisioning, in a carrier network.                                                    |

---

**P**

|                                     |                                                                                                                                                                                                                                                                                                                                                                                         |
|-------------------------------------|-----------------------------------------------------------------------------------------------------------------------------------------------------------------------------------------------------------------------------------------------------------------------------------------------------------------------------------------------------------------------------------------|
| <b>PAM</b>                          | pulse amplitude modulation. Modulation scheme where a continuous analog signal is represented with a series of discrete analog samples, which are then recreated as a complete signal. Sampling allows several signals to be combined on a channel that would otherwise carry only one signal. Compare with <i>AM</i> and <i>FM</i> . See also <i>modulation</i> .                      |
| <b>parent</b>                       | See <i>subtending host chassis</i> .                                                                                                                                                                                                                                                                                                                                                    |
| <b>PEM</b>                          | power entry module. A hardware module that distributes power throughout a DSLAM.                                                                                                                                                                                                                                                                                                        |
| <b>performance management</b>       | One of five categories of network management defined by ISO for the management of ISO networks. Performance management subsystems are responsible for analyzing and controlling network performance, including network throughput and error rates. See also <i>accounting management</i> , <i>configuration management</i> , <i>fault management</i> , and <i>security management</i> . |
| <b>permanent virtual circuit</b>    | See <i>PVC</i> .                                                                                                                                                                                                                                                                                                                                                                        |
| <b>permanent virtual connection</b> | See <i>PVC</i> .                                                                                                                                                                                                                                                                                                                                                                        |

|                                    |                                                                                                                                                                                                                                                                                                         |
|------------------------------------|---------------------------------------------------------------------------------------------------------------------------------------------------------------------------------------------------------------------------------------------------------------------------------------------------------|
| <b>permanent virtual path</b>      | See <i>PVP</i> .                                                                                                                                                                                                                                                                                        |
| <b>physical port</b>               | A physical connection to a computer through which data flows. An Ethernet port, for example, is the point at which the Ethernet network cabling plugs into a computer.                                                                                                                                  |
| <b>plain old telephone service</b> | See <i>POTS</i> .                                                                                                                                                                                                                                                                                       |
| <b>Point-to-Point Protocol</b>     | See <i>PPP</i> .                                                                                                                                                                                                                                                                                        |
| <b>port</b>                        | An interface on an internetworking device (such as a DSLAM).                                                                                                                                                                                                                                            |
| <b>POTS</b>                        | plain old telephone service. General term referring to the variety of telephone networks and services in place worldwide.                                                                                                                                                                               |
| <b>POTS splitter</b>               | A device that enables both a DSL data device and a standard analog device to share the same ADSL or IDSL line.                                                                                                                                                                                          |
| <b>power entry module</b>          | See <i>PEM</i> .                                                                                                                                                                                                                                                                                        |
| <b>PPP</b>                         | Point-to-Point Protocol. The successor to SLIP that provides router-to-router and host-to-network connections over both synchronous and asynchronous circuits. See <i>SLIP</i> .                                                                                                                        |
| <b>protocol</b>                    | A formal description of messages to be exchanged and rules to be followed so that two or more systems can exchange information.                                                                                                                                                                         |
| <b>pulse amplitude modulation</b>  | See <i>PAM</i> .                                                                                                                                                                                                                                                                                        |
| <b>PVC</b>                         | permanent virtual circuit (or connection). A virtual circuit that is permanently established. PVCs save bandwidth associated with circuit establishment and tear down in situations where certain virtual circuits must exist all the time. Compare with <i>SVC</i> . See also <i>virtual circuit</i> . |
| <b>PVP</b>                         | permanent virtual path. A virtual path that consists of PVCs. See also <i>PVC</i> and <i>virtual path</i> .                                                                                                                                                                                             |

---

## Q

|                                        |                                                                                                                                         |
|----------------------------------------|-----------------------------------------------------------------------------------------------------------------------------------------|
| <b>QoS</b>                             | quality of service. A measure of performance for a transmission system that reflects its transmission quality and service availability. |
| <b>quad-port flexi ATU-C line card</b> | See <i>4xflexi</i> .                                                                                                                    |
| <b>quad-port STU-C line card</b>       | See <i>4xSDSL</i> .                                                                                                                     |
| <b>quality of service</b>              | See <i>QoS</i> .                                                                                                                        |

---

**R**

|                                                   |                                                                                                                                                                                                                                                                                                                                                                                                                                              |
|---------------------------------------------------|----------------------------------------------------------------------------------------------------------------------------------------------------------------------------------------------------------------------------------------------------------------------------------------------------------------------------------------------------------------------------------------------------------------------------------------------|
| <b>RADIUS</b>                                     | Remote Authentication Dial-In User Service. A client/server security protocol created by Livingston Enterprises. Security information is stored in a central location, known as the RADIUS server.                                                                                                                                                                                                                                           |
| <b>RADSL</b>                                      | rate adaptive digital subscriber line. A transmission technology that supports adaptive transmission rates through the use of intelligent DSL modems, which negotiate the line rate according to line conditions and profile specifications. Once the line rate is negotiated, the rate is locked when the line trains. RADSL supports both asymmetric and symmetric applications on a single twisted pair telephone line. See <i>ADSL</i> . |
| <b>RAM</b>                                        | random-access memory. Volatile memory that can be read and written by a microprocessor.                                                                                                                                                                                                                                                                                                                                                      |
| <b>random-access memory</b>                       | See <i>RAM</i> .                                                                                                                                                                                                                                                                                                                                                                                                                             |
| <b>Rate Adaptive Digital Subscriber Line</b>      | See <i>RADSL</i> .                                                                                                                                                                                                                                                                                                                                                                                                                           |
| <b>read-only memory</b>                           | See <i>ROM</i> .                                                                                                                                                                                                                                                                                                                                                                                                                             |
| <b>redundancy</b>                                 | In internetworking, the duplication of devices, services, or connections so that, in the event of failure, the redundant devices, services, or connections can perform the work of those that failed.                                                                                                                                                                                                                                        |
| <b>remote address</b>                             | The IP address of a remote server.                                                                                                                                                                                                                                                                                                                                                                                                           |
| <b>Remote Authentication Dial-In User Service</b> | See <i>RADIUS</i> .                                                                                                                                                                                                                                                                                                                                                                                                                          |
| <b>remote monitoring</b>                          | See <i>RMON</i> .                                                                                                                                                                                                                                                                                                                                                                                                                            |
| <b>remote server</b>                              | A network computer that allows a user to log on to the network from a distant location.                                                                                                                                                                                                                                                                                                                                                      |
| <b>Request for Comments</b>                       | See <i>RFC</i> .                                                                                                                                                                                                                                                                                                                                                                                                                             |
| <b>RFC</b>                                        | Request for Comments. The document series, begun in 1969, which describes the Internet suite of protocols and related experiments. Not all RFCs describe Internet standards, but all Internet standards are written up as RFCs.                                                                                                                                                                                                              |
| <b>ring topology</b>                              | A method of connecting devices so that a series of repeaters is connected to one another by unidirectional transmission links to form a single closed loop. Each station on the network connects to the network at a repeater. Compare with <i>bus topology</i> , <i>daisy-chain topology</i> , <i>star topology</i> , and <i>tree topology</i> .                                                                                            |
| <b>RMON</b>                                       | remote monitoring. MIB agent specification described in RFC 1271 that defines functions for the remote monitoring of networked devices. The RMON specification provides numerous monitoring, problem detection, and reporting capabilities.                                                                                                                                                                                                  |
| <b>ROM</b>                                        | read-only memory. Nonvolatile memory that can be read, but not written, by the microprocessor.                                                                                                                                                                                                                                                                                                                                               |

|                      |                                                                                                                                                                                                                                                                                                                                     |
|----------------------|-------------------------------------------------------------------------------------------------------------------------------------------------------------------------------------------------------------------------------------------------------------------------------------------------------------------------------------|
| <b>router</b>        | A system responsible for making decisions about which of several paths network (or Internet) traffic will follow. The router uses a routing protocol to gain information about the network and algorithms to choose the best route based on several criteria known as “routing metrics.” See also <i>bridge</i> and <i>switch</i> . |
| <b>routing table</b> | A table that is stored in a router or some other internetworking device that keeps tracks of routes to particular network destinations, and, in some cases, metrics associated with those routes. A routing table is used to select the most appropriate route to forward information.                                              |

---

**S**

|                                                       |                                                                                                                                                                                                                                                                                                                                                                                                                                                                |
|-------------------------------------------------------|----------------------------------------------------------------------------------------------------------------------------------------------------------------------------------------------------------------------------------------------------------------------------------------------------------------------------------------------------------------------------------------------------------------------------------------------------------------|
| <b>scalability</b>                                    | Capacity of a network to keep pace with changes and growth.                                                                                                                                                                                                                                                                                                                                                                                                    |
| <b>SDSL</b>                                           | symmetrical digital subscriber line. An xDSL technology that can deliver 1.168 Mbps downstream and upstream over a single copper twisted pair. The use of a single twisted pair limits the operating range of SDSL to 10,000 feet (3048.8 meters). Compare with <i>ADSL</i> , <i>IDSL</i> , and <i>SHDSL</i> . See also <i>DSL</i> .                                                                                                                           |
| <b>security management</b>                            | One of five categories of network management defined by ISO for the management of ISO networks. Security management subsystems are responsible for controlling access to network resources. See also <i>accounting management</i> , <i>configuration management</i> , <i>fault management</i> , and <i>performance management</i> .                                                                                                                            |
| <b>Serial Line Internet Protocol</b>                  | See <i>SLIP</i> .                                                                                                                                                                                                                                                                                                                                                                                                                                              |
| <b>server</b>                                         | Node or software program that provides services to clients.                                                                                                                                                                                                                                                                                                                                                                                                    |
| <b>SHDSL</b>                                          | single-pair high-speed digital subscriber line, also known as symmetric high bit rate digital subscriber loop. A version of xDSL that includes advanced Trellis line code, a precoding mechanism, spectral shaping, equalization circuits, and forward error correction. SHDSL can deliver 2.312 Mbps of bandwidth downstream and upstream over a single copper twisted pair. Compare with <i>ADSL</i> , <i>IDSL</i> , and <i>SDSL</i> . See also <i>DSL</i> . |
| <b>shielded twisted pair</b>                          | A pair of insulated wires which are twisted together in a spiral manner. In addition, the pair is wrapped with metallic foil or braid, designed to insulate the pair from electromagnetic interference. Sometimes referred to as STP. See also <i>twisted pair</i> and <i>unshielded twisted pair</i> .                                                                                                                                                        |
| <b>SHTU-C</b>                                         | See <i>xTU-C</i> .                                                                                                                                                                                                                                                                                                                                                                                                                                             |
| <b>SHTU-R</b>                                         | See <i>xTU-R</i> .                                                                                                                                                                                                                                                                                                                                                                                                                                             |
| <b>signal-to-noise ratio</b>                          | See <i>SNR</i> .                                                                                                                                                                                                                                                                                                                                                                                                                                               |
| <b>Simple Network Management Protocol</b>             | See <i>SNMP</i> .                                                                                                                                                                                                                                                                                                                                                                                                                                              |
| <b>single-mode fiber</b>                              | See <i>SMF</i> .                                                                                                                                                                                                                                                                                                                                                                                                                                               |
| <b>single-pair high-speed digital subscriber line</b> | See <i>SHDSL</i> .                                                                                                                                                                                                                                                                                                                                                                                                                                             |



|                                |                                                                                                                                                                                                                                                                             |
|--------------------------------|-----------------------------------------------------------------------------------------------------------------------------------------------------------------------------------------------------------------------------------------------------------------------------|
| <b>SLIP</b>                    | Serial Line Internet Protocol. A standard protocols for point-to-point serial connections using a variation of TCP/IP. This protocol is the predecessor of PPP. See <i>PPP</i> and <i>TCP</i> .                                                                             |
| <b>slot</b>                    | A numbered location within a chassis, which is capable of housing a card or module.                                                                                                                                                                                         |
| <b>SMF</b>                     | single-mode fiber. Fiber-optic cabling with a narrow core that allows light to enter only at a single angle. Such cabling has higher bandwidth than multimode fiber, but requires a light source with a narrow spectral width (for example, a laser). See also <i>MMF</i> . |
| <b>SNMP</b>                    | Simple Network Management Protocol. The network management protocol of choice for TCP/IP-based internets. SNMP provides a means to monitor and control network devices, and to manage configurations, statistics collection, performance, and security.                     |
| <b>SNR</b>                     | signal-to-noise ratio. The usable signal being transmitted divided by the noise or undesired signal. SNR is a measure of transmission quality.                                                                                                                              |
| <b>SONET</b>                   | Synchronous Optical Network. A standard format for transporting a wide range of digital communications services over optical fiber. SONET is characterized by standard line rates, optical interfaces, and signal formats.                                                  |
| <b>source address</b>          | Address of a network device that sends data. See also <i>destination address</i> .                                                                                                                                                                                          |
| <b>star topology</b>           | A method of connecting devices in which end points on a network are connected to a common central switch by point-to-point links. Compare with <i>bus topology</i> , <i>daisy-chain topology</i> , <i>ring topology</i> , and <i>tree topology</i> .                        |
| <b>STM-1</b>                   | Synchronous Transfer Module 1. Synchronous Digital Hierarchy standard for transmission over OC-3c optical fiber at 155.52 Mbps.                                                                                                                                             |
| <b>STS-3c</b>                  | Synchronous Transport Signal level 3, concatenated. SONET format that specifies the frame structure for the 155.52 Mbps-lines used to carry ATM cells. See also <i>SONET</i> .                                                                                              |
| <b>STU-C</b>                   | See <i>xTU-C</i> .                                                                                                                                                                                                                                                          |
| <b>STU-R</b>                   | See <i>xTU-R</i> .                                                                                                                                                                                                                                                          |
| <b>subinterface</b>            | One of a number of virtual interfaces on a single physical interface.                                                                                                                                                                                                       |
| <b>subnet</b>                  | For routing purposes, IP networks can be divided into logical subnets by means of a subnet mask. Values below those of the mask are valid addresses on the subnet.                                                                                                          |
| <b>subnet address</b>          | Portion of an IP address that is specified as the subnetwork by the subnet mask.                                                                                                                                                                                            |
| <b>subnet mask</b>             | The 32-bit address mask used in IP to indicate the bits of an IP address that are being used for the subnet address.                                                                                                                                                        |
| <b>subrack discovery</b>       | The process by which a DSLAM node automatically searches through the interfaces and ports within that DSLAM and discovers the components that are present within that DSLAM.                                                                                                |
| <b>subscriber</b>              | A logical entity with attributes identifying the customer that is receiving service on a particular port.                                                                                                                                                                   |
| <b>subtended configuration</b> | Services and aggregates the data from one or more chassis into a subtending host chassis requiring only one connection to the outside network. This reduces the number of ATM edge-switch ports necessary to terminate multiple chassis.                                    |

|                                                           |                                                                                                                                                                                                                                                                                    |
|-----------------------------------------------------------|------------------------------------------------------------------------------------------------------------------------------------------------------------------------------------------------------------------------------------------------------------------------------------|
| <b>subtended node chassis</b>                             | Downstream chassis in a subtended network configuration. Also known as the <i>child</i> .                                                                                                                                                                                          |
| <b>subtending</b>                                         | See <i>subtended configuration</i> .                                                                                                                                                                                                                                               |
| <b>subtending host chassis</b>                            | Provides the data network interface for the subtended node chassis and connects to the ATM backbone. Also known as the <i>parent</i> .                                                                                                                                             |
| <b>SVC</b>                                                | switched virtual circuit (or connection). A virtual circuit that is dynamically established on demand and is torn down when transmission is complete. SVCs are used in situations where data transmission is sporadic. Compare with <i>PVC</i> . See also <i>virtual circuit</i> . |
| <b>switch</b>                                             | Network device that filters, forwards, and floods frames based on the destination address of each frame. The switch operates at the data link layer of the OSI model. See also <i>bridge</i> and <i>router</i> .                                                                   |
| <b>switched virtual circuit</b>                           | See <i>SVC</i> .                                                                                                                                                                                                                                                                   |
| <b>symmetric high bit rate digital subscriber loop</b>    | See <i>SHDSL</i> .                                                                                                                                                                                                                                                                 |
| <b>symmetrical digital subscriber line</b>                | See <i>SDSL</i> .                                                                                                                                                                                                                                                                  |
| <b>synchronous communications</b>                         | Data is not sent in individual bytes, but as frames of large data blocks.                                                                                                                                                                                                          |
| <b>Synchronous Optical Network</b>                        | See <i>SONET</i> .                                                                                                                                                                                                                                                                 |
| <b>Synchronous Transfer Module 1</b>                      | See <i>STM-1</i> .                                                                                                                                                                                                                                                                 |
| <b>Synchronous Transport Signal level 3, concatenated</b> | See <i>STS-3c</i> .                                                                                                                                                                                                                                                                |
| <b>SYSLOG</b>                                             | SYSLOG allows you to log significant system information to a remote server.                                                                                                                                                                                                        |

---

## T

|               |                                                                                                                                                                              |
|---------------|------------------------------------------------------------------------------------------------------------------------------------------------------------------------------|
| <b>T1</b>     | A digital carrier that is used to transmit a DS1 formatted digital signal at 1.544 Mbps through the telephone-switching network. See also <i>E1</i> .                        |
| <b>T1.413</b> | The ANSI standard for line coding and framing for full rate ADSL.                                                                                                            |
| <b>T3</b>     | A digital carrier that is used to transmit a DS3 formatted digital signal at 45 Mbps through the telephone-switching network. Compare with <i>E3</i> . See also <i>DS3</i> . |

|                                                 |                                                                                                                                                                                                                                                                                                                                                                  |
|-------------------------------------------------|------------------------------------------------------------------------------------------------------------------------------------------------------------------------------------------------------------------------------------------------------------------------------------------------------------------------------------------------------------------|
| <b>TC-PAM</b>                                   | trellis coded pulse amplitude modulation. Trellis coding provides forward error correction, while pulse amplitude modulation is a modulation scheme where a continuous analog signal is represented with a series of discrete analog samples.                                                                                                                    |
| <b>TCP</b>                                      | Transmission Control Protocol. The major transport protocol in the Internet suite of protocols providing reliable, connection-oriented, full-duplex streams. See <i>SLIP</i> .                                                                                                                                                                                   |
| <b>Telnet</b>                                   | The virtual terminal protocol in the Internet suite of protocols. It allows users of one host to log in to a remote host and use resources as if they were connected to a local system.                                                                                                                                                                          |
| <b>TFTP</b>                                     | Trivial File Transfer Protocol. A simple file transfer protocol (a simplified version of FTP) that allows files to be transferred from one computer to another over a network. TFTP does not offer password security.                                                                                                                                            |
| <b>tip and ring</b>                             | A pair of wires that provide the electrical connection between a telephone set and the local CO. The more electrically positive side of a POTS telephone line (0 V) is the tip. Its counterpart is the ring, which is the more negative side, 52 v).                                                                                                             |
| <b>topology</b>                                 | Physical arrangement of network nodes and media within a networking structure.                                                                                                                                                                                                                                                                                   |
| <b>trailer</b>                                  | A block of information that is transmitted at the end of a message to trace error impacts and missing blocks.                                                                                                                                                                                                                                                    |
| <b>training</b>                                 | The handshake procedure that initiates and establishes an end-to-end xDSL connection                                                                                                                                                                                                                                                                             |
| <b>training mode</b>                            | The mode, either standard or quick, that a DSLAM port employs when it is training to a CPE. The training mode uses RADSL technology to adjust line speed according to noise conditions on the transmission line.                                                                                                                                                 |
| <b>Transmission Control Protocol</b>            | See <i>TCP</i> .                                                                                                                                                                                                                                                                                                                                                 |
| <b>trap</b>                                     | Message sent by SNMP agent to an NMS, a console, or a terminal to indicate the occurrence of a significant event, such as a specifically defined condition or a threshold that was reached. See also <i>alarm</i> and <i>event</i> .                                                                                                                             |
| <b>tree topology</b>                            | A method of connecting devices that is similar to a bus topology, except that tree networks can contain branches with multiple nodes. Transmissions from a station propagate the length of the medium and are received by all other stations. Compare with <i>bus topology</i> , <i>daisy-chain topology</i> , <i>ring topology</i> , and <i>star topology</i> . |
| <b>trellis coded pulse amplitude modulation</b> | See <i>TC-PAM</i> .                                                                                                                                                                                                                                                                                                                                              |
| <b>trellis encoding</b>                         | A channel coding technique which provides forward error correction capability.                                                                                                                                                                                                                                                                                   |
| <b>Trivial File Transfer Protocol</b>           | See <i>TFTP</i> .                                                                                                                                                                                                                                                                                                                                                |
| <b>twisted pair</b>                             | Two insulated copper wires twisted together with the twists or lays varied in length to reduce potential signal interference between the pairs.                                                                                                                                                                                                                  |

---

**U**

- UBR** unspecified bit rate. A QoS class defined by the ATM Forum for ATM networks. UBR allows any amount of data up to a specified maximum to be sent across the network but there are no guarantees in terms of cell loss rate and delay. Compare with *ABR*, *CBR*, and *VBR*.
- UDP** User Datagram Protocol. A connectionless transport protocol that runs on top of the TCP/IP. UDP, like TCP, uses IP for delivery; however, unlike TCP, UDP provides for exchange of datagrams without acknowledgments or guaranteed delivery. This protocol is the best suited for small, independent requests, such as requesting a MIB value from an SNMP agent, in which setting up a connection would take more time than sending the data.
- UL** Underwriters Laboratories. A private organization that tests and certifies electrical components and devices against rigorous safety standards. A UL Listing Mark on a product means that representative samples of the product have been tested and evaluated against nationally recognized safety standards with regard to fire, electric shock, and other related safety hazards, and have met the standards.
- Underwriters Laboratories** See *UL*.
- UNI** User-Network Interface.
- UNI signaling** User-Network Interface signaling for ATM communications.
- unicast** Message sent to a single network destination. Compare with *broadcast* and *multicast*.
- unshielded twisted pair** Four-pair wire medium used in a variety of networks. Sometimes referred to as UTP. See also *shielded twisted pair* and *twisted pair*.
- unspecified bit rate** See *UBR*.
- upstream** Data that is coming from the subscriber lines to the NI-2 card. See also downstream.
- User-Network Interface** See *UNI*.
- User Datagram Protocol** See *UDP*.

---

**V**

- variable bit rate** See *VBR*.
- VBR** variable bit rate. A QoS defined by the ATM Forum for ATM networks. VBR is subdivided into a real time (rt) class and non-real time (nrt) class. VBR-rt is used for connections in which there is a fixed timing relationship between samples. VBR-nrt is used for connections in which there is no fixed timing relationship between samples but that still need a guaranteed QoS. Compare with *ABR*, *CBR*, and *UBR*.
- VCC** virtual channel connection. A logical circuit, made up of links, that carries data between two endpoints in an ATM network. It is sometimes called a virtual circuit connection. See also *VCI* and *VPI*.

|                                   |                                                                                                                                                                                                                                                                              |
|-----------------------------------|------------------------------------------------------------------------------------------------------------------------------------------------------------------------------------------------------------------------------------------------------------------------------|
| <b>VCI</b>                        | virtual channel identifier. A 16-bit field in the header of an ATM cell. The VCI, together with the VPI, is used to identify the next destination of a cell as it passes through to the ATM switch. It is sometimes called virtual circuit identifier. See also <i>VPI</i> . |
| <b>virtual channel connection</b> | See <i>VCC</i> .                                                                                                                                                                                                                                                             |
| <b>virtual channel identifier</b> | See <i>VCI</i> .                                                                                                                                                                                                                                                             |
| <b>virtual circuit</b>            | A logical circuit created to ensure reliable communication between two network devices. A virtual circuit is defined by a VPI/VCI pair and can be either PVC or SVC. In ATM, a virtual circuit is called a virtual channel. See also PVC, SVC, VCI, and VPI.                 |
| <b>virtual circuit connection</b> | See <i>VCC</i> .                                                                                                                                                                                                                                                             |
| <b>virtual circuit identifier</b> | See <i>VCI</i> .                                                                                                                                                                                                                                                             |
| <b>virtual connection</b>         | In ATM, a connection between end users that has a defined route and endpoints. See also <i>PVC</i> and <i>SVC</i> .                                                                                                                                                          |
| <b>virtual path</b>               | A logical grouping of virtual circuits that connect two sites. One of two types of ATM circuits identified by a VPI. A virtual path is a bundle of virtual circuits, all of which are switched across a network based on a common VPI. See also <i>VPI</i> .                 |
| <b>virtual path identifier</b>    | See <i>VPI</i> .                                                                                                                                                                                                                                                             |
| <b>VPI</b>                        | virtual path identifier. An 8-bit field in the header of an ATM cell. The VPI, together with the VCI, is used to identify the next destination of a cell as it passes through the network. See also <i>VCI</i> .                                                             |

---

## W

|                           |                                                                                                                                                                                                                                                  |
|---------------------------|--------------------------------------------------------------------------------------------------------------------------------------------------------------------------------------------------------------------------------------------------|
| <b>WAN</b>                | wide-area network. A data communications network that serves users across a broad geographic area and often uses transmission devices provided by common carriers. Compare with <i>LAN</i> .                                                     |
| <b>WAN Interface Card</b> | See <i>WIC</i> .                                                                                                                                                                                                                                 |
| <b>WIC</b>                | WAN Interface Card. A WIC card plugs into the card slot of a router and allows DSL use on routers. Each WIC acts as a CPE and can handle the amount of data available depending on the line conditions and the DSL profile assigned to the port. |
| <b>wide-area network</b>  | See <i>WAN</i> .                                                                                                                                                                                                                                 |

---

**X**

- xDSL** Generic term used to refer to digital subscriber line equipment and services, including ADSL, IDSL, SDSL, and SHDSL. All are digital technologies that provide high bandwidth over existing copper infrastructure provided by the telephone companies.
- xDSL Transmission Unit—central office** See xTU-C.
- xDSL Transmission Unit—remote** See xTU-R.
- xTU-C** xDSL Transmission Unit—central office. A hardware device that supports xDSL communication and that is placed in the CO. The xTU-C has a matching unit on the subscriber premise in the form of an xTU-R. The two units, in combination, support a high data rate over UTP copper cable local loops. Examples of xTU-Cs are ATU-C, ITU-C, STU-C, and SHTU-C.
- xTU-R** xDSL Transmission Unit—remote. A hardware device that supports xDSL communication and that is placed in the customer's premise. The xTU-R has a matching unit in the carrier's CO in the form of an xTU-C. The two units, in combination, support a high data rate over UTP copper cable local loops. Examples of xTU-Rs are ATU-R, ITU-R, STU-R, and SHTU-R.



---

## Numerics

### 4xDMT

- faceplate **1-14**
- features **1-13**
- installing **6-7**
- LEDs **1-14**
- specifications **A-3**
- troubleshooting **5-10**

### 4xDMT over ISDN

- faceplate **1-16**
- features **1-15**
- installing **6-7**
- LEDs **1-16**
- specifications **A-4**
- troubleshooting **5-10**

### 4xflexi

- faceplate **1-18**
- features **1-17**
- installing **6-7**
- LEDs **1-18**
- specifications **A-4**
- troubleshooting **5-10**

### 4xSDSL

- faceplate **1-20**
- features **1-19**
- installing **6-7**
- LEDs **1-20**
- specifications **A-5**
- troubleshooting **5-10**

### 8xDMT

- faceplate **1-22**
- features **1-21**

installing **6-7**

LEDs **1-22**

specifications **A-6**

troubleshooting **5-10**

### 8xDMT over ISDN

faceplate **1-24**

features **1-23**

installing **6-7**

LEDs **1-24**

specifications **A-7**

troubleshooting **5-10**

### 8xG.SHDSL

faceplate **1-26**

features **1-25**

installing **6-7**

intermixing **1-28**

12.1(7)DA2 **1-28**

12.2(1b)DA **1-28**

12.2(5)DA **1-28**

LEDs **1-26**

specifications **A-7**

troubleshooting **5-10**

---

## A

### air filter

cleaning **6-4**

removing **6-3**

replacing **6-4**

required tools and equipment **6-2**

### alarms

BITS clock **5-17**

card slots **5-17**

chassis alarms **5-17**  
 connecting **3-13, 4-12**  
 E1 interface **5-19**  
 E3 interfaces **5-18**  
 fan tray **5-21**  
 IMA  
   group **5-20**  
   link network interface **5-19**  
 IOS Controller **5-17**  
 line cards **5-17**  
 management software **1-49**  
 OC-3c interfaces **5-18**  
 PEM **5-21**  
 redundancy **5-20**  
 T1 network interface **5-19**  
 troubleshooting **5-17**  
 altitude requirements **2-12**  
 attaching power connections **3-9, 4-9**  
 auxiliary port  
   connecting **3-21, 4-20**  
   pin assignments **C-4**

---

## B

blank faceplates, installation **3-6, 4-6**

---

## C

cabling guidelines **B-1**  
 caution definition **xv**  
 Cisco 6260  
   card slot assignments **1-11**  
   card slots **1-12**  
   champ connectors **1-13**  
   features **1-3**  
 Cisco 6260 chassis  
   installation with a POTS splitter **3-5**  
   installation without a POTS splitter **4-5**

Cisco IOS definition **1-49**  
 console port pin assignments **C-4**  
 contacting Cisco TAC, see troubleshooting

---

## D

documentation  
   related **xv**  
 DS3+T1/E1 IMA NI-2 card  
   faceplate **1-33**  
   features **1-32**  
   installing **6-13**  
   redundancy **1-39**  
   removing **6-14**  
   specifications **A-9**  
   subtending **1-9**  
   troubleshooting **5-8**  
 DS3/2DS3 NI-2 card  
   faceplate **1-31**  
   features **1-30**  
   installing **6-10**  
   redundancy **1-39**  
   removing **6-12**  
   specifications **A-8**  
   subtending **1-7**  
   troubleshooting **5-8**  
 DSL connector pin locations **C-1**

---

## E

E1 I/O module  
   connecting the E1 subtending network  
     configuration **3-19, 4-18**  
   network connection installation **3-16, 4-15**  
   network interface alarms **5-19**  
   troubleshooting **5-14**  
 E3 I/O module  
   features **1-41**  
   network connection installation **3-15, 4-14**



- troubleshooting **5-14**
- electrostatic discharge, preventing **2-9**
- environmental requirements
  - space **2-13**
  - temperature, altitude, and humidity **2-12**
  - ventilation **2-12**
- ESD jack location **1-48**
- Ethernet
  - connect to management network **3-20, 4-19**
  - pin assignments **C-5**

---

## F

- fan tray
  - features **1-47**
  - illustration **1-47**
  - maintenance **6-2**
  - removing and replacing **6-4**
  - specifications **A-12**
  - troubleshooting **5-15**

---

## G

- general maintenance guidelines
  - hot swapping cards **2-10**
  - hot swapping modules **2-10**
  - installation and replacement suggestions **2-11**
- guide contents, description **xiii**

---

## H

- hardware specifications, see specifications
- hot swapping
  - cards **2-10**
  - modules **2-10**
  - troubleshooting **5-1**
- humidity requirements **2-12**

---

## I/O module

- connectors **C-1**
- installing **6-18**
- removing **6-19**
- specifications **A-11**
- troubleshooting **5-14**
- wire-wrap pin mapping **C-3**
- wire-wrap pins **1-44, C-3**
- wire-wrap pins illustration **1-44**

## IMA

- configuration **1-4**
- definition **1-4**
- group alarms **5-20**
- link network interface alarms **5-19**
- initial configuration **3-22, 4-21**
- inspecting for damage **2-18**
- installation and replacement suggestions
  - general maintenance guidelines **2-11**
- installation checklist
  - with a POTS splitter **3-2**
  - without a POTS splitter **4-2**
- installation procedures
  - with a POTS splitter **3-3**
  - without a POTS splitter **4-2**
- installation tools and equipment **2-16**
- installation with a POTS splitter
  - apply power **3-14**
  - attach ear brackets **3-4**
  - attach power connections **3-9**
  - blank faceplates **3-6**
  - checklist **3-2**
  - Cisco 6260 chassis **3-5**
  - connect a console terminal **3-21**
  - connecting the E1 subtending network
    - configuration **3-19**
  - connecting the OC-3c subtending network
    - configuration **3-20**

- connect the alarm contacts **3-13**
- connect the auxiliary port **3-21**
- connect the Cisco 6260 to the third-party POTS splitter **3-9**
- connect the Ethernet to the management network **3-20**
- E1 network connection installation **3-16**
- E3 network connection **3-15**
- ground the Cisco 6260 and the third-party POTS splitter **3-7**
- initial configuration **3-22**
- installing a subtended network configuration **3-18**
- OC-3c network connection installation **3-17**
- procedures **3-3**
- stabilize and measure rack space **3-3**
- verify fan tray operation **3-15**
- installation without a POTS splitter
  - apply power **4-13**
  - attach ear brackets **4-4**
  - attach power connections **4-9**
  - blank faceplates **4-6**
  - checklist **4-2**
  - Cisco 6260 chassis **4-5**
  - connect a console terminal **4-20**
  - connecting the E1 subtending network configuration **4-18**
  - connecting the OC-3c subtending network configuration **4-19**
  - connect the alarm contacts **4-12**
  - connect the auxiliary port **4-20**
  - connect the Cisco 6260 to the MDF **4-8**
  - connect the Ethernet to the management network **4-19**
  - E1 network connection installation **4-15**
  - E3 network connection **4-14**
  - ground the Cisco 6260 **4-7**
  - initial configuration **4-21**
  - installing a subtended network configuration **4-17**
  - OC-3c network connection installation **4-16**
  - procedures **4-2**
  - stabilize and measure rack space **4-2**
  - verify fan tray operation **4-14**

- intermixing
  - G.SHDSL guidelines
    - Release 12.1(7)DA2 **1-28**
    - Release 12.2(1b)DA **1-28**
    - Release 12.2(5)DA **1-28**
- intermixing line cards **1-27**
- IOS controller alarms **5-17**

---

## L

- LEDs
  - 4xDMT **1-14**
  - 4xDMT over ISDN **1-16**
  - 4xflexi **1-18**
  - 4xSDSL **1-20**
  - 8xDMT **1-22**
  - 8xDMT over ISDN **1-24**
  - 8xG.SHDSL **1-26**
  - PEM **1-46**
- line cards
  - 4xDMT **1-13**
  - 4xDMT over ISDN **1-15**
  - 4xflexi **1-17**
  - 4xSDSL **1-19**
  - 8xDMT **1-21**
  - 8xDMT over ISDN **1-23**
  - 8xG.SHDSL **1-25**
  - intermixing **1-27, 1-28**
  - troubleshooting **5-10**

---

## M

- management software
  - alarms **1-49**
  - Cisco IOS **1-49**
  - specifications **A-12**

---

**N**

- network clocking **1-39**
- NI-2 cards
  - DS3+T1/E1 IMA NI-2 card **1-32**
  - DS3/2DS3 NI-2 card **1-30**
  - OC-3c/OC-3c NI-2 card **1-35**
  - troubleshooting **5-8**
- note, definition **xv**

---

**O**

- OC-3c/OC-3c NI-2 card
  - faceplate **1-37**
  - features **1-35**
  - installing **6-16**
  - redundancy **1-39**
  - removing **6-17**
  - specifications **A-10**
  - subtending **1-10**
  - troubleshooting **5-8**
- OC-3c I/O module
  - connecting the OC-3c subtending network configuration **3-20, 4-19**
  - illustration **1-43**
  - network connection installation **3-17, 4-16**
  - troubleshooting **5-14**

---

**P**

- PEM
  - alarms **5-21**
  - faceplate **1-46**
  - features **1-45**
  - installing **6-20**
  - LEDs **1-46**
  - removing **6-22**
  - specifications **A-11**
  - troubleshooting **5-16**

- pin assignments
  - auxiliary ports **C-4**
  - console port **C-4**
  - Ethernet port **C-5**
- port mapping table **B-2**
- POTS splitter
  - connect the third-party POTS splitter to the Cisco 6260 **3-9**
- power requirements **2-14**
- preventing electrostatic discharge **2-9**

---

**Q**

- quadrants
  - intermixing **1-28**

---

**R**

- rack-mounting **2-15**
- rack space calculation **2-14**
- redundancy
  - alarms **5-20**
  - APS link **1-40**
  - NI-2 cards **1-39**
  - overview **1-39**
  - subtended configurations **1-41**
  - troubleshooting **5-9**
- required tools and equipment **2-16**

---

**S**

- safety requirements
  - preventing electrostatic discharge **2-9**
  - safety guidelines **2-1**
- specifications
  - 4xDMT **A-3**
  - 4xDMT over ISDN **A-4**
  - 4xflexi **A-4**
  - 4xSDSL **A-5**

8xDMT **A-6**  
 8xDMT over ISDN **A-7**  
 8xG.SHDSL **A-7**  
 DS3+T1/E1 IMA NI-2 card **A-9**  
 DS3/2DS3 NI-2 card **A-8**  
 fan tray **A-12**  
 I/O module **A-11**  
 management software **A-12**  
 OC-3c/OC-3c NI-2 card **A-10**  
 PEM **A-11**  
 stabilize and measure rack space **3-3, 4-2**  
 standard telco color chart **B-6**  
 subtended network configuration  
   DS3+T1/E1 IMA NI-2 cards **1-9**  
   DS3/2DS3 NI-2 cards **1-7**  
   OC-3c/OC-3c NI-2 cards **1-10**  
   redundancy **1-41**  
 subtending  
   E1 subtending configuration  
     illustration **4-18**  
   E3 subtending configuration  
     illustration **4-17**

---

## T

T1 network interface alarms **5-19**  
 temperature requirements **2-12**  
 timesaver, definition **xv**  
 tip, definition **xv**  
 troubleshooting  
   alarms **5-17**  
   basic checks **5-2**  
   contacting the Cisco TAC **5-2**  
   fan tray **5-15**  
   hot swapping **5-1**  
   I/O module problems **5-14**  
   line cards **5-10**  
   NI-2 card problems **5-8**  
   NI-2 redundancy **5-9**

PEM **5-16**

---

## U

unpacking the system **2-18**

---

## V

verifying contents **2-18**

---

## W

warning definition **xv**  
 wire-wrap pin mapping for I/O modules **C-3**  
 wire-wrap pins  
   I/O module **1-44**  
   pin assignments **1-45**  
 wire-wrap pins illustration **1-44**

---

## X

xTU-C line cards  
   installing **6-7**  
   removing **6-9**