



Hardware Note for Cisco 6732 Front Panel Installation

Cisco 6732 Front Panel

The following information provides instructions for installing the front panel on the Cisco 6732 chassis.

Figure 1 Cisco 6732 Front Panel and Cisco 6732 Chassis

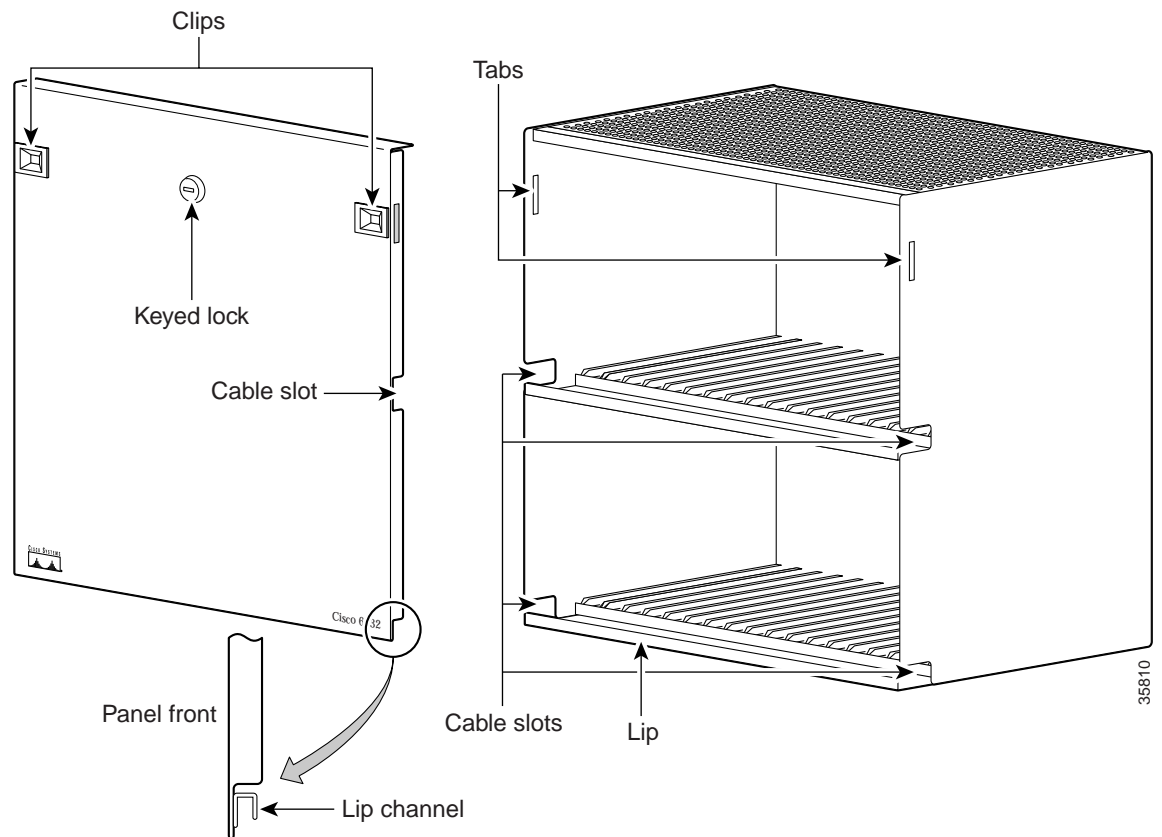



Note The Cisco 6732 Series chassis front panel is ordered as an accessory. To order the front panel use part number 6732-ACC-COVER=.

To install the front panel, perform the following steps:

- Step 1** Turn the key in the chassis lock so that the key is unlocked (see Figure 2).
Turning the key to the unlocked position causes the clips to retract and allows you to push the cover inside the chassis frame.
- Step 2** Place the lip channel of the front panel (see Figure 2) over the lip on the chassis frame.
- Step 3** Slowly move the panel back toward the chassis until it fits securely inside the chassis frame.



Note When you are moving the front panel back toward the chassis, make sure that the cables are placed in the cable slots so that they are not pinched by the closing panel (see Figure 3).

Figure 2 *Installing the Front Panel*

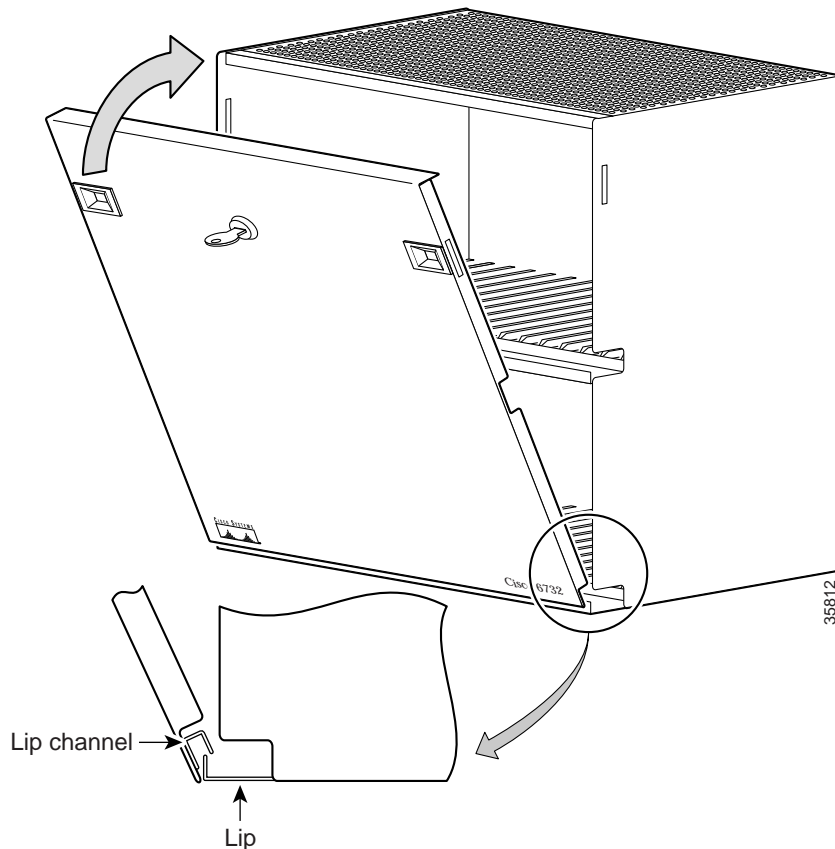

- Step 4** When the front panel fits securely inside the frame, turn the key to the locked position.
The clips slide into the tab slots and secure the front panel to the chassis.

Figure 3 Closed and Locked Cabinet

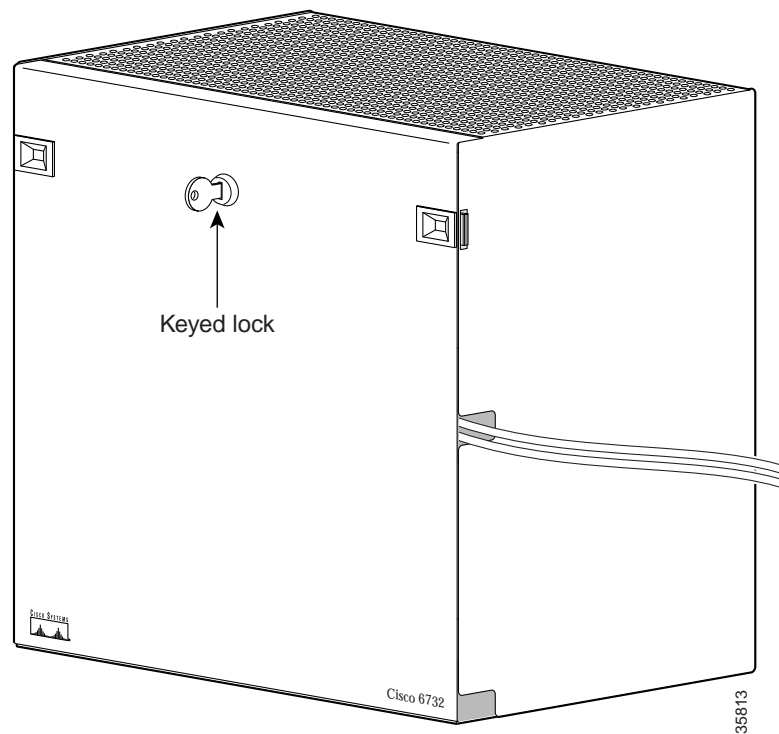

Related Documentation

Hardware Documents

Cisco 6732 Series Multiservice Access Platform Hardware Installation Guide

Obtaining Documentation

World Wide Web

You can access the most current Cisco documentation on the World Wide Web at <http://www.cisco.com>, <http://www-china.cisco.com>, or <http://www-europe.cisco.com>.

Documentation CD-ROM

Cisco documentation and additional literature are available in a CD-ROM package, which ships with your product. The Documentation CD-ROM is updated monthly. Therefore, it is probably more current than printed documentation. The CD-ROM package is available as a single unit or as an annual subscription.

Ordering Documentation

Registered CCO users can order the Documentation CD-ROM and other Cisco Product documentation through our online Subscription Services at <http://www.cisco.com/cgi-bin/subcat/kaojump.cgi>.

Nonregistered CCO users can order documentation through a local account representative by calling Cisco's corporate headquarters (California, USA) at 408 526-4000 or, in North America, call 800 553-NETS (6387).

Obtaining Technical Assistance

Cisco provides Cisco Connection Online (CCO) as a starting point for all technical assistance. Warranty or maintenance contract customers can use the Technical Assistance Center. All customers can submit technical feedback on Cisco documentation using the web, e-mail, a self-addressed stamped response card included in many printed docs, or by sending mail to Cisco.

Cisco Connection Online

Cisco continues to revolutionize how business is done on the Internet. Cisco Connection Online is the foundation of a suite of interactive, networked services that provides immediate, open access to Cisco information and resources at anytime, from anywhere in the world. This highly integrated Internet application is a powerful, easy-to-use tool for doing business with Cisco.

CCO's broad range of features and services helps customers and partners to streamline business processes and improve productivity. Through CCO, you will find information about Cisco and our networking solutions, services, and programs. In addition, you can resolve technical issues with online support services, download and test software packages, and order Cisco learning materials and merchandise. Valuable online skill assessment, training, and certification programs are also available.

Customers and partners can self-register on CCO to obtain additional personalized information and services. Registered users may order products, check on the status of an order and view benefits specific to their relationships with Cisco.

You can access CCO in the following ways:

- WWW: www.cisco.com
- Telnet: cco.cisco.com
- Modem using standard connection rates and the following terminal settings: VT100 emulation; 8 data bits; no parity; and 1 stop bit.
 - From North America, call 408 526-8070
 - From Europe, call 33 1 64 46 40 82

You can e-mail questions about using CCO to cco-team@cisco.com.

Obtaining Technical Assistance

Technical Assistance Center

The Cisco Technical Assistance Center (TAC) is available to warranty or maintenance contract customers who need technical assistance with a Cisco product that is under warranty or covered by a maintenance contract.

To display the TAC web site that includes links to technical support information and software upgrades and for requesting TAC support, use www.cisco.com/techsupport.

To contact by e-mail, use one of the following:

Language	E-mail Address
English	tac@cisco.com
Hanzi (Chinese)	chinese-tac@cisco.com
Kanji (Japanese)	japan-tac@cisco.com
Hangul (Korean)	korea-tac@cisco.com
Spanish	tac@cisco.com
Thai	thai-tac@cisco.com

In North America, TAC can be reached at 800 553-2447 or 408 526-7209. For other telephone numbers and TAC e-mail addresses worldwide, consult the following web site:
<http://www.cisco.com/warp/public/687/Directory/DirTAC.shtml>.

Documentation Feedback

If you are reading Cisco product documentation on the World Wide Web, you can submit technical comments electronically. Click **Feedback** in the tool bar and select **Documentation**. After you complete the form, click **Submit** to send it to Cisco.

You can e-mail your comments to bug-doc@cisco.com.

To submit your comments by mail, for your convenience many documents contain a response card behind the front cover. Otherwise, you can mail your comments to the following address:

Cisco Systems, Inc.
Document Resource Connection
170 West Tasman Drive
San Jose, CA 95134-9883

We appreciate and value your comments.

This document is to be used in conjunction with the documents listed in the "Related Documentation" section.

Access Registrar, AccessPath, Are You Ready, ATM Director, Browse with Me, CCDA, CCDE, CCDP, CCIE, CCNA, CCNP, CCSI, CD-PAC, *CiscoLink*, the Cisco NetWorks logo, the Cisco Powered Network logo, Cisco Systems Networking Academy, Fast Step, FireRunner, Follow Me Browsing, FormShare, GigaStack, IGX, Intelligence in the Optical Core, Internet Quotient, IP/VC, iQ Breakthrough, iQ Expertise, iQ FastTrack, iQuick Study, iQ Readiness Scorecard, The iQ Logo, Kernel Proxy, MGX, Natural Network Viewer, Network Registrar, the Networkers logo, *Packet*, PIX, Point and Click Internetworking, Policy Builder, RateMUX, ReyMaster, ReyView, ScriptShare, Secure Script, Shop with Me, SlideCast, SMARTnet, SVX, TrafficDirector, TransPath, VlanDirector, Voice LAN, Wavelength Router, Workgroup Director, and Workgroup Stack are trademarks of Cisco Systems, Inc.; Changing the Way We Work, Live, Play, and Learn, Empowering the Internet Generation, are service marks of Cisco Systems, Inc.; and Aironet, ASIST, BPX, Catalyst, Cisco, the Cisco Certified Internetwork Expert Logo, Cisco IOS, the Cisco IOS logo, Cisco Press, Cisco Systems, Cisco Systems Capital, the Cisco Systems logo, Collision Free, Enterprise/Solver, EtherChannel, EtherSwitch, FastHub, FastLink, FastPAD, IOS, IP/TV, IPX, LightStream, LightSwitch, MICA, NetRanger, Post-Routing, Pre-Routing, Registrar, StrataView Plus, Stratm, SwitchProbe, TeleRouter, are registered trademarks of Cisco Systems, Inc. or its affiliates in the U.S. and certain other countries.

All other brands, names, or trademarks mentioned in this document/website are the property of their respective owners. The use of the word partner does not imply a partnership relationship between Cisco and any of its resellers. (0008R)

Copyright © 1999, Cisco Systems, Inc.
All rights reserved.