



Cisco VCO/4K Mechanical Assemblies

Software Release V5.1
August 2000

Corporate Headquarters

Cisco Systems, Inc.
170 West Tasman Drive
San Jose, CA 95134-1706
USA

<http://www.cisco.com>

Tel: 408 526-4000
800 553-NETS (6387)

Fax: 408 526-4100

THE SPECIFICATIONS AND INFORMATION REGARDING THE PRODUCTS IN THIS MANUAL ARE SUBJECT TO CHANGE WITHOUT NOTICE. ALL STATEMENTS, INFORMATION, AND RECOMMENDATIONS IN THIS MANUAL ARE BELIEVED TO BE ACCURATE BUT ARE PRESENTED WITHOUT WARRANTY OF ANY KIND, EXPRESS OR IMPLIED. USERS MUST TAKE FULL RESPONSIBILITY FOR THEIR APPLICATION OF ANY PRODUCTS.

THE SOFTWARE LICENSE AND LIMITED WARRANTY FOR THE ACCOMPANYING PRODUCT ARE SET FORTH IN THE INFORMATION PACKET THAT SHIPPED WITH THE PRODUCT AND ARE INCORPORATED HEREIN BY THIS REFERENCE. IF YOU ARE UNABLE TO LOCATE THE SOFTWARE LICENSE OR LIMITED WARRANTY, CONTACT YOUR CISCO REPRESENTATIVE FOR A COPY.

The following information is for FCC compliance of Class A devices: This equipment has been tested and found to comply with the limits for a Class A digital device, pursuant to part 15 of the FCC rules. These limits are designed to provide reasonable protection against harmful interference when the equipment is operated in a commercial environment. This equipment generates, uses, and can radiate radio-frequency energy and, if not installed and used in accordance with the instruction manual, may cause harmful interference to radio communications. Operation of this equipment in a residential area is likely to cause harmful interference, in which case users will be required to correct the interference at their own expense.

The following information is for FCC compliance of Class B devices: The equipment described in this manual generates and may radiate radio-frequency energy. If it is not installed in accordance with Cisco's installation instructions, it may cause interference with radio and television reception. This equipment has been tested and found to comply with the limits for a Class B digital device in accordance with the specifications in part 15 of the FCC rules. These specifications are designed to provide reasonable protection against such interference in a residential installation. However, there is no guarantee that interference will not occur in a particular installation.

Modifying the equipment without Cisco's written authorization may result in the equipment no longer complying with FCC requirements for Class A or Class B digital devices. In that event, your right to use the equipment may be limited by FCC regulations, and you may be required to correct any interference to radio or television communications at your own expense.

You can determine whether your equipment is causing interference by turning it off. If the interference stops, it was probably caused by the Cisco equipment or one of its peripheral devices. If the equipment causes interference to radio or television reception, try to correct the interference by using one or more of the following measures:

- Turn the television or radio antenna until the interference stops.
- Move the equipment to one side or the other of the television or radio.
- Move the equipment farther away from the television or radio.
- Plug the equipment into an outlet that is on a different circuit from the television or radio. (That is, make certain the equipment and the television or radio are on circuits controlled by different circuit breakers or fuses.)

Modifications to this product not authorized by Cisco Systems, Inc. could void the FCC approval and negate your authority to operate the product.

The Cisco implementation of TCP header compression is an adaptation of a program developed by the University of California, Berkeley (UCB) as part of UCB's public domain version of the UNIX operating system. All rights reserved. Copyright © 1981, Regents of the University of California.

NOTWITHSTANDING ANY OTHER WARRANTY HEREIN, ALL DOCUMENT FILES AND SOFTWARE OF THESE SUPPLIERS ARE PROVIDED "AS IS" WITH ALL FAULTS. CISCO AND THE ABOVE-NAMED SUPPLIERS DISCLAIM ALL WARRANTIES, EXPRESSED OR IMPLIED, INCLUDING, WITHOUT LIMITATION, THOSE OF MERCHANTABILITY, FITNESS FOR A PARTICULAR PURPOSE AND NONINFRINGEMENT OR ARISING FROM A COURSE OF DEALING, USAGE, OR TRADE PRACTICE.

IN NO EVENT SHALL CISCO OR ITS SUPPLIERS BE LIABLE FOR ANY INDIRECT, SPECIAL, CONSEQUENTIAL, OR INCIDENTAL DAMAGES, INCLUDING, WITHOUT LIMITATION, LOST PROFITS OR LOSS OR DAMAGE TO DATA ARISING OUT OF THE USE OR INABILITY TO USE THIS MANUAL, EVEN IF CISCO OR ITS SUPPLIERS HAVE BEEN ADVISED OF THE POSSIBILITY OF SUCH DAMAGES.

Access Registrar, AccessPath, Any to Any, Are You Ready, AtmDirector, Browse with Me, CCDA, CCDE, CCDP, CCIE, CCNA, CCNP, CCSI, CD-PAC, the Cisco logo, Cisco Certified Internetwork Expert logo, *CiscoLink*, the Cisco Management Connection logo, the Cisco NetWorks logo, the Cisco Powered Network logo, Cisco Systems Capital, the Cisco Systems Capital logo, Cisco Systems Networking Academy, the Cisco Systems Networking Academy logo, the Cisco Technologies logo, Fast Step, FireRunner, Follow Me Browsing, FormShare, GigaStack, IGX, Intelligence in the Optical Core, Internet Quotient, IP/VC, IQ Breakthrough, IQ Expertise, IQ FastTrack, IQ Readiness Scorecard, The IQ Logo, Kernel Proxy, MGX, Natural Network Viewer, NetSonar, Network Registrar, the Networkers logo, *Packet*, PIX, Point and Click Internetworking, Policy Builder, Precept, RateMux, ReyMaster, ReyView, ScriptShare, Secure Script, Shop with Me, SlideCast, SMARTnet, SVX, *The Cell*, TrafficDirector, TransPath, VlanDirector, Voice LAN, Wavelength Router, Workgroup Director, and Workgroup Stack are trademarks; Changing the Way We Work, Live, Play, and Learn, Empowering the Internet Generation, The Internet Economy, and The New Internet Economy are service marks; and Aironet, ASIST, BPX, Catalyst, Cisco, Cisco IOS, the Cisco IOS logo, Cisco Systems, the Cisco Systems logo, the Cisco Systems Cisco Press logo, CollisionFree, Enterprise/Solver, EtherChannel, EtherSwitch, FastHub, FastLink, FastPAD, FastSwitch, GeoTel, IOS, IP/TV, IPX, LightStream, LightSwitch, MICA, NetRanger, Post-Routing, Pre-Routing, Registrar, StrataView Plus, Stratm, TeleRouter, and VCO are registered trademarks of Cisco Systems, Inc. or its affiliates in the U.S. and certain other countries. All other trademarks mentioned in this document are the property of their respective owners. The use of the word partner does not imply a partnership relationship between Cisco and any other company. (0005R)

Cisco VCO/4K Mechanical Assemblies
Copyright © 2000, Cisco Systems, Inc.
All rights reserved.

VCO/4K MECHANICAL ASSEMBLIES OVERVIEW

1.0 INTRODUCTION	1
2.0 CISCO CONNECTION ONLINE	1
3.0 TECHNICAL ASSISTANCE CENTER	2

SYSTEM ENCLOSURE

1.0 GENERAL	1
2.0 SPECIFICATIONS	3
3.0 COMPONENT DESCRIPTION	3
3.1 Front Door	4
3.2 Mounting Options	5
4.0 MOVING THE SYSTEM ENCLOSURE	6
5.0 TROUBLESHOOTING	7
6.0 RELATED DOCUMENTS	7

FAN UNIT

1.0 GENERAL	1
2.0 SPECIFICATIONS	1
3.0 COMPONENT DESCRIPTION	2
4.0 THE FAN CONTROLLER CARDS	5
4.1 Operation	5
4.2 Alarm Indicator	5
5.0 REMOVAL/REPLACEMENT PROCEDURES	6
5.1 Removal Procedures	6
5.2 Replacement Procedures	7
6.0 TROUBLESHOOTING	7
6.1 Fan Failure	7
6.2 Power Failure	8
6.3 Fan Failure Problem Fails to be Detected by LED or AAC	8
7.0 RELATED DOCUMENTS	8

VCO/4K POWER SUBSYSTEM

1.0 GENERAL DESCRIPTION	1
2.0 SPECIFICATIONS	3
2.1 Specifications for Power Entry Module	3
2.2 Specifications for Power Supply Module	3
2.3 Specifications for Ring Generator (optional)	3

3.0 POWER ENTRY MODULE	4
3.1 Input Power	5
3.2 Indicator LEDs	7
Power LED	7
Ring Generator LED	7
3.3 Interlock Switch	8
4.0 INPUT AND OUTPUT POWER DISTRIBUTION	9
4.1 Output Power Redundancy and Load Sharing	11
5.0 RING GENERATOR	12
6.0 REMOVAL AND REPLACEMENT PROCEDURES	13
6.1 To Remove a Power Supply Module	13
To remove a nonredundant power supply module:	13
To remove a redundant power supply module:	14
6.2 To Replace a Power Supply Module	14
7.0 TROUBLESHOOTING	15
7.1 Alarms	15
7.2 Spare Fuse Kit	15
8.0 RELATED DOCUMENTS	15

STORAGE/CONTROL I/O MODULE

1.0 GENERAL	1
2.0 SPECIFICATIONS	1
3.0 DESCRIPTION	2
3.1 Front Panel Indicators and Ports Assignments	2
3.2 Hard Disk Drive	4
3.3 Midplane Connectors	6
3.4 Serial Ports 1 and 2	6
3.5 Serial Ports 3 and 4	8
3.6 Ethernet Interface	10
3.7 Printer Interface	11
3.8 SCSI Interface	11
4.0 HARDWARE CONFIGURATION	12
4.1 SCSI Termination Configuration	12
4.2 Serial Port Configuration	12
Serial Ports 1 through 4 and Jumper Settings	12
Serial Ports 1 through 4	13
5.0 REMOVAL/REPLACEMENT INFORMATION	16
Nonredundant Systems	17
Redundant Systems	17
5.1 Removal Procedures	17
5.2 Replacement Procedures	18

6.0 TROUBLESHOOTING	19
LEDs Not Illuminated	19
Troubleshooting Reference Materials	19
7.0 RELATED DOCUMENTS	19

I/O MODULES

1.0 GENERAL	1
2.0 RJ11X I/O MODULE SPECIFICATIONS	1
2.1 RJ-11X I/O Module Descriptions	2
3.0 RJ-21X I/O MODULE	4
3.1 RJ-21X I/O Module Descriptions	5
4.0 RJ-2NX I/O MODULE	9
4.1 Specifications	9
4.2 RJ-2EX, RJ-2FX, and RJ-2GX I/O Module Descriptions	10
4.3 RJ-2HX I/O Module Description	14
5.0 RJ-45/DB-15 I/O MODULE	16
5.1 Specifications	16
5.2 RJ-45/DB-15 I/O Module for Single Span T1	17
5.3 RJ-45/DB-15 I/O Module for Four Span T1	19
6.0 BNC I/O MODULE	21
6.1 Specifications	21
6.2 BNC I/O Module For Single Span E1	22
6.3 BNC I/O Module For Four Span E1	24
7.0 REMOVAL AND REPLACEMENT PROCEDURES	26
7.1 Removing an I/O Module	26
7.2 Adding or Replacing an I/O Module	26
8.0 TROUBLESHOOTING	26

Technical Descriptions

VCO/4K Mechanical Assemblies Overview

1.0 INTRODUCTION

The *Cisco VCO/4K Mechanical Assemblies* describe the physical architecture and assemblies of a VCO/4K system, including system enclosures, subracks, power subsystems, storage subsystems, and other general system components.

Each technical description in this series reflects the most current information available about the product. The information contained in a technical description is specific to a single component within a system. Other system documents point to technical descriptions as containing the most detailed information available for a component.

A technical description contains information to service and maintain the component. For system-level servicing, refer to the *Cisco VCO/4K System Maintenance Manual*. The maintenance manual assists in isolating the cause of a system malfunction and serves as a pathfinder to the more detailed information contained in technical descriptions.

2.0 CISCO CONNECTION ONLINE

Cisco continues to revolutionize how business is done on the Internet. Cisco Connection Online is the foundation of a suite of interactive, networked services that provides immediate, open access to Cisco information and resources at anytime, from anywhere in the world. This highly integrated Internet application is a powerful, easy-to-use tool for doing business with Cisco.

CCO's broad range of features and services helps customers and partners to streamline business processes and improve productivity. Through CCO, you will find information about Cisco and our networking solutions, services, and programs. In addition, you can resolve technical issues with online support services, download and test software packages, and order Cisco learning materials and merchandise. Valuable online skill assessment, training, and certification programs are also available.

Customers and partners can self-register on CCO to obtain additional personalized information and services. Registered users may order products, check on the status of an order and view benefits specific to their relationships with Cisco.

You can access CCO in the following ways:

- WWW: www.cisco.com
- Telnet: [cco.cisco.com](telnet://cco.cisco.com)
- Modem using standard connection rates and the following terminal settings:
VT100 emulation; 8 data bits; no parity; and 1 stop bit.

From North America, call 408 526-8070

From Europe, call 33 1 64 46 40 82

You can e-mail questions about using CCO to cco-team@cisco.com.

3.0 TECHNICAL ASSISTANCE CENTER

The Cisco Technical Assistance Center (TAC) is available to warranty or maintenance contract customers who need technical assistance with a Cisco product that is under warranty or covered by a maintenance contract.

To display the TAC web site that includes links to technical support information and software upgrades and for requesting TAC support, use www.cisco.com/techsupport.

To contact by e-mail, use one of the following:

Language	E-mail Address
English	tac@cisco.com
Hanzi (Chinese)	chinese-tac@cisco.com
Kanji (Japanese)	japan-tac@cisco.com
Hangul (Korean)	korea-tac@cisco.com
Spanish	tac@cisco.com
Thai	thai-tac@cisco.com

In North America, TAC can be reached at 800 553-2447 or 408 526-7209. For other telephone numbers and TAC e-mail addresses worldwide, consult the following web site:
<http://www.cisco.com/warp/public/687/Directory/DirTAC.shtml>.

Technical Description

System Enclosure

1.0 GENERAL

The VCO/4K system enclosure is a metal-based cabinet that houses all the VCO/4K critical system components including: the fan cooling unit; the alarm arbiter and interface cards; and high-density system hardware cards. It also accommodates the power subsystem, either single or dual for system redundancy. *Figure 1* shows the front of a VCO/4K system. *Figure 2* shows a cutaway view of the chassis underneath the enclosure.

The system enclosure is designed and manufactured to meet or exceed the following enclosure requirements:

- *UL 1950 Standard for Information Technology Equipment*
- *Network Equipment-Building System (NEBS) GR-63-CORE with Zone 4 Earthquake and Bellcore's GR-1089-CORE Safety and Physical Protection*
- *General safety, including UL/CUL and EMI/EMC FCC Part 15*



Figure 1: VCO/4K System

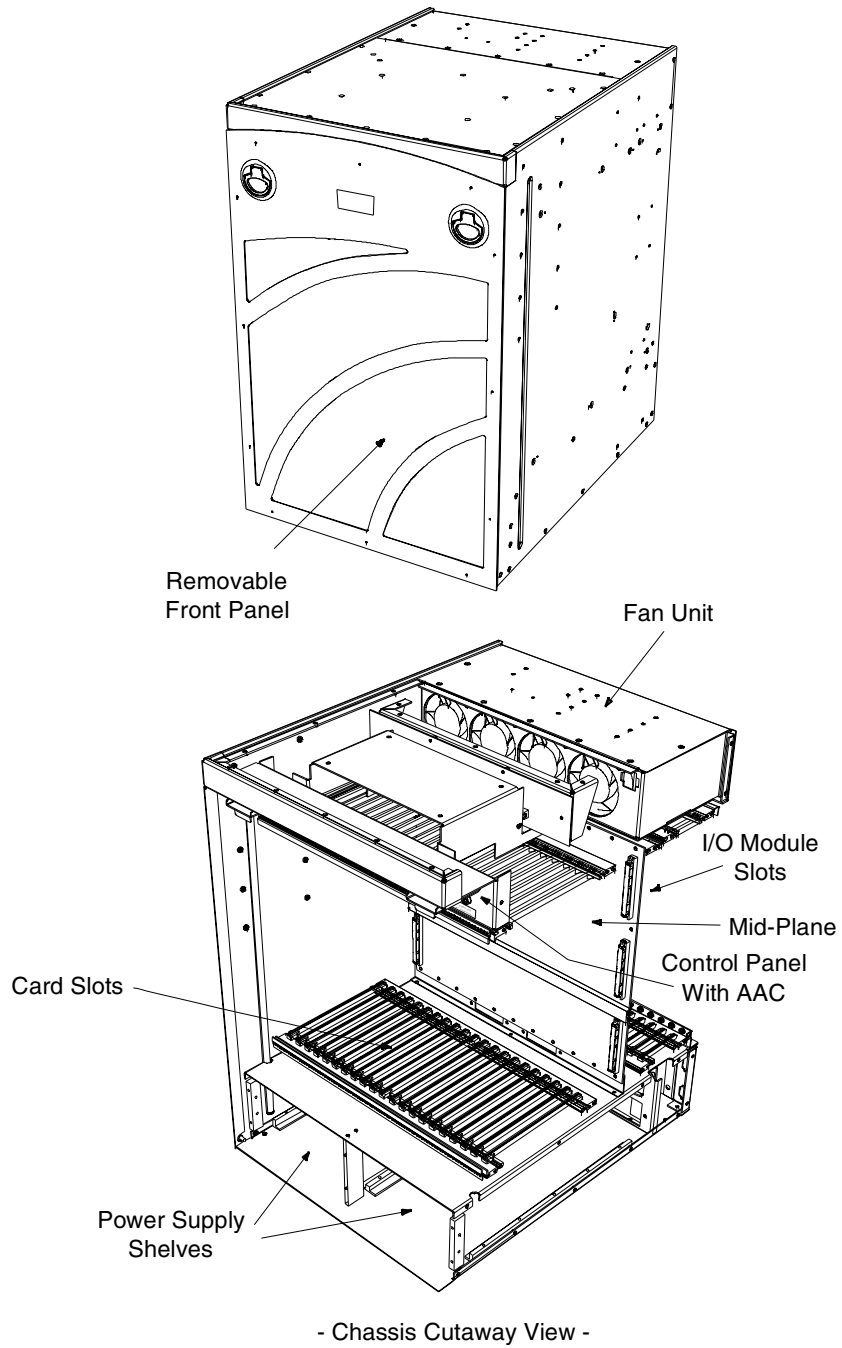

Figure 2: VCO/4K Switch Enclosure and Chassis

2.0 SPECIFICATIONS

Part Number:	Contact your Cisco Systems sales representative
Front Door:	Removable front door with locking feature
Enclosure Dimensions:	Height — 26.13 inch (67.73 cm) Width — 17.5 inch (45.33 cm) Depth — 22.5 inch (58.57 cm)
Footprint:	22.50 in. by 17.5 in. (57.15 cm by 45.33 cm)

3.0 COMPONENT DESCRIPTION

The VCO/4K system enclosure is designed for environments that require UL 1950 enclosures. Venting holes on the front door provide air flow to cool system components when the system fan units are operational. A removable air filter is held in place by a cross member and two screws on the inside of the front door. Four screw-in rubber foot pads for bench use are provided as an option. All cable access is through the back of the system enclosure. *Figure 3* shows the front of a VCO/4K with the door off. *Figure 4* shows the back of the system enclosure.

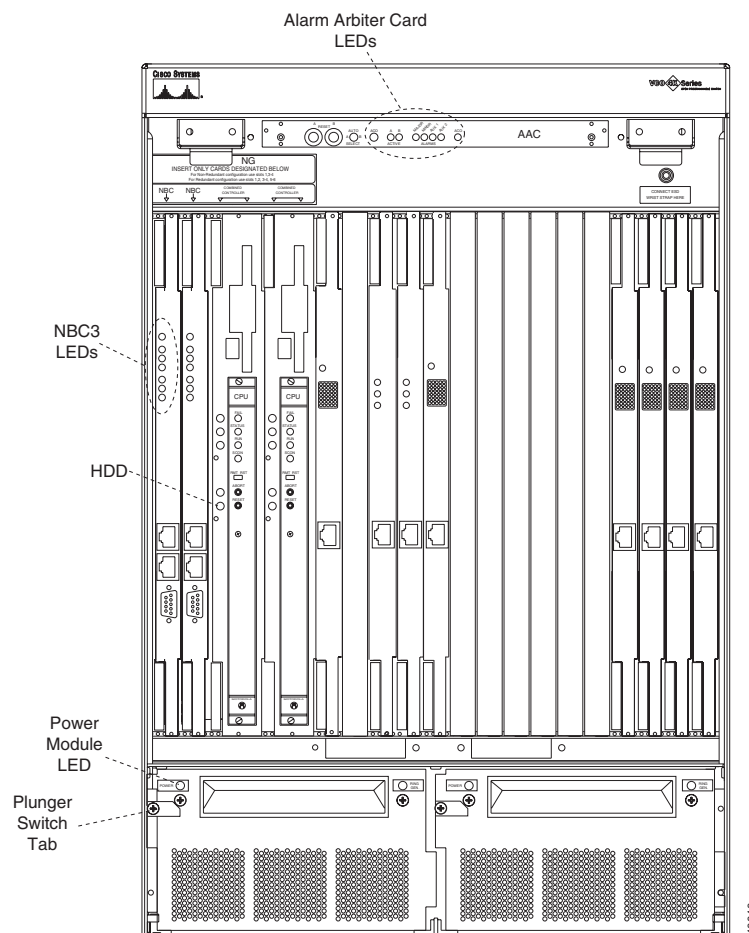

Figure 3: VCO/4K System (Front View—Door Off)

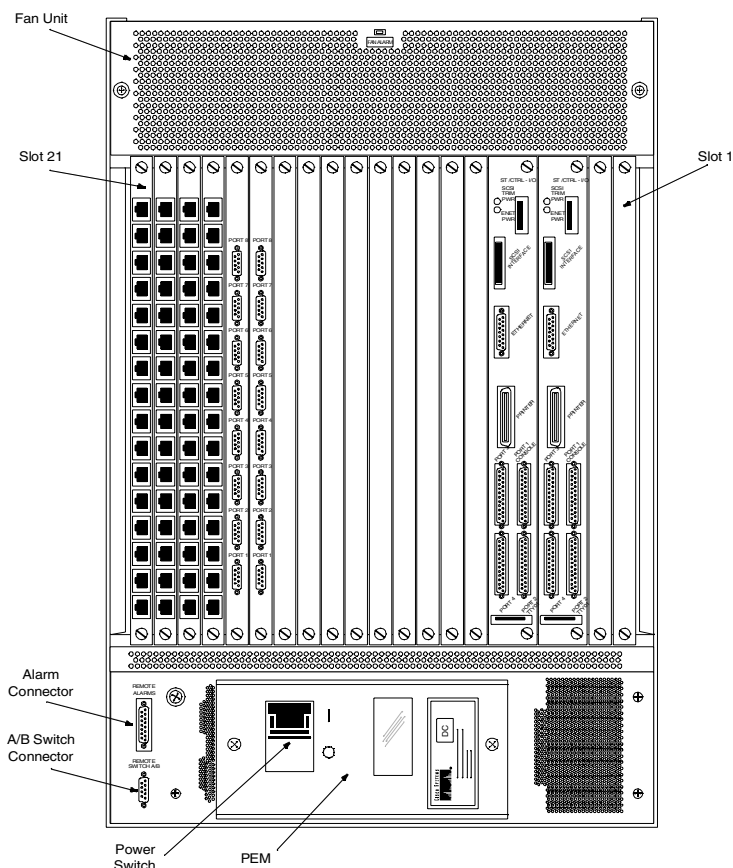

Figure 4: VCO/4K System (Back View)

3.1 Front Door

The VCO/4K front door has a lock for security purposes. Two door frame latches at the top and two studs at the bottom hold the door in place. **The front door must remain on during system operation for NEBS EMI compliance.**

The inside of the door contains an air filter made of UL 94 HF-1 foam. The removable air filter should be regularly vacuumed to remove any accumulated dust.

To remove the front door:

1. If necessary, unlock front door. The lock is located at the center of the door between the door latches.
2. Flip up the two door latches located to the right and left of the lock. Hold the latches and pull the door approximately three inches away from the system enclosure. Grasp the sides of the door and lift it up and away to clear the studs located at the base of the enclosure.
3. Carefully remove the door and place it in an area where it will not become damaged.

To install the front door:

1. Grasp the sides of the door and position it so that the bottom is aligned with the studs located at the base of the enclosure.
2. Flip up the two door latches located to the right and left of the lock. Hold the latches in the open position and push the door toward the system enclosure until it snaps closed. Press the door latches in.
3. Lock the door.

CAUTION: To ensure security, always lock the front door of the enclosure after you have performed service procedures.

3.2 Mounting Options

The VCO/4K may be installed in an EIA standard cabinet that is 19 inches wide. If the VCO/4K will be installed in a cabinet or rack, a mounting shelf must be secured to the cabinet/rack and a mounting brace must be secured to the VCO/4K before it is lifted and placed in the cabinet or rack. *Figure 5* shows the mounting brace (one on each side) for the VCO/4K.

Refer to the *Cisco VCO/4K Site Preparation Guide* for specifications on the mounting brace and shelf. Refer to the *Cisco VCO/4K Installation Manual* for information on attaching the mounting brace and shelf.

Two rear support holes are located at the base of the each side panel. You have the option of fabricating and attaching brackets for additional support when mounting the VCO/4K in a cabinet or rack.

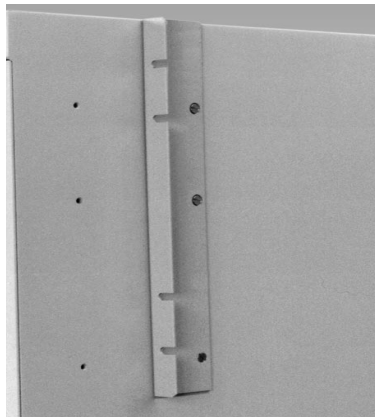

Figure 5: Mounting Brace

4.0 MOVING THE SYSTEM ENCLOSURE

If the VCO/4K is mounted in a cabinet or rack, it must be removed from the cabinet/rack before moving it to another location.

CAUTION: Follow ESD rules when removing system components. Be sure to use a wrist strap for grounding. At least two people are required to move the system enclosure.

To move the system enclosure:

1. Power down the system by turning off the power switch at the rear of the enclosure.
2. Disconnect the power connector from the power entry module.
3. Remove the EIA/TIA-232 serial cables, parallel printer cables, and optional Ethernet transceiver cables connected to the rack. Be sure that all EIA/TIA-232 cables are properly labeled so that they can be rerouted and re-installed, as necessary.
4. Remove the network cables from the I/O modules. Be sure that all cables are properly labeled so that they can be rerouted and re-installed as necessary.
5. Disconnect earth ground to the system at the ground point within the enclosure.
6. Remove the power supply module(s) to decrease the weight of the system. Refer to the *Cisco VCO/4K Mechanical Assemblies: VCO/4K Power Subsystem* for more information.
7. If the VCO/4K is installed in a cabinet or rack, remove the VCO/4K from the cabinet/rack.

CAUTION: At least two people are required to move the system enclosure.

8.
 - a. To move the system to another location in the same room, lift it into position.
 - b. To move the system to another location outside the room, repack the system enclosure, including the power supply modules, in the original shipping container.

The VCO/4K system enclosure must be installed to meet the clearance, environmental, and power criteria specified in the *Cisco VCO/4K Site Preparation Guide*. To reinstall the system enclosure, follow the procedures in the *Cisco VCO/4K Hardware Installation Manual*.

5.0 TROUBLESHOOTING

The system enclosure provides passive mechanical and electrical connections to the card rack and power subsystem. It is highly unlikely that the system enclosure will cause a system failure in the course of normal operation. The most likely cause of damage to a system enclosure is mechanical damage resulting in a misalignment of racks or an electrical short circuit within the inter-rack cabling. More specific causes of damage include:

- Bumping into the enclosure
- Sudden or sharp pulling on network or EIA/TIA-232 cables attached to the I/O modules
- Electrical surge or short circuit at power input feeds
- Short circuit caused by placing or dropping a conductive tool (i.e., screwdriver or pliers) in the enclosure
- Electrical surge induced through network connections caused by lightning or high voltage cross-connection through the MDF/digital cross connector.

To minimize any chance of mechanical or electrical damage to the enclosure, follow the recommended system clearances and central office practices for handling the MDF/digital cross connectors and power connections. If mechanical or electrical damage does occur, refer to the troubleshooting information in the appropriate Cisco Systems technical description for the damaged component.

6.0 RELATED DOCUMENTS

For additional information regarding the installation and maintenance of the VCO/4K system enclosure, refer to the following Cisco Systems publications:

- *Cisco VCO/4K Product Overview*
- *Cisco VCO/4K Site Preparation Guide*
- *Cisco VCO/4K Hardware Planning Guide*
- *Cisco VCO/4K Hardware Installation Manual*
- *Cisco VCO/4K System Maintenance Manual*

RELATED DOCUMENTS

Technical Description

Fan Unit

1.0 GENERAL

This Technical Description describes fan units used in the VCO/4K system. The fan unit draws hot air from inside the VCO/4K and discharges it through the rear of the VCO/4K enclosure. The fan unit has an alarm indicator (LED) that illuminates when any of the four cooling fans has failed.

Power is provided to the fan unit from the power backplane. The fan unit is powered automatically when one or both Power Supply Modules is powered on.

The fan unit consists of an aluminum tray that holds the following components:

- Eight 12Vdc cooling fans
- Three controller cards
- One temperature-sensitive thermal link (fuse)
- One LED indicator

2.0 SPECIFICATIONS

Part Number	Contact your Cisco Systems sales representative
Indicator LED	Fan Alarm
Fan Type	Brushless, 47 cfm, 12Vdc
Power	6 -15vdc, 24 watts
Physical Dimensions	Height: 3.5 inches Width: 17.5 inches Depth: 7.0 inches

3.0 COMPONENT DESCRIPTION

The fan unit is in the top 2U of the VCO/4K. When the system is powered on, the fan unit draws hot air from inside the VCO/4K and discharges it through the rear of the system's enclosure.

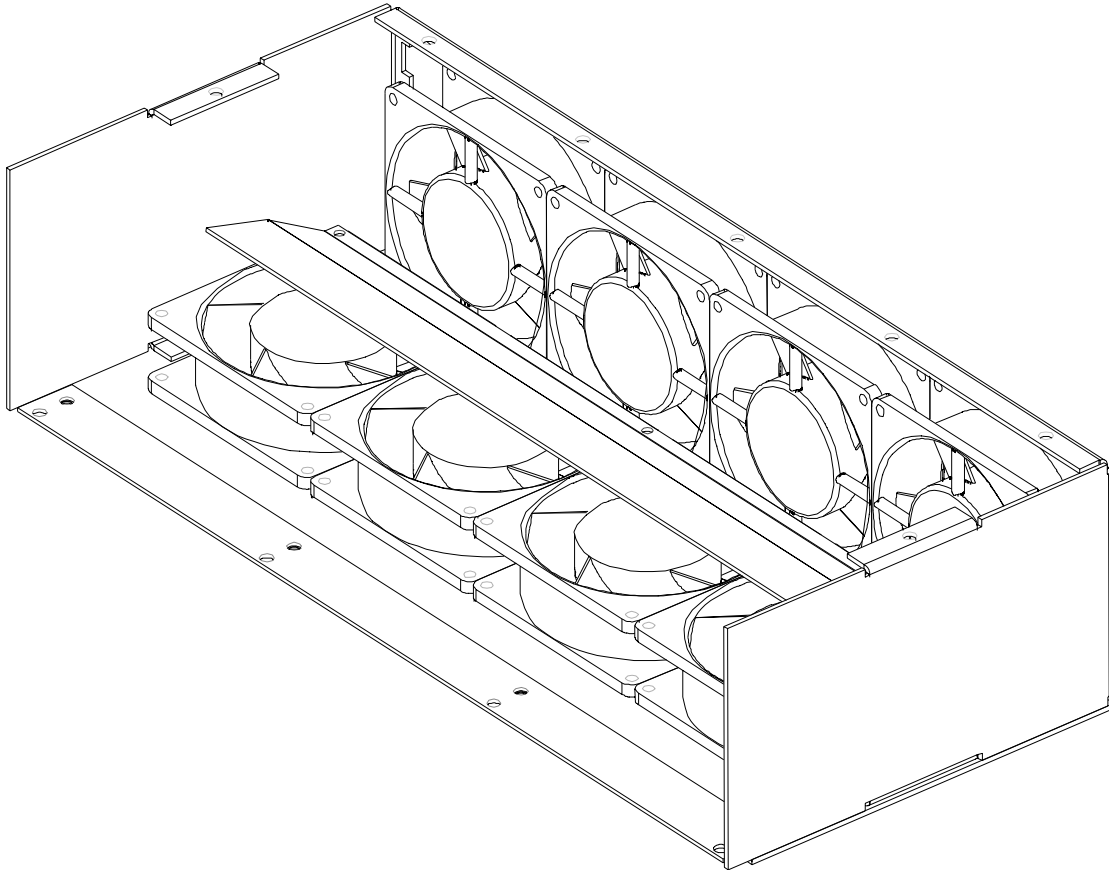

Figure 1: Fan Unit – Internal View

Note that the rear of the fan unit refers to the part of the unit which is *not* visible when the unit is installed in the VCO/4K. When installed, the rear of the fan unit is facing the front of the system's enclosure.

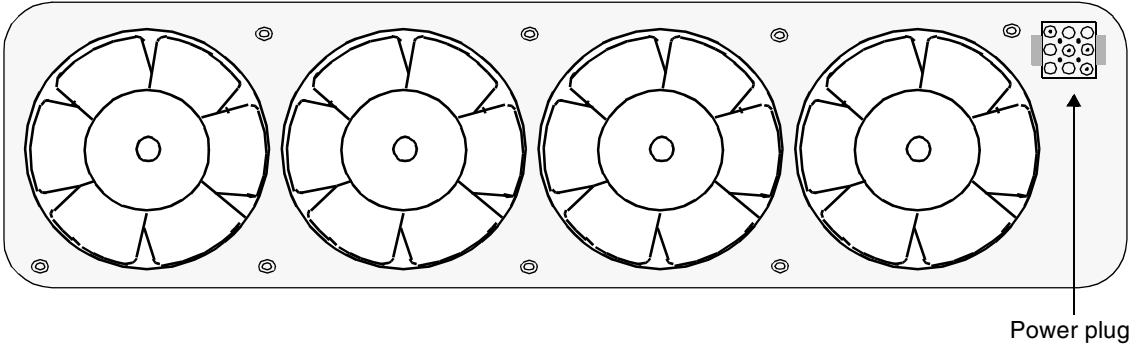

Figure 2: Fan Unit – Rear View

The front of the fan unit refers to the part of the unit which is visible when the unit is installed in the VCO/4K. The front is visible when looking in the rear of the system's enclosure.

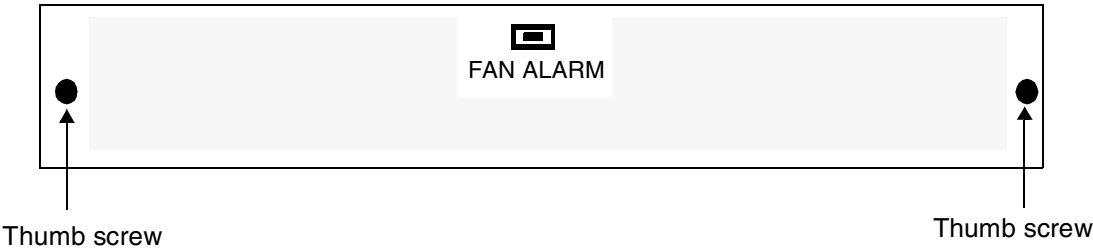

Figure 3: Fan Unit – Front View

Figure 4 shows a cutaway view of the chassis and where the fan unit resides.

COMPONENT DESCRIPTION

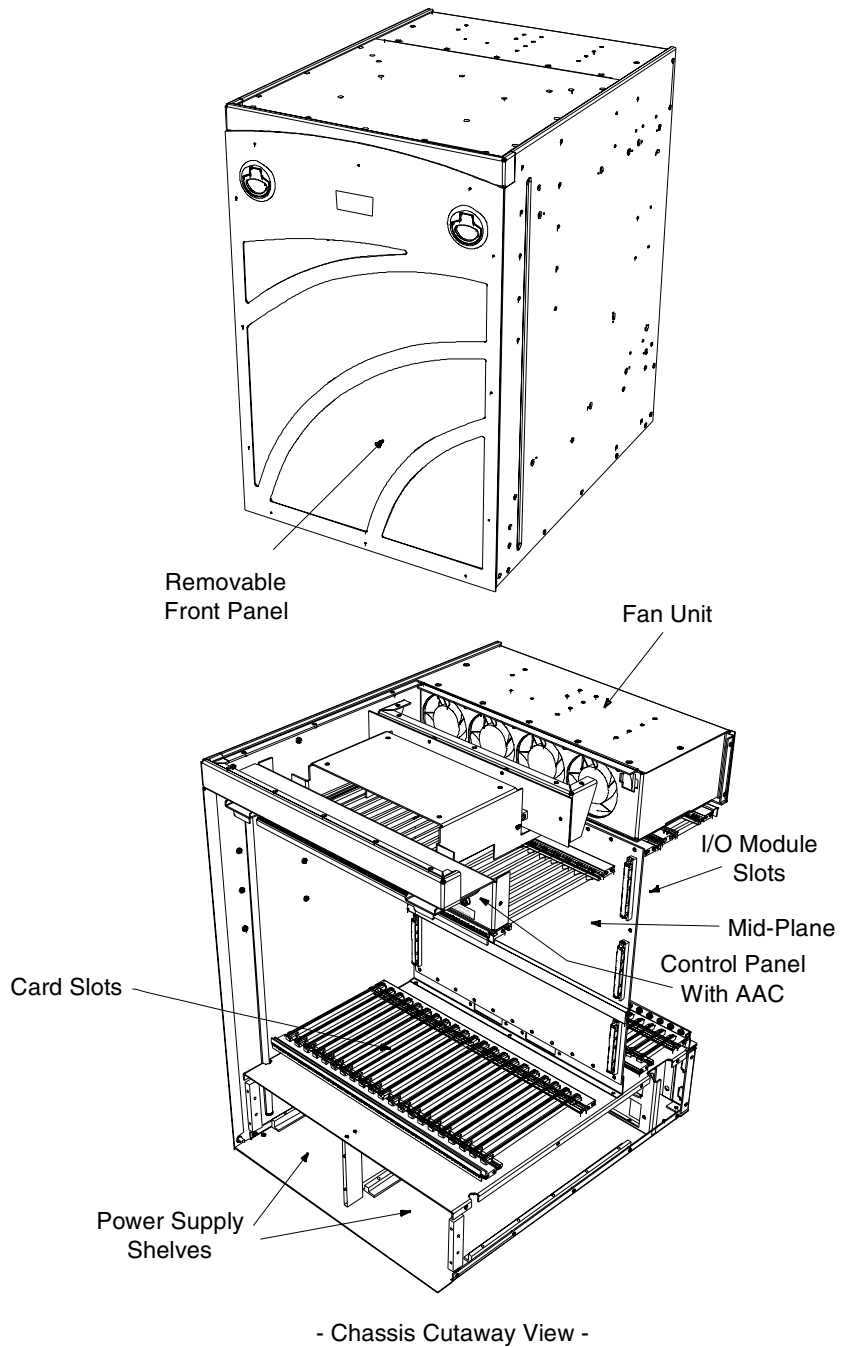

Figure 4: VCO/4K Switch Enclosure and Fan Location

4.0 THE FAN CONTROLLER CARDS

The fan unit contains three controller cards located between the fans and the front panel, inside the tray. Power is supplied to the fan unit from the VCO/4K's power backplane through the plug located on the rear right side of the unit. Power goes onto the fan control cards through the J5 connectors. Refer to *Figure 5*.

4.1 Operation

The fan unit operates whenever at least one power module is powered on. If no power modules are on, or if the power connector is not plugged in, the fans do not run.

The power plug on the fan unit supplies power to the two fan control cards through the J5 connectors. The J1 and J2 connectors on the fan control cards supply power to the fans. Refer to *Figure 5*.

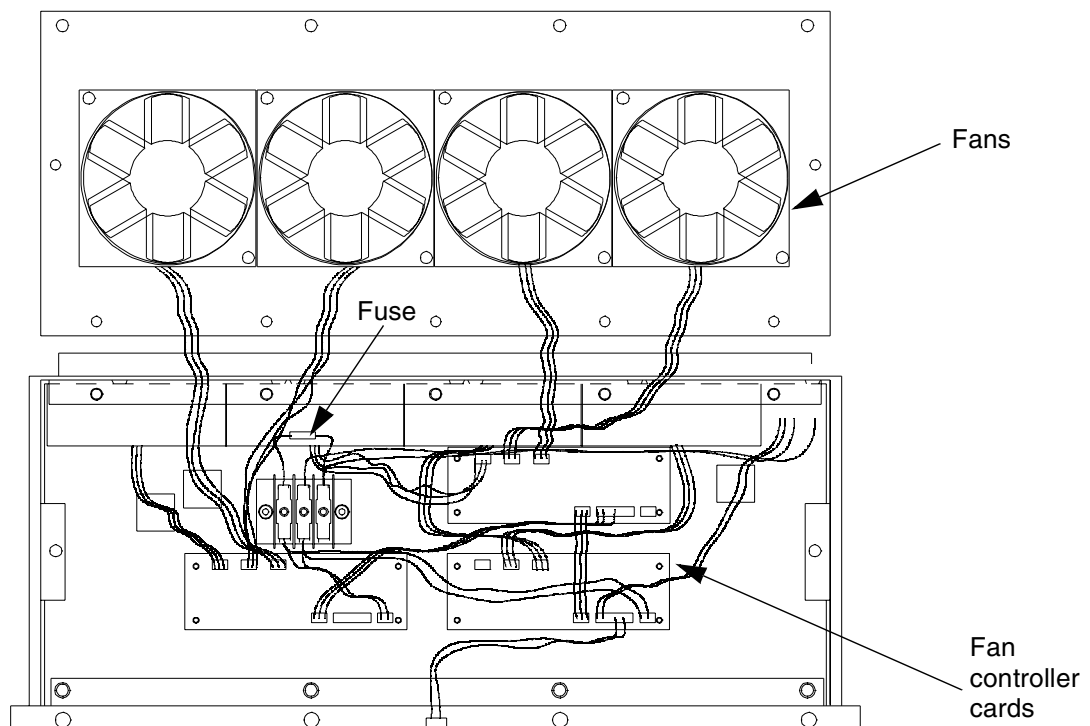

Figure 5: Fan Unit - Internal Wiring and Pin Locations

4.2 Alarm Indicator

The fan control card monitors its own cooling fans. If current fails to flow through any of its fans, the FAN ALARM LED is illuminated and a signal is sent to the AAC to trip MAJOR and AUX1 alarms.

5.0 REMOVAL/REPLACEMENT PROCEDURES

Only replace your fan unit in the event of a fan or fan-control card failure. The VCO/4K system can operate without severe damage if up to two fans fail. However, replace your fan unit as soon as possible. Call Cisco Systems for a replacement as soon as you detect a failure, or replace the unit immediately with a spare unit if it is available.

CAUTION: Do not operate the VCO/4K without the fan unit or if more than two fans have failed unless it is being removed and replaced in one operation.

5.1 Removal Procedures

You can remove fan units while the system is operating. If the unit is removed while the system is operating, caution must be taken to ensure that no objects become lodged or tangled in the operating fans while the unit is being removed. To remove a fan unit:

1. Unscrew the thumb screws located on the right and left sides of the fan unit. Refer to *Figure 3*.
2. Slide the fan unit directly back about half way.
CAUTION: Do not fully remove the fan unit from the VCO/4K until the power supply plug on the fan unit has been disconnected.
3. While the unit rests on the shelf, locate the power supply plug on the back, left side of the fan unit. Squeeze the sides of the plug to release it and disconnect the plug.
4. After disconnecting the power supply, grasp the fan unit on both sides and continue sliding it out until it is clear of the system enclosure.
5. Pack and ship the fan unit to Cisco Systems for service.

NOTE: Individual components of the fan unit are not field replaceable.

5.2 Replacement Procedures

Fan units can be replaced while the system continues to operate. If the unit is replaced while the system is operating, caution must be taken to ensure that no objects can become lodged or tangled in the fans when they begin to operate during the replacement procedure (step 3.)

To replace a fan unit:

1. Unpack the replacement fan unit. Be sure all packing materials have been removed.
2. Lift the fan unit into position so the top of the unit is flush with the top of the VCO/4K enclosure, and guide about half-way into the system enclosure. If the unit cannot be guided or lifted into the enclosure, make certain that the top of the unit has been correctly positioned.
3. Connect the power supply located on the back, left side of the fan unit.
4. Continue sliding in the fan unit until the front is flush with the back of the VCO/4K enclosure, then tighten the thumb screws located on the left and right sides of the unit. Refer to *Figure 3* for the location of the thumb screws.

NOTE: Do not force the fan unit into the cabinet, the wires may be blocking the installment of the unit. Make certain that the fan power supply wires do not get pinched between the fan unit and the enclosure.

6.0 TROUBLESHOOTING

If the MAJOR and AUX1 alarms are tripped by the AAC, suspect problems with the fan unit. Check the status of the alarm indicator on the fan unit.

Refer to the *VCO/4K Mechanical Assemblies: VCO/4K Power Subsystem* for a guide to LED States.

6.1 Fan Failure

If the Fan Alarm LED on a fan unit illuminates, check the following to identify and correct the problem. These troubleshooting procedures require that the fan unit be removed from the VCO/4K.

Refer to *Section 5.0* for instructions on how to remove the fan unit.

- Check to determine if a foreign object is blocking fan rotation.
- Check that the internal connectors have not become disconnected.
- Make certain that the J5 power connector has not become disconnected.

If the failed fan does not operate, and all troubleshooting details have been checked, remove the fan unit, pack, and ship it to Cisco Systems for service.

CAUTION: Do not operate the VCO/4K until the fan unit has been replaced.

6.2 Power Failure

If a fan unit fails to operate, be sure that power is being provided to the system. Check that the power supply LED is illuminated.

If the power LED is illuminated and the fan unit's front panel LED is extinguished, suspect that no power is being supplied to the fan unit. Remove the fan unit and check that the power plug on the back, left side of the fan unit is plugged in.

If the fan unit still does not operate, contact and report your findings to Cisco Systems Technical Support and request further assistance.

6.3 Fan Failure Problem Fails to be Detected by LED or AAC

If a fan fails to operate and the LED does not illuminate, or an alarm is not sent to the AAC, check the following.

The troubleshooting procedures below require that the fan unit be removed from the VCO/4K. Refer to *Section 5.0* for removal procedures.

If the LED does not illuminate, check that:

- the internal connectors have not become disconnected between the three fan control cards.
- the plug to the LED has not become disconnected.

If an alarm is not sent to the AAC, check that:

- the internal connectors have not become disconnected.

7.0 RELATED DOCUMENTS

For additional information about fan units, refer to the following technical publications:

- *Cisco VCO/4K Hardware Planning Guide*
- *Cisco VCO/4K Hardware Installation Manual*
- *Cisco VCO/4K System Maintenance Manual*
- *Cisco VCO/4K Mechanical Assemblies: VCO/4K Power Subsystem*
- *Cisco VCO/4K Mechanical Assemblies: VCO/4K System Enclosure*

Technical Description

VCO/4K Power Subsystem

1.0 GENERAL DESCRIPTION

The power subsystem in the VCO/4K Open Programmable Switch consists of the following main components:

- Power entry module
- Power backplane
- Power supply module (two modules in redundant systems)

This subsystem is in the lower portion of the VCO/4K system. *Figure 1* shows the front of a redundant system with the door removed and two power supply modules visible. *Figure 2* shows the power entry module in the rear of the system. The power backplane is located internally, between the power supply modules and the power entry module.

The power subsystem powers the following:

- Programmable switch logic
- Disk storage units
- Analog functions
- Ring voltage (if optional ring generator is installed)
- Cooling fans

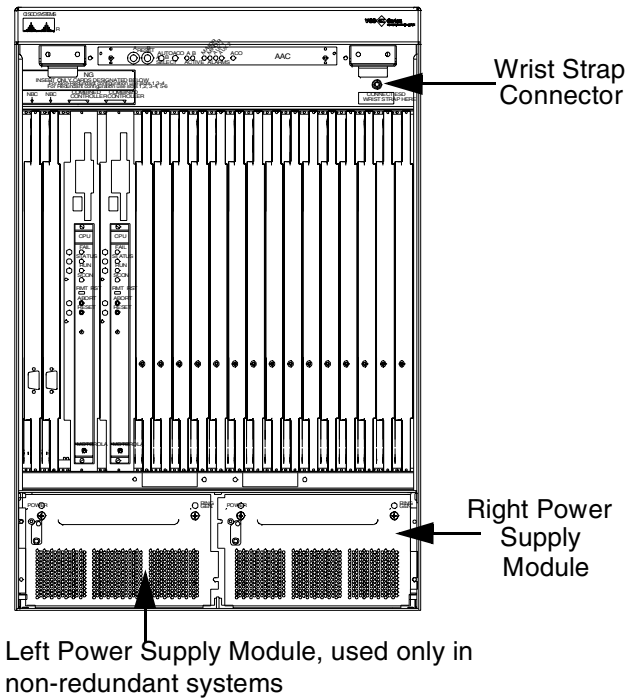

Figure 1: VCO/4K Redundant System (Front View)

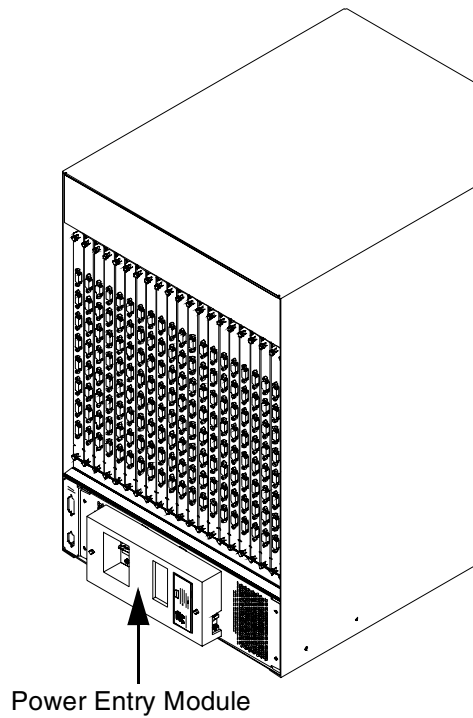

Figure 2: VCO/4K System (Rear View)

2.0 SPECIFICATIONS

The following specifications apply for the three power subsystem components, and the ring generator.

Operating Temperature: 10°C to 40°C (50°F to 104°F)

Relative Humidity: 20% to 80% (non-condensing); temperature rise or fall should not exceed 10°C (18°F) per hour

2.1 Specifications for Power Entry Module

Part Number:	DC:	Contact your Cisco Systems sales representative
	AC:	Contact your Cisco Systems sales representative
	Dual DC Kit:	Contact your Cisco Systems sales representative
Physical Dimensions:	Height:	5 inch (12.5 cm)
	Width:	16 inch (40 cm)
	Depth:	3 inch (7.5 cm)
Nominal Input Voltages:	DC:	-48VDC
	AC:	120VAC or 240VAC

2.2 Specifications for Power Supply Module

Part Number:	AC	Contact your Cisco Systems sales representative
	DC	Contact your Cisco Systems sales representative
Physical Dimensions:	Height:	5 inch (12.5 cm)
	Width:	8 inch (20 cm)
	Depth:	17 inch (42.5 cm)
Output Voltages:	All VDC:	+5, +15, -15, +12, +24, -48

2.3 Specifications for Ring Generator (optional)

Part Number:	Contact your Cisco Systems sales representative	
Physical Dimensions:	Height:	4 inch (10 cm)
	Width:	4 inch (10 cm)
	Depth:	1 inch (2.5 cm)
Output Voltage:	77 VAC	

3.0 POWER ENTRY MODULE

The power entry module (PEM) serves as a mechanical connection point for site power. It includes the following (refer to *Figure 3*):

- Power connector
- Power switch
- Power line filter

The PEM accepts AC or DC source voltages listed in *Table 1*.

*NOTE: The power entry module accepts either a single-line AC feed, a dual-line DC feed, or a single-line DC feed. The factory-installed power supply modules are compatible with the power entry module configuration. The label on the power entry module will either specify your system's type of input power (see *Figure 3*) or list both possibilities (see *Figure 4*). Always verify the input power type by looking at the front of each power supply module. Ensure that the power source is the correct current and voltage for your facility before cabling the power source.*

The line filter ensures that electromagnetic interference (EMI) neither enters nor exits the system.

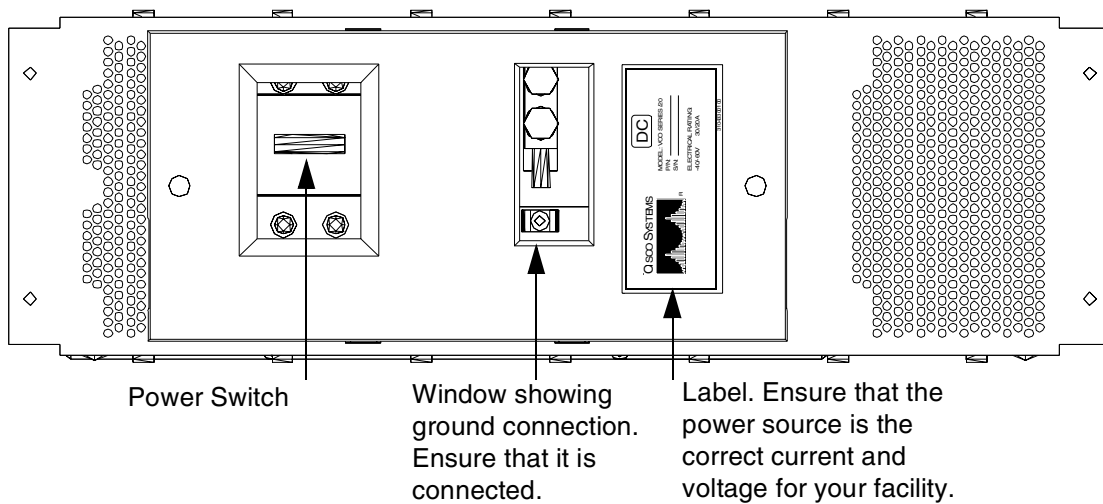

Figure 3: Power Entry Module With Input Power Type Specified

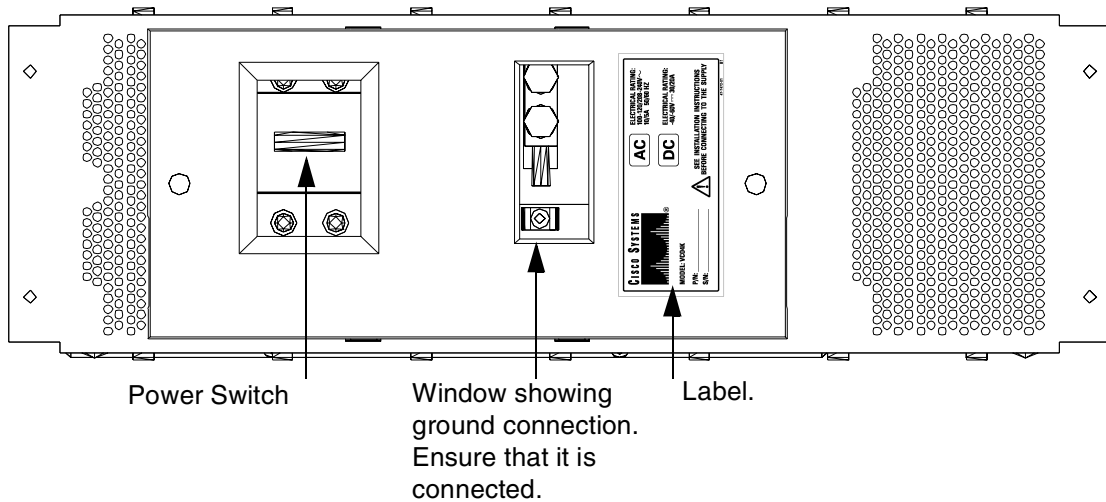

Figure 4: Power Entry Module Without Input Power Type Specified

3.1 Input Power

The VCO/4K can be purchased for AC or DC operation. Your system will come with either AC or DC power supplies, accordingly. *Table 1* lists the power input ratings for AC or DC sources.

Table 1: VCO/4K Power Input Ratings

Nominal	Range	Current	Frequency
-48VDC (per feed)	-40 to -60VDC	20 amps	DC
120VAC, single phase	100 to 120VAC	10 amps	50/60 Hz
240VAC, single phase	208 to 240VAC	5 amps	50/60 Hz

Refer to the *Cisco VCO/4K Hardware Installation Manual* for information on proper wiring of input power. The VCO/4K system is shipped with a kit containing lugs for the input power cabling.

WARNING: Do not open the power entry module (PEM) or you will void your Cisco Systems warranty.

Table 2 indicates the required terminal (labeled TB1 through TB5) for each conductor, for the four possible input power sources. Refer to the *Cisco VCO/4K Hardware Installation Manual* for illustrations.

Table 2: Input Wiring Connections for AC and DC VCO/4K Systems

Conductor	Terminal
Single Feed –48VDC (nominal)	
Jumper 1	TB1 to TB4
Jumper 2	TB2 to TB5
Battery return (+)	TB4
Battery (-)	TB5
Ground	TB3
Dual Feed –48VDC (nominal)	
Battery Return A(+)	TB1
Battery A(-)	TB2
Battery Return B (+)	TB4
Battery B (-)	TB5
Ground	TB3
Single Feed 120VAC (nominal)	
Neutral	TB5
Line	TB2
Ground	TB3
Single Feed 240VAC (nominal)	
Line 1	TB2
Line 2	TB5
Ground	TB3

3.2 Indicator LEDs

There are two LEDs on the front of the power supply module; the power LED on the left side, and the Ring Generator LED on the right side. Refer to *Figure 5*.

Power LED

The power LED is on the upper left side of the power supply module. When illuminated, it is either green or red.

- Green indicates that the power is on and operation is normal.
- Red indicates a voltage failure although the interlock switch is closed and the power is on.

Replace either the fuse or the power supply module. Refer to *Section 7.2* for information on the fuse, and *Section 6.1* and *Section 6.2* for power supply module removal and replacement steps.

- Red could also indicate that you failed to install the external jumper needed for single-line feed DC operation (refer to *Table 2*).
- When the LED is off, or if it glows a faint red (reduced illumination), the interlock switch is open (power to the module is turned off).

Ring Generator LED

The Ring Generator LED is on the upper right side of the power supply module. When illuminated, it is either green or red.

- Green indicates that a ring generator is installed and working correctly.
- Red indicates a ring generator failure.
- When the LED is off, there is no ring generator present in that power supply module.

3.3 Interlock Switch

The interlock switch is under the power LED. Use this switch to remove and replace power supply modules while the system is running. To safely remove the power supply module, turn off the output power (switch in the open position). Remove the upper left screw to open the interlock switch. Refer to *Figure 5*. Refer to *Section 6.1* for instructions on removing a redundant power supply module.

When you close the interlock switch, the output power is turned on, and the power supply module is operational.

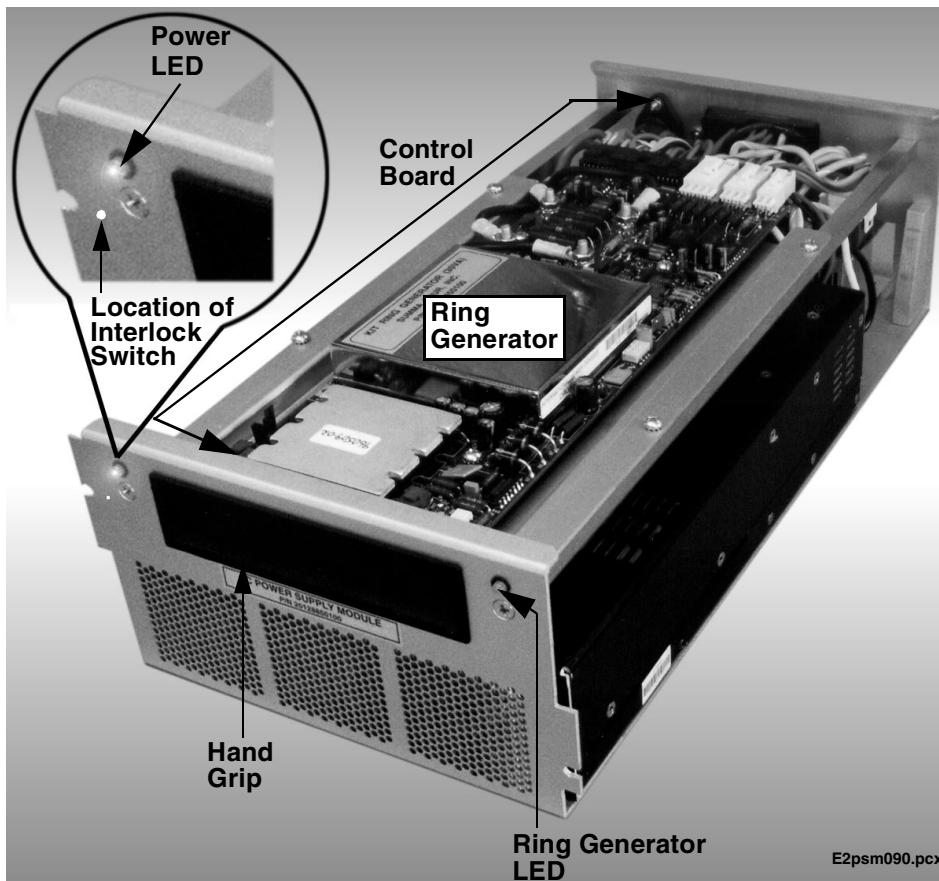

Figure 5: Power Supply Module

4.0 INPUT AND OUTPUT POWER DISTRIBUTION

Input power from the power entry module travels through the power backplane to the power supply module where it is converted to usable voltages. The power supply module distributes the voltages to the power backplane, which distributes it to the rest of the system.

The power backplane contains:

- four fuses (can be automatically reset)
- connections for alarm signals
- internal equipment safety connection

Figure 6 is a system-level functional diagram of the power subsystem.

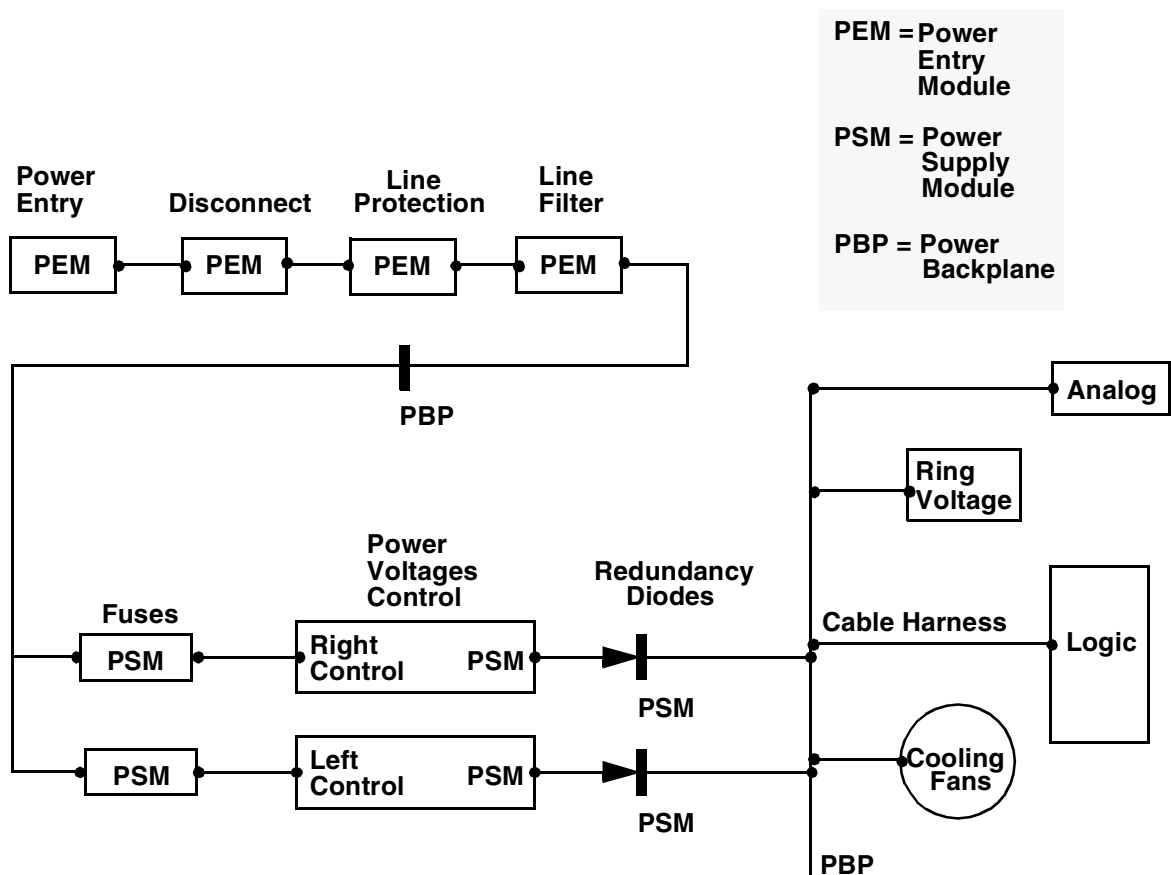

Figure 6: Power Subsystem Functional Diagram for Single-Feed AC/DC Operation

NOTE: If you want single DC input power, you must install two external jumpers: a/rtn to b/rtn and a/bat to b/bat. This way, both power supply modules are powered from a common feed.

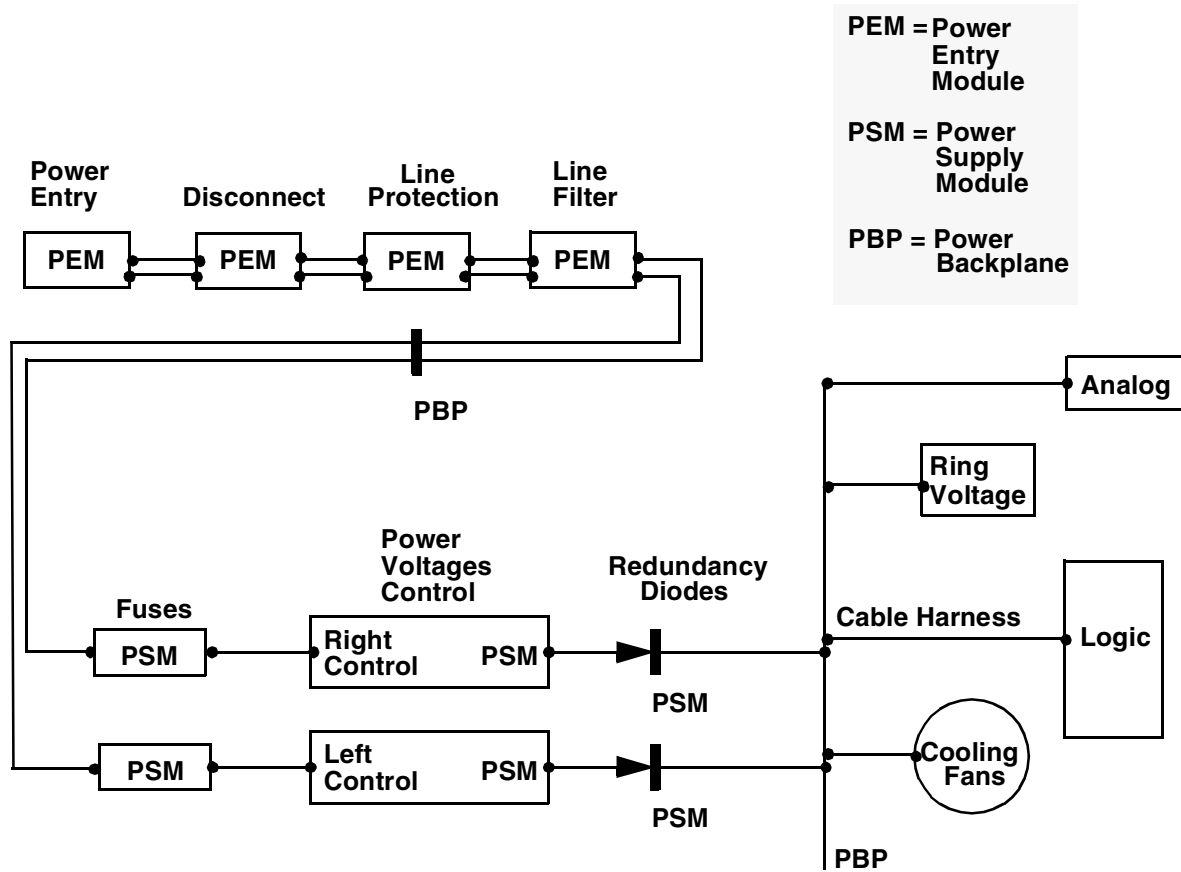

Figure 7: Power Subsystem Functional Diagram for Dual-Feed DC Operation

4.1 Output Power Redundancy and Load Sharing

The main power supply module is on the left of all VCO/4K systems. In nonredundant systems, ensure that the power supply module is on the left.

The following describes the power supply load-sharing and redundancy in VCO/4K systems:

- The modules share the total load on each voltage in redundant systems.
- The system automatically remains in operation without interruption, during and after a power supply module failure. The system disconnects the failed module and switches all power to the redundant module.
- The power supply modules provide individual load-sharing for each voltage. If a voltage failure occurs, it continues to load-share the remaining voltages.

For example, if the +5VDC voltage fails in a power supply module, the remaining voltages are not affected, and continue to load-share with the other module.

- Each module is equipped with a 25-amp fuse, ensuring that redundancy is maintained in the event of an overcurrent fault. If a fuse blows in one power supply module, the system does not shut down.

The power supply module provides six regulated DC voltages for system operation, as shown in *Table 3*.

Table 3: Power Supply Module Output Voltages

Voltage	Tolerance	Current
+5VDC	±0.25V	84 amps
+15VDC	±0.5V	4 amps
-15VDC	±0.5V	4 amps
+12VDC	+3V, -0V	1 amp
+24VDC	±1.0V	1 amp
-48VDC	±4.0V	3 amps

5.0 RING GENERATOR

The ring generator is active only when it is installed in the left power supply module. Ring generators can be installed in both power supply modules in a redundant system. However, the ring generator in the right power supply module is not connected to the system and is considered a spare. Power loss to the left power supply module results in loss of the ring generator (if installed).

The two circuit configuration jumpers, JP6 and JP7, on the power supply module, are configured as shown in *Table 4* when the VCO is shipped with a ring generator installed. This configuration is required for proper operation of the ring generator alarm and its LED. Refer to *Section 3.2* for information about the LED.

If your system has a ring generator, you must install JP7, in the left module only.

Table 4: JP6 and JP7 Configuration

Configuration	JP6	JP7
Right Power Supply Module	Install when ring generator is present	Remove
Left Power Supply Module without a ring generator	Remove	Remove
Left Power Supply Module with a ring generator	Install	Install

Note: If you install a ring generator, configure the JP6 and JP7 jumpers. The ring generator kit includes installation instructions.

6.0 REMOVAL AND REPLACEMENT PROCEDURES

Follow ESD rules when removing or replacing a system component. Use a wrist strap connected to the system for grounding. Refer to *Figure 1*.

WARNING: Voltages present on the power backplane and at other test points produce severe, perhaps fatal electrical shock. Observe all precautions normally associated with the testing of electrical equipment.

Turn off power at the source before performing any service.

6.1 To Remove a Power Supply Module

Note: Follow ESD rules when removing a system component. Use a wrist strap for grounding.

To remove a nonredundant power supply module:

1. Turn the switch off on the power entry module if the system does not contain redundant power supply modules, or if both power supply modules are to be removed simultaneously. The power disconnect switch is located in the rear of the system on the power entry module (see *Figure 3*).
2. Remove the front door of the VCO/4K system to access the power supply module.
3. Connect your wrist strap to the system (upper right corner). Refer to *Figure 1*.
4. Remove the two mounting screws on the front panel of the power supply module. When the upper left screw is removed, the power is cut off from the module (the power LED is off).

Note: If the LED is faintly illuminated red, and the interlock switch screw is removed, it is safe to remove the power module.

5. Grasp the black hand grip on the front of the module with one hand and pull the module out. Use your other hand to provide support underneath the module as you remove it from the system.

To remove a redundant power supply module:

1. Remove the front door of the VCO/4K system to access the power supply module.
2. Connect your wrist strap to the system (upper right corner). Refer to *Figure 1*.
3. Remove the two mounting screws on the front panel of the power supply module.
When the upper left screw is removed, the power is cut off from the module (the power LED is off).

Note: If the LED is faintly illuminated red, and the interlock switch screw is removed, it is safe to remove the power module.

4. Grasp the black hand grip on the front of the module with one hand and pull the module out. Use your other hand to provide support underneath the module as you remove it from the system.

6.2 To Replace a Power Supply Module

Note: Follow ESD rules when removing a system component. Use a wrist strap for grounding.

1. If the power supply module is nonredundant, ensure that the power is off.
2. Remove the front door of the VCO/4K system to access the power supply module.
3. Connect your wrist strap to the system (upper right corner). Refer to *Figure 1*.
4. Grasp the black hand grip on the front of the module with one hand and use your other hand to provide support underneath the module as you push it into its compartment.
5. Fasten the two mounting screws on the front panel of the power supply module.
Ensure that you rotate the plate into position to align the left mounting screw before fastening the screw into place.
6. If necessary, turn the VCO/4K system on.
7. Remove your wrist strap.
8. Check the power LED and ensure that the power supply module is operating. Refer to *Section 3.2* for information on the LED.
9. Replace the front door. **The front door must remain on during system operation for EMI compliance.**

7.0 TROUBLESHOOTING

7.1 Alarms

The following two events occur simultaneously when voltage monitoring on the control board of the power supply module detects either an over-voltage or an under-voltage condition:

- An alarm is sent to the Alarm Arbiter card (AAC) and is displayed on the AAC—the red MAJOR LED turns on; the yellow AUX1 LED turns on.
- The power LED on the power supply module turns red.

When these two events occur, you must replace the power supply module. Refer to *Section 6.1* and *Section 6.2*.

7.2 Spare Fuse Kit

One spare fuse kit containing two 25-amp fuses comes with the VCO/4K. A fuse is on the back of each power supply module.

8.0 RELATED DOCUMENTS

For additional information on the VCO/4K power subsystem, refer to the following publications:

- *Cisco VCO/4K Site Preparation Guide*
- *Cisco VCO/4K Hardware Installation Manual*
- *Cisco VCO/4K System Maintenance Manual*
- *Ring Generator Instruction Sheet* (included with the ring generator kit)

Related Documents

Technical Description

Storage/Control I/O Module

1.0 GENERAL

The Storage/Control I/O Module performs two functions: to connect outside interfaces to the system controller and to house the hard disk drive. It plugs into the back of the VCO/4K system and provides the I/O interfaces for system peripheral devices and host communication links using four serial ports, one Ethernet port, one printer port and one SCSI connector. *Figure 1* is an illustration of the front panel of the Storage/Control I/O Module.

Physical interfaces to host computers and peripheral devices are provided on the front panel of the Storage/Control I/O Module. Two serial ports are available for SIO host links, and another two are dedicated to supporting the local system administration console and a remote maintenance modem. An Ethernet Transceiver interface and parallel printer connector are also located on the Storage/Control I/O Module.

2.0 SPECIFICATIONS

Part Number: Contact your Cisco Systems sales representative

Interfaces: Four EIA/TIA-232 serial ports (master console, remote maintenance modem, and two SIO host links)
One Ethernet transceiver interface
One Centronics-type parallel interface (system printer)
One SCSI connector (reserved for future use)

Power Requirements:		Maximum	Typical
Hard Disk Drive	+5Vdc	0.4A	0.33A
	+12Vdc	1.0A	0.17A
Ethernet	+5Vdc	0.5A	0.5A
	+12Vdc	0A	0A
RS232	+5Vdc	0A	0A
	+12Vdc	0.1A	0.05A
Total Current	+5Vdc	0.9A	0.85A
	+12Vdc	1.1A	0.22A
Total Power	+5Vdc	17.7 Watts	
	+12Vdc	6.89 Watts	

Operating Temperature: 10°C to 40°C (50°F to 104°F)

Relative Humidity: 20% to 80% (non-condensing)

Physical Dimensions: Height: 14.4 inch
Depth: 5.6 inch
Width: 1.6 inch

3.0 DESCRIPTION

The Storage I/O Module is two card slots wide and slides into the back of the VCO system where it plugs into the control midplane. All outside connections are mounted on the faceplate of the module. All internal connectors are mounted on the board itself for easy access to system internals (for example, SCSI and Ethernet).

The VCO/4K system hard drive is mounted on the upper portion of the I/O Module. The board is built to accommodate a 3.5 inch hard drive. Physical mounting points are provided for the hard drive as well as a 50-pin SCSI interface to the system controller. There is also a provision for an external SCSI connection on the front panel. The SCSI connection is reserved for future use.

3.1 Front Panel Indicators and Ports Assignments

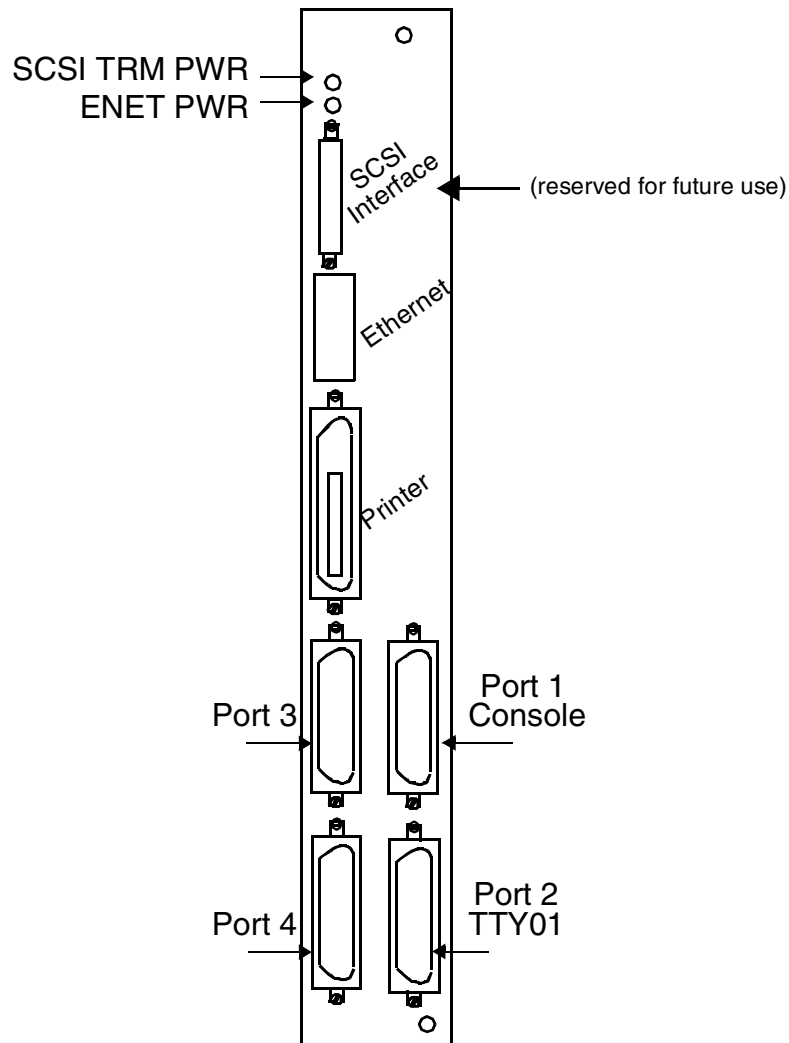

Figure 1: Storage/Control I/O Module Front Panel

Power is supplied to the Storage/Control I/O Module via the midplane from the combined controller card. The hard drive LED signal is brought to the system controller board via the midplane and brought out to the front panel to show hard drive activity. It is located on the combined controller in the front of the VCO. Refer to *Figure 3*.

SCSI terminations are provided as an option to be populated on the Storage/Control I/O Module depending on the system configuration. They are currently not being used.

The connectors mounted on the front panel:

4 serial ports	DB-25
SCSI port	50-Pin mini-SCSI connector
Ethernet	DB-15
Printer	36-Pin Centronics

The connectors mounted on the board:

SCSI	DIN 64
MODEM	20-Pin IDC connector
MODEM power	5-Pin header

The LEDs mounted on the board:

ENET	If illuminated, shows that power is available to the ethernet
SCSI	If illuminated, shows that there is SCSI termination power

3.2 Hard Disk Drive

The hard disk drive is a SCSI-compatible drive that is used as the system controller's main data storage facility. The hard disk drive requires +5 volts and +12 volts DC to operate. The Storage/Control I/O Module supports the hard disk drive LED. The LED is located on the combined controller and is visible from the front of the system, refer to *Figure 3*.

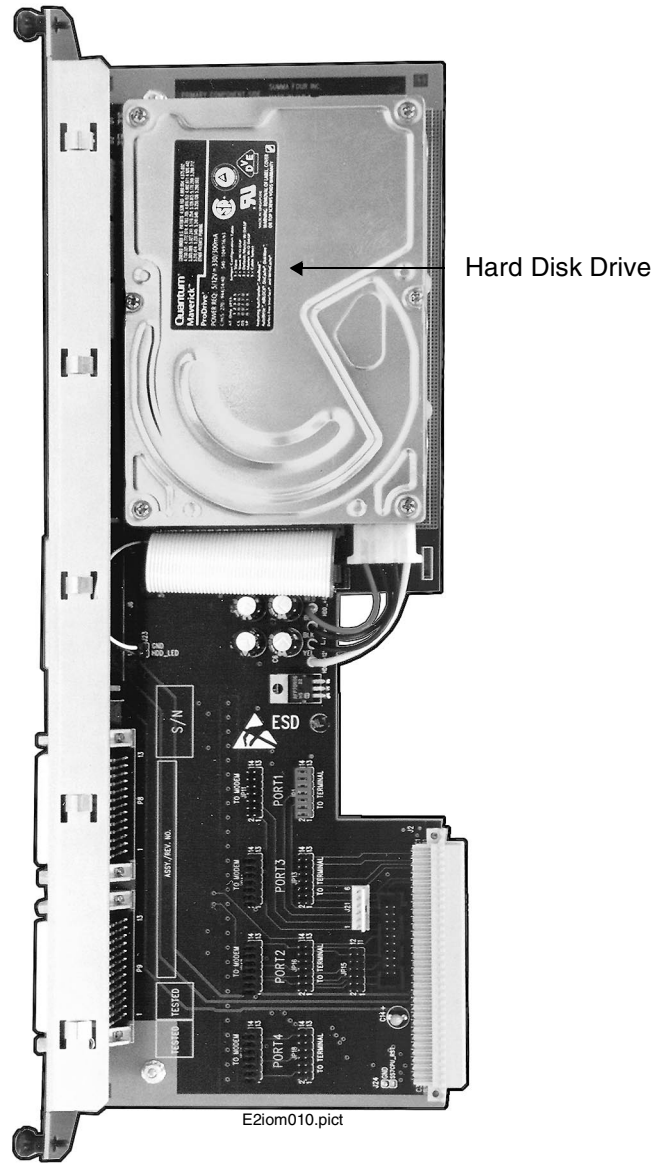

Figure 2: Location of the Hard Disk Drive on the Storage/Control I/O Module

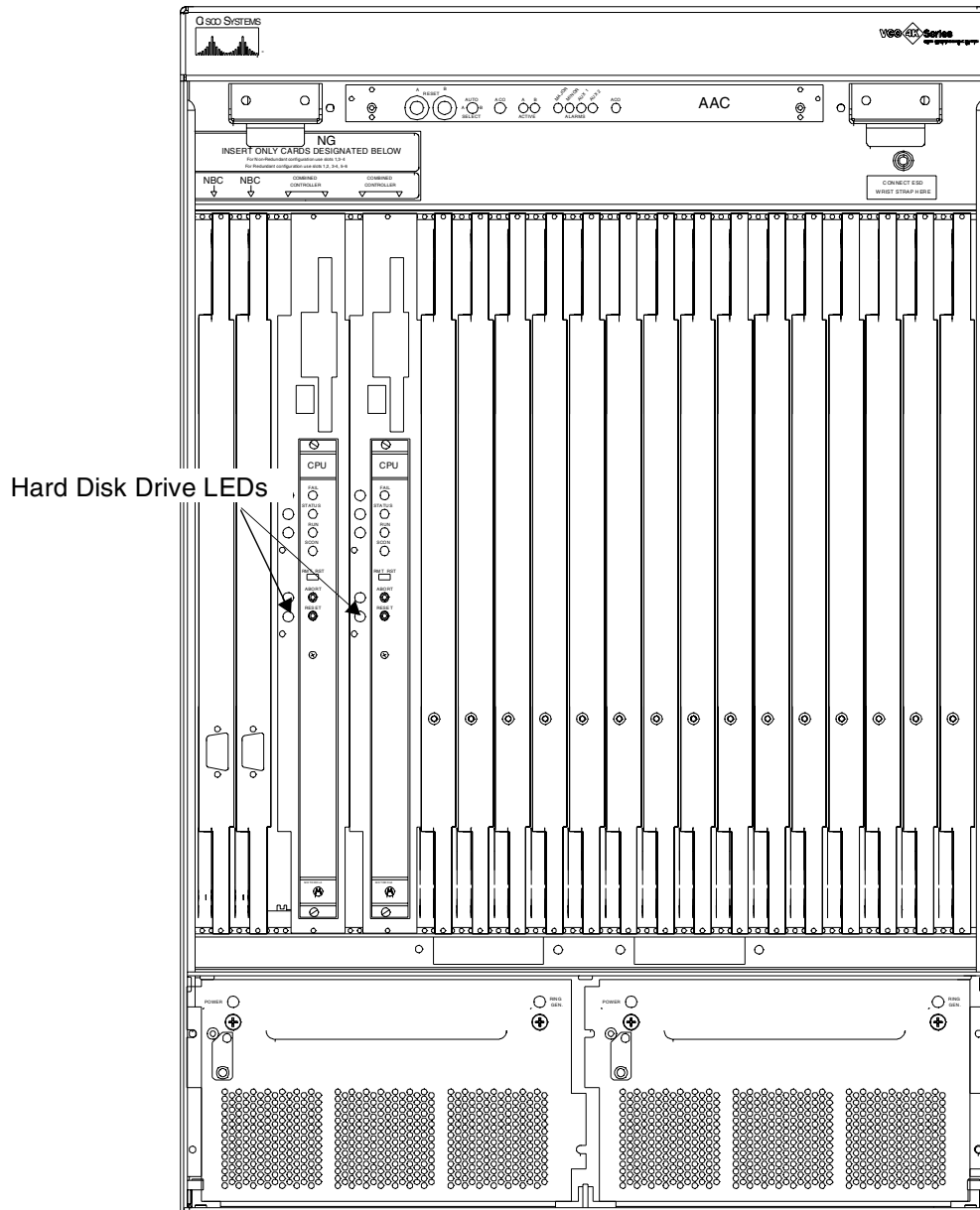

Figure 3: Location of Hard Disk Drive LED on the Combined Controller

3.3 Midplane Connectors

The Storage/Control I/O Module plugs into the midplane through standard DIN 41612 triple-row, 96-pin male connectors.

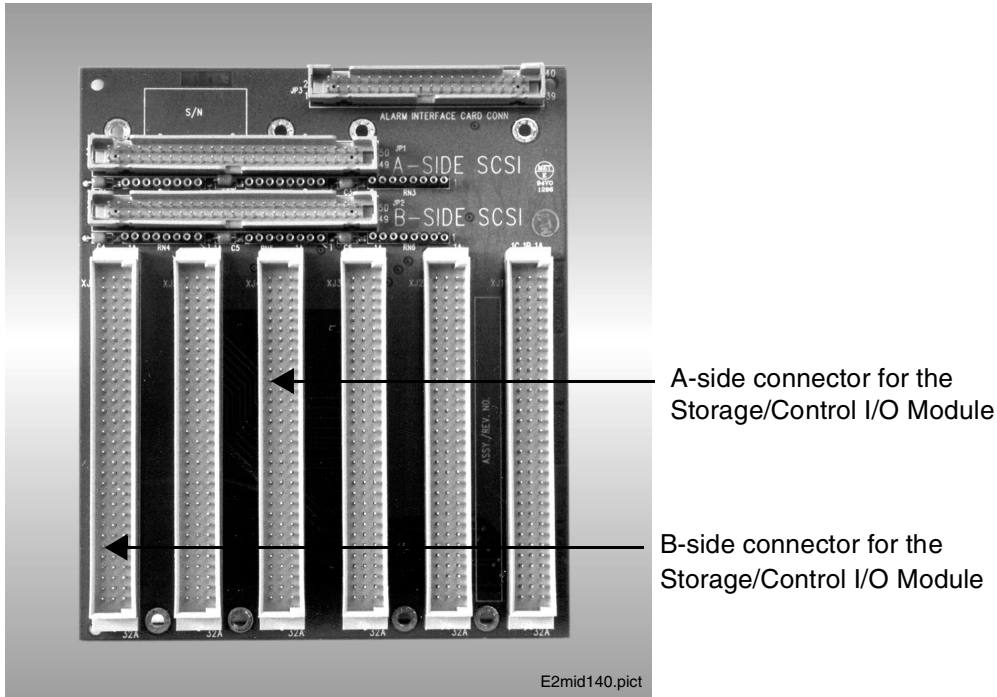

Figure 4: The Control Midplane

3.4 Serial Ports 1 and 2

Serial Port 1/Console and Serial Port 2/TTY01 are dedicated ports for connecting the system master console and remote maintenance modem, respectively. These standard female DB-25 ports connect to the console and modem via EIA/TIA-232 cables. *Table 1* shows the pin and signal assignments for these ports. For additional information on connecting peripheral equipment, refer to the *Cisco VCO/4K Hardware Installation Manual*.

Table 1: Serial Ports 1, 2 and 3 Pin and Signal Assignments^a

Pin	Signal Name	Description/Direction
2	TxD	Transmit Data (terminal to modem)
3	RxD	Receive Data (modem to terminal)
4	RTS	Request to Send (terminal to modem)
5	CTS	Clear to Send (modem to terminal)
6	DSR	Data Set Ready (modem to terminal)
7	GND	Chassis Ground
8	DCD	Data Carrier Detect (modem to terminal)
20	DTR	Data Terminal Ready (terminal to modem)

^aAll pins not identified are no-connection

Master console and remote maintenance modem operating parameters (Baud Rate, Stop Bits, Bits per Character and Parity) defined in the system database via the Peripheral Configuration screen. Refer to the *Cisco VCO/4K System Administrator's Guide* for more information.

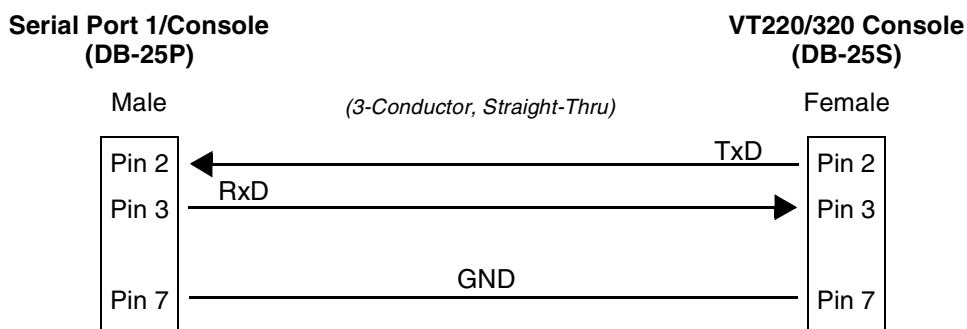

Figure 5: I/O Module To Master Console – Cable Wiring Diagram

NOTE: You can employ a 25-conductor, straight-thru cable to connect a master console to the Storage/Control I/O Module; however, only the conductors shown above are used.

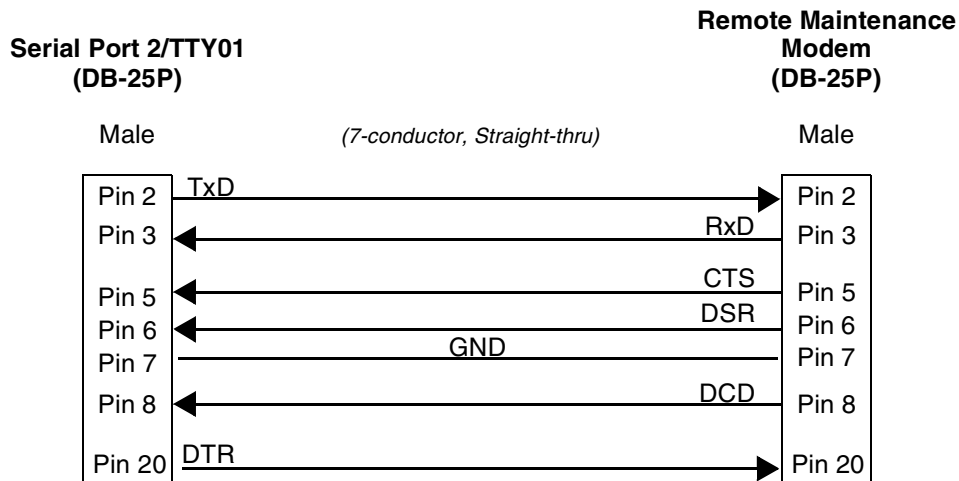

Figure 6: I/O Module To Remote Maintenance Modem – Cable Wiring Diagram

NOTE: You must use a 9-pin connector (available from Cisco Systems). A 25-pin connector can be used after the switch box.

3.5 Serial Ports 3 and 4

Serial Ports 3 and 4 are available for Serial I/O (SIO) links between the system and a host computer. These standard female DB-25 ports carry Asynchronous Data Link Control (ADLC) protocol signals between the host and the system over RS-232C cables. Pin and signal assignments for port 3 is the same as Serial Ports 1 and 2. Refer to *Table 2* for port 4 pin and signal assignments.

Wiring conventions for physically connecting a host computer to a SIO port are provided in the *Cisco VCO/4K Hardware Installation Manual*. Jumpers on the Storage/Control I/O Module allow Serial Ports 3 and 4 to be configured as modem (DCE) terminations for connection to a terminal or configured as terminal (DTE) terminations for connection to a modem. Refer to *Serial Ports 1 through 4 and Jumper Settings* on page 1-12 for more information on jumper configurations.

Data communication parameters for each host link must be defined in the system data base using the Host Configuration screen following system power-on. Refer to the *Cisco VCO/4K System Administrator's Guide* for instructions on defining host links. Additional information on the ADLC protocol supported by serial host connections is contained in the *Cisco VCO/4K Host Communications Guide*.

Table 2: Serial Port 4 Pin and Signal Assignments^a

Pin	Signal Name	Description/Direction
2	TxD	Transmit Data (terminal to modem)
3	RxD	Receive Data (modem to terminal)
4	RTS	Request to Send (terminal to modem)
5	CTS	Clear to Send (modem to terminal)
6	DSR	Data Set Ready (modem to terminal)
7	GND	Chassis Ground
8	DCD	Data Carrier Detect (modem to terminal)
15	RTxC	Tx Clock to output data (terminal to modem)
17	RRxC	Rx Clock to input data (terminal to modem)
20	DTR	Data Terminal Ready (terminal to modem)
24	TTxC	Tx Clock to output data (terminal to modem)

^aAll pins not identified are no-connection

3.6 Ethernet Interface

The CPU employs a Local Area Network Controller for Ethernet (LANCE) to implement an Ethernet transceiver interface. The balanced transceiver signal lines from the CPU are coupled to an onboard transformer to signal lines that go through the SWI, Outer B/P and control midplane cards, and terminate on the industry-standard DB-15 connector on the Storage/Control I/O Module faceplate. Pin and signal assignments for this DB-15 port are listed in *Table 3*.

Table 3: Ethernet Port Pin and Signal Assignments

Pin	Signal	Signal Name
2	C+	Collision + (Input)
3	T+	Transmit + (Output)
5	R+	Receive + (Input)
6	GND	Ground
9	C-	Collision - (Input)
10	T-	Transmit - (Output)
12	R-	Receive - (Input)
13	+12V	+12 Vdc Power

To implement Ethernet links, you must purchase the optional Ethernet Communications Package available from Cisco Systems. This package contains supporting software and the *Cisco VCO/4K Ethernet Guide* which covers the cabling requirements and implementation strategies. You must provide cables, transceivers and other components to establish Ethernet links.

3.7 Printer Interface

The printer interface on the Storage/Control I/O Module front panel supports parallel system printers through a 36-pin Centronics-type connector. *Figure 7* shows the cable wiring diagrams for connecting the Storage/Control I/O Module parallel port to the system printer.

NOTE: The End of Line (EOL) terminator for the system printer must be defined in the system data base via the Peripheral Configuration screen prior to use (refer to the Cisco VCO/4K System Administrator's Guide for more information).

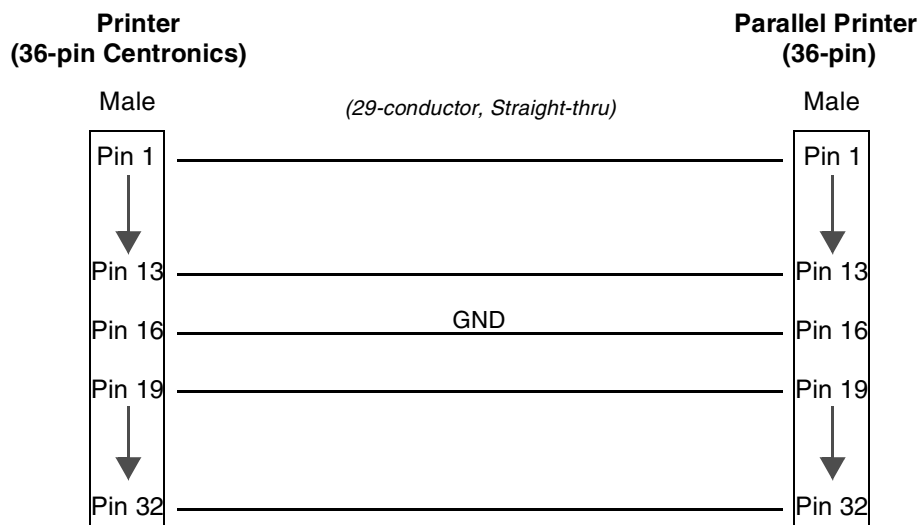

Figure 7: I/O Module To System Printer – Cable Wiring Diagram

NOTE: You can employ a 36-conductor, straight-thru parallel cable to connect a printer to the system controller; however, only the conductors shown above are used. For more information on the parallel 36-pin Centronics cable available from Cisco Systems, refer to the Cisco VCO/4K Hardware Planning Guide.

3.8 SCSI Interface

The SCSI mass storage bus interface on the Storage/Control I/O Module is not used in system operation.

4.0 HARDWARE CONFIGURATION

This section outlines hardware configuration options.

4.1 SCSI Termination Configuration

The SCSI Interface connector is reserved for future use.

4.2 Serial Port Configuration

Serial Ports 1 through 4 and Jumper Settings

Serial ports 1 through 4 on the Storage/Control I/O Module can be configured as modem (DCE) terminations for connection to a terminal or configured as terminal (DTE) terminations for connection to a modem. (Refer to *Serial Ports 1 through 4* for more information.)

Jumpers are positioned in J1 for Serial Port 1 (master console), JP17 for Serial Port 2 (remote maintenance modem, and JP13 and JP18 for Serial Ports 3 and 4 (SIO host links), respectively.

For Serial Ports 1 and 2, these jumper settings assume that straight-thru EIA (DCE to DTE) cables are used to connect the system to the master console and remote maintenance modem. If the jumpers are moved to position JP11 (for the master console) and JP16 (for the remote modem), crossover cables can be used.

NOTE: Straight-through cables directly link the connector pinouts from end-to-end. In crossover cables, Pins 2 and 3 are crosswired; Pin 2 at one end is wired to Pin 3 at the opposite end, and vice versa.

Jumper settings for Serial Ports 3 and 4 (SIO host links) are determined by two factors: the type of cable employed (straight-thru or crossover) and the host termination at the end of the cable (terminal or modem).

The default jumper settings for Serial Ports 3 and 4 configure the CPU as a DTE termination. This configuration supports the following arrangements:

- Straight-thru cables connecting the system to a modem (DTE to DCE)
– *or* –
- Crossover (null modem) cables connecting the system to a terminal (DTE to DTE)

You can position the jumpers in locations JP13 and JP18 (under the “To Terminal” etching) to configure the CPU as a DCE termination. Moving the jumpers to these locations supports the following SIO connections:

- Straight-thru cables connecting the system to a host terminal (DCE to DTE)
- or –
- Crossover (null modem) cables connecting the system to a modem (DCE to DCE)

Refer to the *Cisco VCO/4K Hardware Installation Manual* for more information on serial cable requirements.

NOTE: When modifying jumper positions on Storage/Control I/O Module boards, all 7 jumpers must be moved to the new location to insure operation.

Serial Ports 1 through 4

Serial ports 1 through 4 can be configured as a modem (DCE) for connection to a terminal, or terminal (DTE) for connection to a modem. The Storage/Control I/O Module card's serial ports are configured for shipment in the DCE configuration. The following table illustrates jumper positions for DCE and DTE.

Port	DTE Operation	DCE Operation
1	Jumper – TO MODEM JP11	Jumper – JP1 TO TERMINAL
2	Jumper – TO MODEM JP17	Jumper – JP16 TO TERMINAL
3	Jumper – TO MODEM JP14	Jumper – JP13 TO TERMINAL
4	Jumper – TO MODEM JP19	Jumper – JP18 TO TERMINAL

Refer to *Figure 8* for the jumper locations on the Storage/Control I/O Module card.

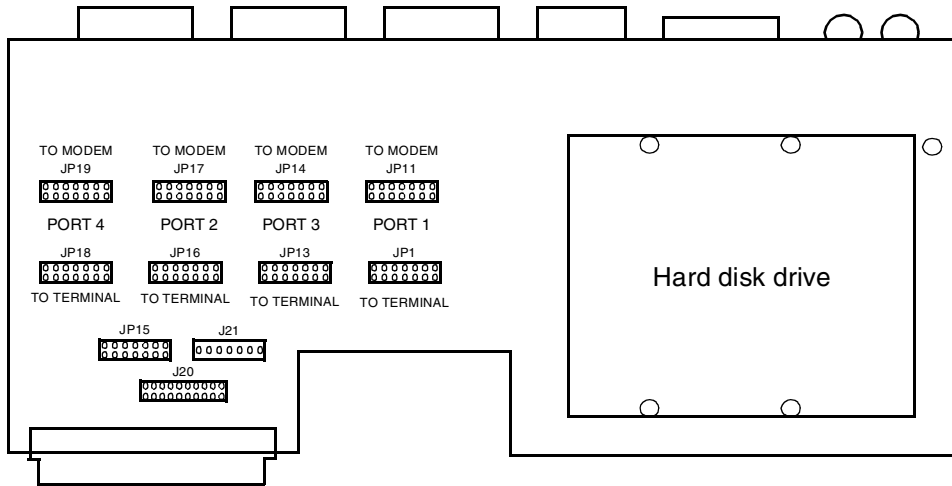

Figure 8: Jumper Locations

Seven jumpers are installed at jumper locations JP1, JP11, JP13, JP14, JP16, JP17, JP18 and JP19, connecting pins 1-2, 3-4, 5-6, 7-8, 9-10, 11-12, 13-14 as shown in *Figure 9*.

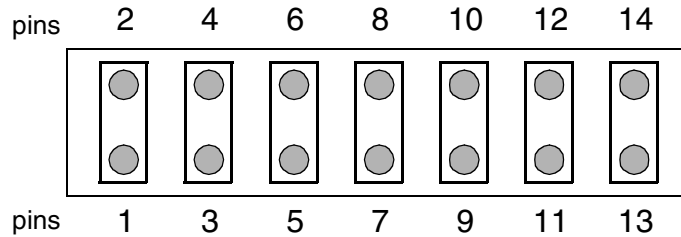

Figure 9: Jumper Configuration for DCE/DTE, Serial Ports 1-4

Serial port 4 can be configured to use clock signals by the TRXC4 and RTXC4 signal lines. Jumper JP15 configurations of the clock lines are shown in *Figure 10*. The module is shipped without clock lines connected.

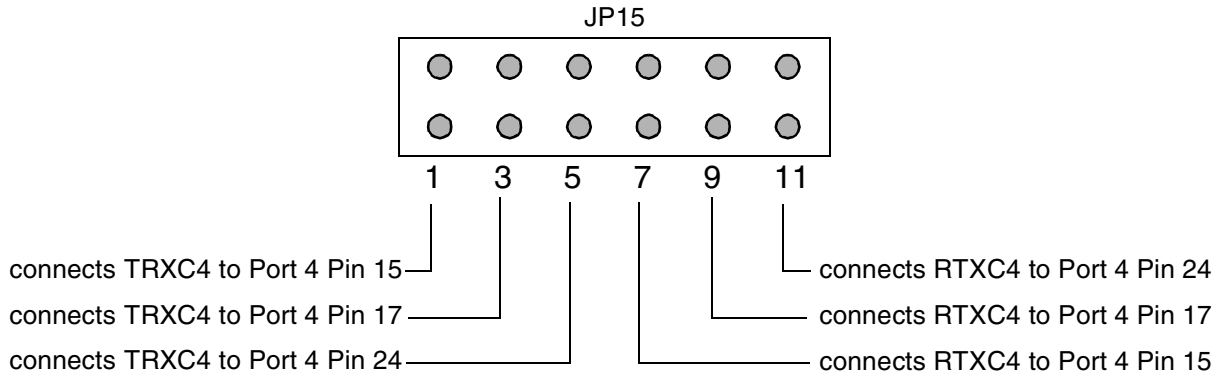
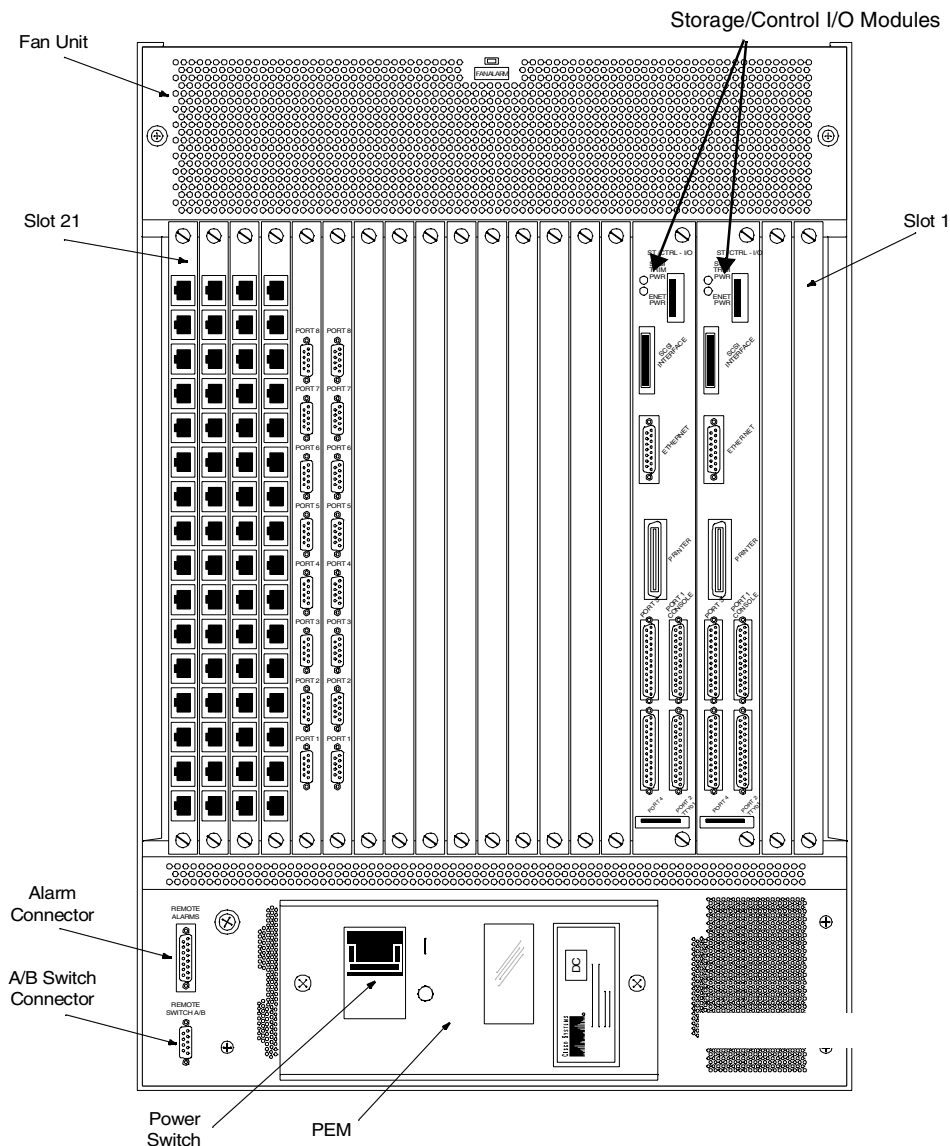

Figure 10: Jumper 15 Configuration of Clock Lines, Serial Port 4

5.0 REMOVAL/REPLACEMENT INFORMATION

Figure 11 shows the location of the Storage/Control I/O Module cards in the rear of the VCO system. The card is located in slots 3 to 4 in nonredundant systems, and in slots 3 to 4 and 5 to 6 in redundant systems. The label at the base of the card cage identifies where the card(s) is located. Refer to Figure 11.

There is a soft start circuit on the card which allows for the Storage/Control I/O Module to be removed and replaced while the system is running. This should only be done when the system contains redundant Storage/Control I/O Modules, and when the module to be removed is in standby mode.



E2bck030.pict

Figure 11: Storage/Control I/O Module Location

Nonredundant Systems

When removing and replacing a Storage/Control I/O Module card in a nonredundant system, the system must be powered down. The system is out of service until the card is replaced.

Redundant Systems

To remove and replace a Storage/Control I/O Module card in a redundant system:

1. If servicing an active Storage/Control I/O Module, switch the active side to standby. Refer to the *Cisco VCO/4K System Administrator's Guide, Maintenance* section for information about how to switch the active side to standby.
2. When the transition to standby is complete, the Storage/Control I/O Module can be removed and replaced.

5.1 Removal Procedures

If permanently removing the Storage/Control I/O Module from a nonredundant system, back-up the database before powering-down the system and removing the module. Refer to the *Cisco VCO/4K System Administrator's Guide* for information on backing-up the database.

To remove a Storage/Control I/O Module:

CAUTION: If removing the Storage/Control I/O Module from a nonredundant system, power down the system before removing the card.

1. Make certain you are properly ESD grounded. Use a wrist strap, attached to the ground connector located in the front, inside of the VCO. The ground connector can be identified by the label: CONNECT ESD WRIST STRAP HERE
2. Remove the Combined Controller that is connected to the Storage/Control I/O Module to be serviced. Refer to the *Cisco VCO/4K Card Technical Description Series: Combined Controller Assembly* for information on how to remove the Combined Controller.

If removing the Combined Controller from a redundant system, make certain that it is in standby mode. (Refer to *Redundant Systems, step 1* above.)

3. Use a 1/8-inch bladed screwdriver to loosen the captive mounting screws at the top and bottom of card. Do not remove the screws from the cards.
4. Grasp the screws at the top and bottom of the card and pull the card away from the midplane.

The card fits tightly into the midplane connectors and some force is required to pull it away from the midplane. However, do not exert excessive force on the card to remove it.

5. When the card is free of the connector, grasp the sides of the front panel and pull the card free of the card slot.
6. Grasp the card on its bottom edge as it is removed from the subrack.
7. When the card has been removed from the subrack card slot it should be placed on an antistatic mat or an antistatic envelope.

NOTE: Do not replace the Combined Controller until the Storage/Control I/O Module is replaced. If the Storage/Control I/O Module is not replaced at the time of removal, do not replace the Combined Controller.

5.2 Replacement Procedures

To replace the Storage/Control I/O Module:

1. Make certain you are properly ESD grounded. Use a wrist strap, attached to the ground connector located in the front, inside of the VCO. The ground connector can be identified by the label: CONNECT ESD WRIST STRAP HERE
2. Place the replacement Storage/Control I/O Module on the antistatic mat or envelope.
3. Verify that the Combined Controller that is to be connected to the Storage/Control I/O Module is *not* plugged into the backplane.
4. Verify that all the jumpers on the replacement card correspond with those on the removed Storage/Control I/O Module.

Verify that the jumper configuration is appropriate for the system configuration.

Refer to *Serial Ports 1 through 4 and Jumper Settings* for details on jumper settings for the Storage/Control I/O Module.

5. Grasp the replacement card by the sides of the front panel and align it with the top and bottom card guides of the subrack.
6. Push the card inward until it makes contact with the midplane.
7. Firmly push the card toward the midplane. The card fits tightly into the midplane connectors and some force is required to seat the card back firmly into the midplane connectors.
8. Use a 1/8-inch bladed screwdriver to tighten the mounting screws at the top and bottom of each card into the tapped holes on the mounting rail.
9. Plug the Combined Controller into the backplane.
10. If installing in a nonredundant system, make sure the system is powered on.
11. If the hard disk drive does not contain the Generic software, install the software. Refer to the system release notes for instructions on installing the Generic software, backing up and restoring the database, and licensing.

6.0 TROUBLESHOOTING

LEDs Not Illuminated

If either of the LEDs on the Storage/Control I/O Module is not illuminated, corrective action should be taken. These LEDs are fused powered sources. The fuses are on the Combined Controller and are not field replaceable. Call Cisco Systems for technical support.

NOTE: The ENET PWR LED should be illuminated only when Ethernet is being used. If the ENET PWR LED is not illuminated and ethernet is being used, contact Cisco Systems Technical Support.

Troubleshooting Reference Materials

The *Cisco VCO/4K System Maintenance Manual* describes corrective maintenance procedures for host communications links. In addition to this manual, refer to the *Cisco VCO/4K Host Communications Guide* and the *Cisco VCO/4K Standard Programming Reference* and *Cisco VCO/4K Extended Programming Reference* for details relating to communication protocols and command/report formats. The *Cisco VCO/4K System Messages* describe the network messages associated with problems detected with the host communications links.

If you are employing the optional Ethernet Communications Package, refer to the *Cisco VCO/4K Ethernet Guide* for maintenance procedures.

Additional reference materials include the OEM manuals provided with any other peripheral devices connected to the Storage/Control I/O Module. This includes the printer and the serial terminal.

7.0 RELATED DOCUMENTS

For additional information regarding the operation, application, installation and maintenance of the CPU refer to the following system publications:

- *Cisco VCO/4K Product Overview*
- *Cisco VCO/4K Hardware Planning Guide*
- *Cisco VCO/4K Installation Manual*
- *Cisco VCO/4K System Maintenance Manual*
- *Cisco VCO/4K Mechanical Assemblies: System Enclosure*
- *Cisco VCO/4K Host Communications Guide*
- *Cisco VCO/4K Standard Programming Reference*
- *Cisco VCO/4K Extended Programming Reference*
- *Cisco VCO/4K System Administrator's Guide*
- *Cisco VCO/4K Ethernet Guide*

RELATED DOCUMENTS

Technical Description

I/O Modules

1.0 General

VCO/4K port interface cards terminate line appearances on 96-pin DIN connectors mounted directly on the backplane of the card rack. I/O modules convert the DIN appearances to one of the following standard network connector types:

- 6-pin RJ-11X modular jacks for UTC-2, ECT/LCT, SLIC-2, SLIC-INT, DDI, and DID cards
- 50-pin RJ-21X connectors for UTC-2, ECT/LCT, SLIC-2, SLIC-INT, DDI, and DID cards
- 50-pin RJ-2nX¹ for E&M cards
- RJ-45 and DB-15 standard for the following cards — Four Span T1, Single Span T1, PRI/N, 120 ohm Four Span E1, and the 120 ohm version of the ISDN/NET5 E1-PRI
- BNC connectors for Four Span E1 and Single Span E1 cards

¹ There are four different I/O modules for E&M Cards; RJ-2EX, RJ-2FX, RJ-2GX, and RJ-2HX.

All of the connectors discussed in this technical description are standard Uniform Service Order Code (USOC) connectors.

2.0 RJ11X I/O Module Specifications

Cisco Systems Part Number:	Contact your Cisco Systems sales representative
Application:	Up to eight modular jack connections to single phone lines
Mechanical Arrangements:	One DIN connector to eight Accunet 6-pin modular jacks
MDF Circuits:	Eight parallel 6-pin modular connectors
Physical Dimensions:	15.73 inch (400 mm) high, 5.65 inch (143.5 mm) deep, .77 inch (19.6 mm) wide

2.1 RJ-11X I/O Module Descriptions

Figure 1 shows the RJ-11X I/O module.

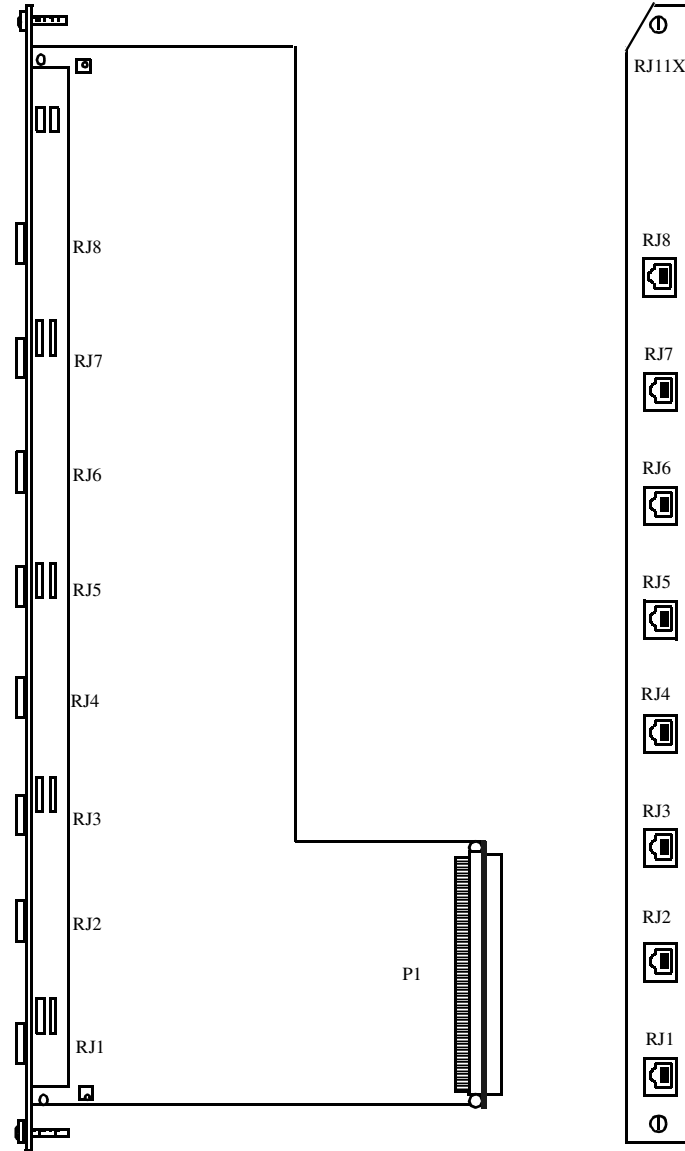

Figure 1: RJ-11X I/O Module

Figure 2 shows the RJ-11X I/O module wiring plan.

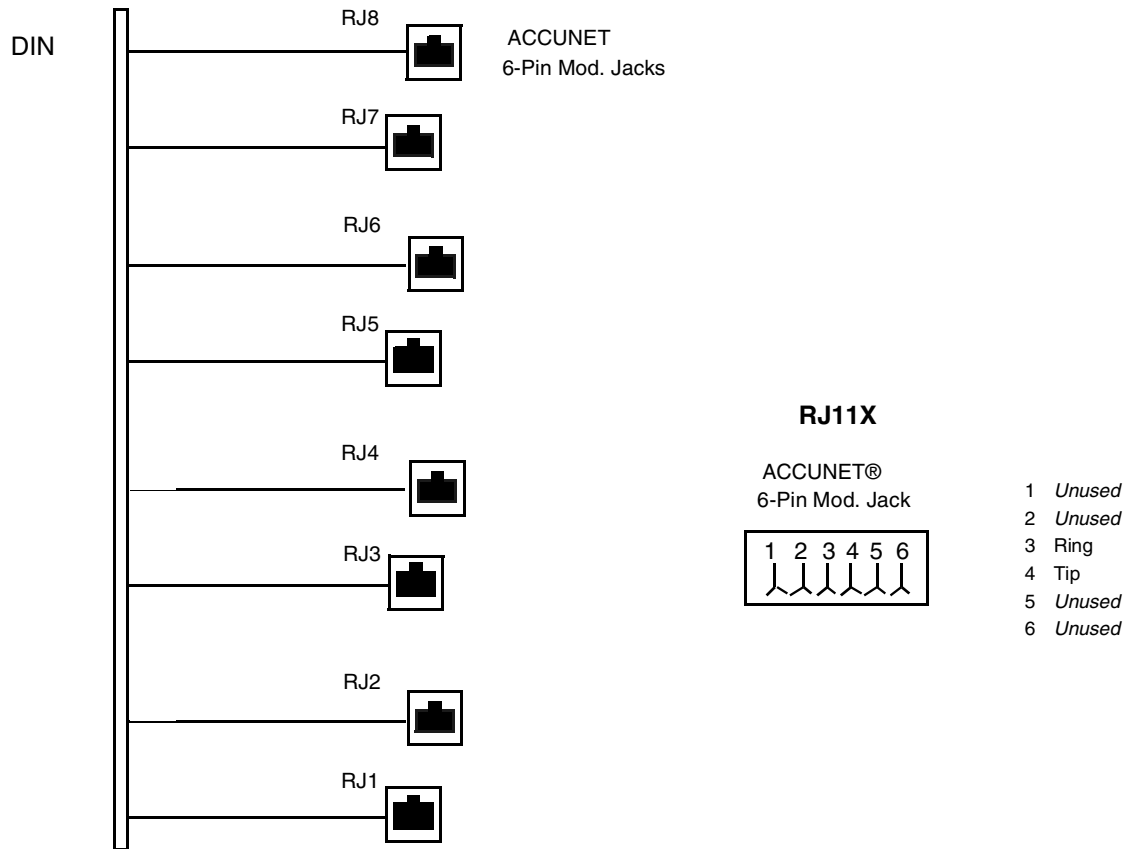

Figure 2: Wiring for the RJ-11X I/O Module

3.0 RJ-21X I/O Module

The RJ-21X I/O module consists of two parts, a PCB assembly that connects to the backplane, and a faceplate with an RJ21X connector and 96-pin ribbon cable that connects the faceplate to the PCB assembly. One RJ-21X I/O module connects *three* 2-Wire Interface cards. The specifications for the RJ-21X I/O module follow.

Cisco Systems Part Number:	Contact your Cisco Systems sales representative
Application:	Up to 24 Bridged, T/R Connections to lines and trunks
Mechanical Arrangements:	1 Plug-In PCB (3 DIN To 1 RJ21X); 1 faceplate with an J21X connector and a 96-pin ribbon cable
MDF Circuits:	24 pairs per modular connector
Construction:	Single PCB with ribbon cable and rear faceplate
PCB Physical Dimensions:	5.25 inch (133 mm) high, 1.13 inch (286 mm) deep, 2.31 inch (58.7 mm) wide
Faceplate Physical Dimensions:	15.73 inch (400 mm) high, 2.37 inch (60.2 mm) wide

3.1 RJ-21X I/O Module Descriptions

Figure 3 shows the RJ-21X I/O Module Assembly.

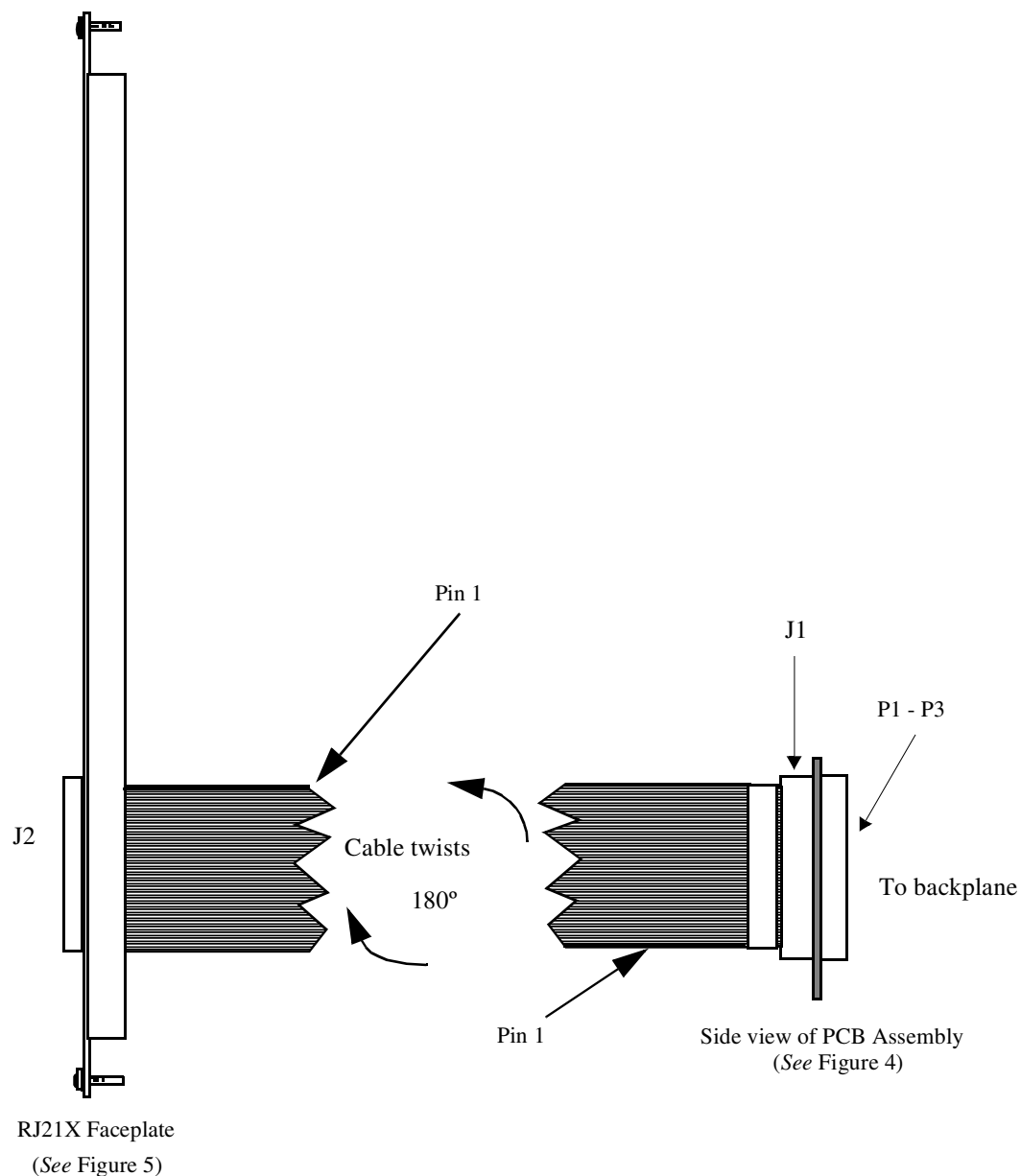

Figure 3: RJ-21X I/O Module Assembly

The PCB mounts to threaded studs on the backplane using standoffs and screws supplied with the modules. *Figure 4* shows the mechanical arrangements for the PCB Assembly.

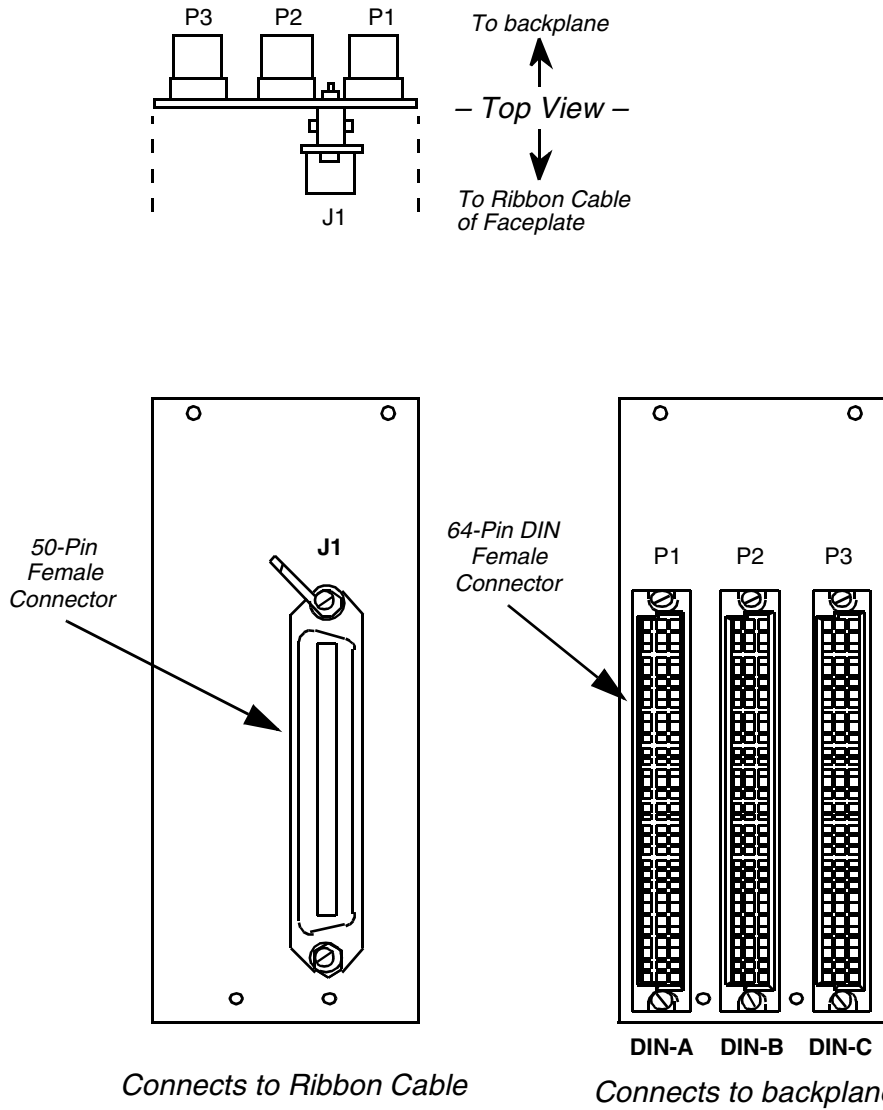

Figure 4: Mechanical Arrangement for the PCB Assembly of RJ-21X I/O Module

The PCB I/O module is connected to the rear faceplate via a 96-pin ribbon cable. The faceplate is the width of three standard card slots and mounts on the rear of the VCO/4K system.

Figure 5 shows the faceplate.

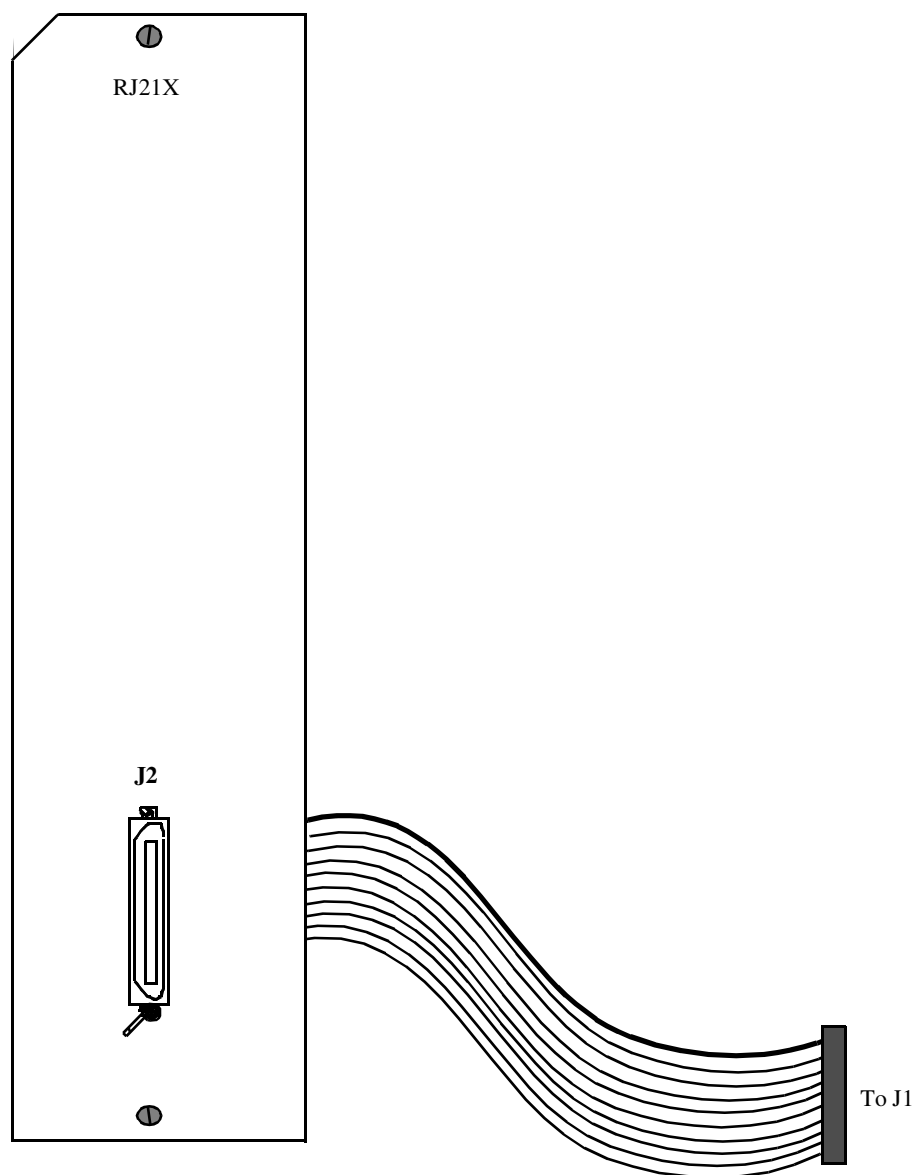

Figure 5: RJ-21X I/O Module Faceplate with Ribbon Cable

The wiring plans correspond with the USOC specifications for analog circuits and AT&T wiring for T1 digital lines. Refer to the *Cisco VCO/4K Site Preparation Guide* for additional information. *Figure 6* shows the RJ-21X module wiring plan.

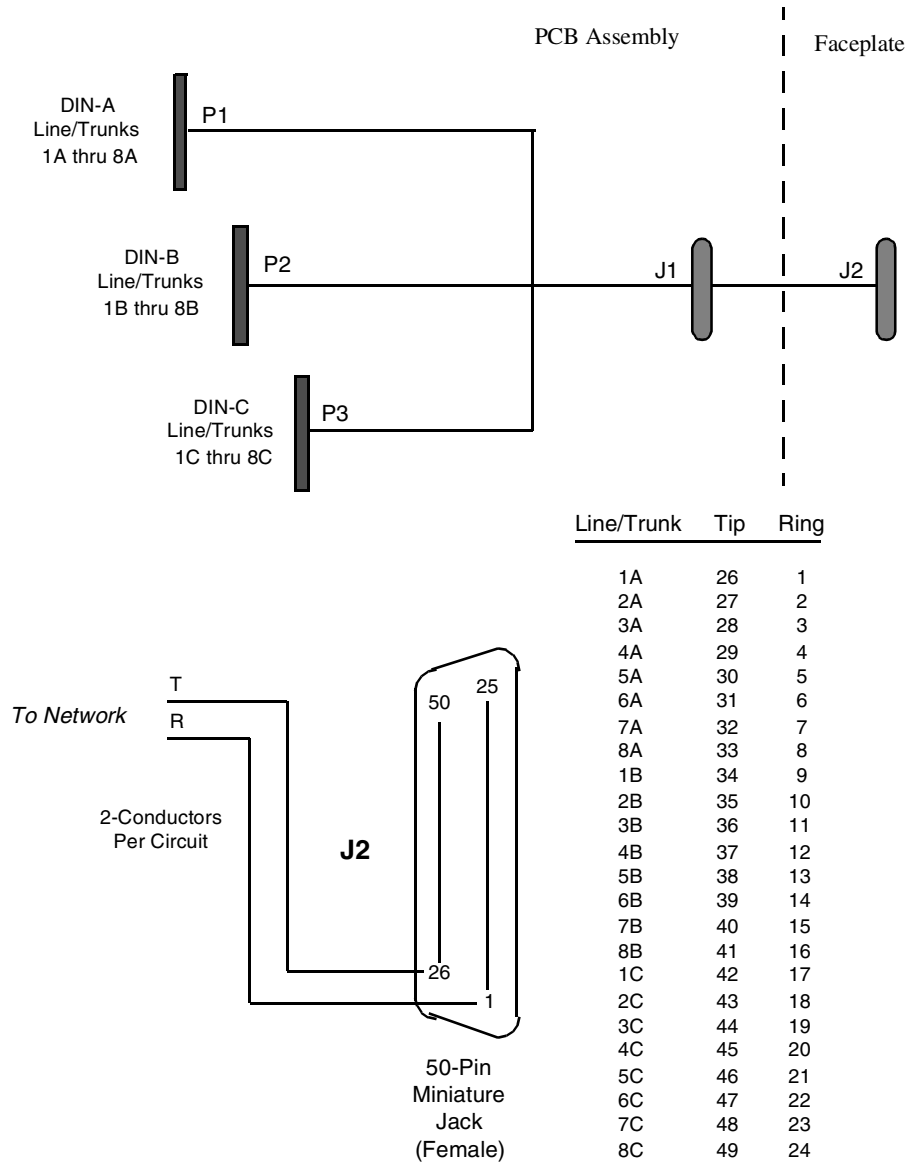

Figure 6: RJ-21X I/O Module Wiring Plan

4.0 RJ-2nX I/O Module

There are four types of RJ-2nX I/O modules with different pin assignments depending on the transmission and signal type of the E&M card. The four types are RJ-2EX, RJ-2FX, RJ-2GX, and RJ-2HX. A single RJ-2nX I/O module is tied to a single E&M card. RJ-2EX, RJ-2FX, and RJ-2GX I/O modules carry all required connections from the respective backplane connector to a single 25 pair RJ-21 type connector. The RJ-2HX I/O module requires two 25-pair connectors.

The analog plug-in I/O modules optimize standard 25-pair MDF cables. Use one 25-pair telephone standard cable to connect each analog I/O module on the VCO/4K to a block on the MDF. Specify the RJ-2nX I/O module according to the number and type of cards.

4.1 Specifications

Table 1 summarizes the specifications for the four types of RJ-2nX I/O modules.

Table 1: RJ2?X I/O Module Specifications

USOC	RJ2EX	RJ2FX	RJ2GX	RJ2HX
Cisco Systems Part Number	Contact your Cisco Systems sales representative	Contact your Cisco Systems sales representative	Contact your Cisco Systems sales representative	Contact your Cisco Systems sales representative
Application	Up to 8 Bridged Tie, 2-Wire T/R, E&M Type I or Type V signaling	Up to 8 Bridged Tie, 2-Wire T/R, E&M Type II or Type IV signaling	Up to 8 Bridged Tie, 4-Wire T/R, E&M Type I or Type V signaling ¹	Up to 4 Bridged Tie, 8-Wire T/R, E&M Type II or Type IV signaling ¹
Mechanical Arrangements	One 96-pin DIN connector to one 50 pin ribbon jack	One 96-pin DIN connector to one 50-pin ribbon jack	One 96-pin DIN connector to one 50-pin ribbon jack	One 96-pin DIN connector to two 50-pin ribbon jacks
MDF Circuits	Eight 4-wire circuits interfacing one modular connector	Eight 6-wire circuits interfacing one modular connector	Eight 6-wire circuits interfacing one modular connector	Four 8-wire circuits interfacing to two modular connectors
Physical Dimensions	15.73 inch (400 mm) high, 77 inch (19.6 mm.) wide, 5.65 inch (143.5mm) deep			

¹ In 4-wire applications, T+R= VCO/4K Receive, and T1+R1=VCO/4K Transmit

4.2 RJ-2EX, RJ-2FX, and RJ-2GX I/O Module Descriptions

The RJ2EX, RJ2FX, and RJ2GX I/O modules have the same component layout. Only the wiring plans are different. *Figure 7* shows the RJ-2EX, RJ-2FX, and RJ-2GX I/O module layout.

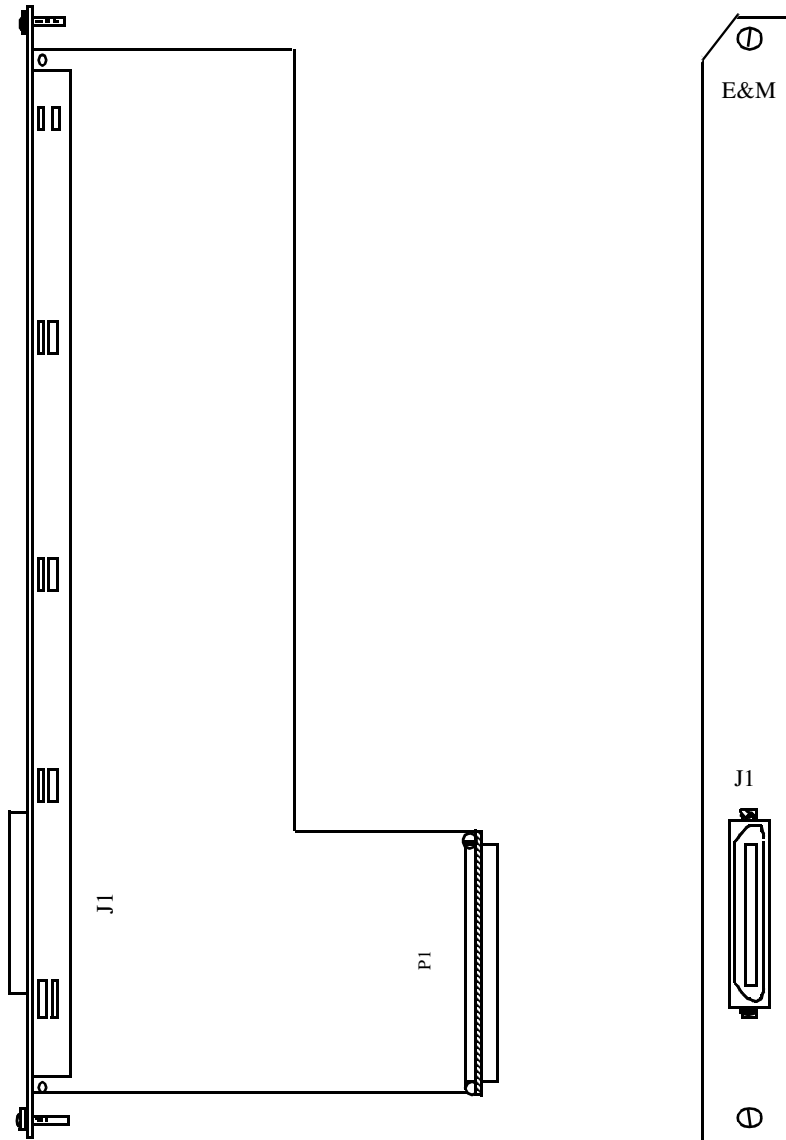

Figure 7: RJ-2EX, RJ-2FX, and RJ-2GX PCB Assemblies

Figure 8 shows the wiring plan for the RJ-2EX I/O modules.

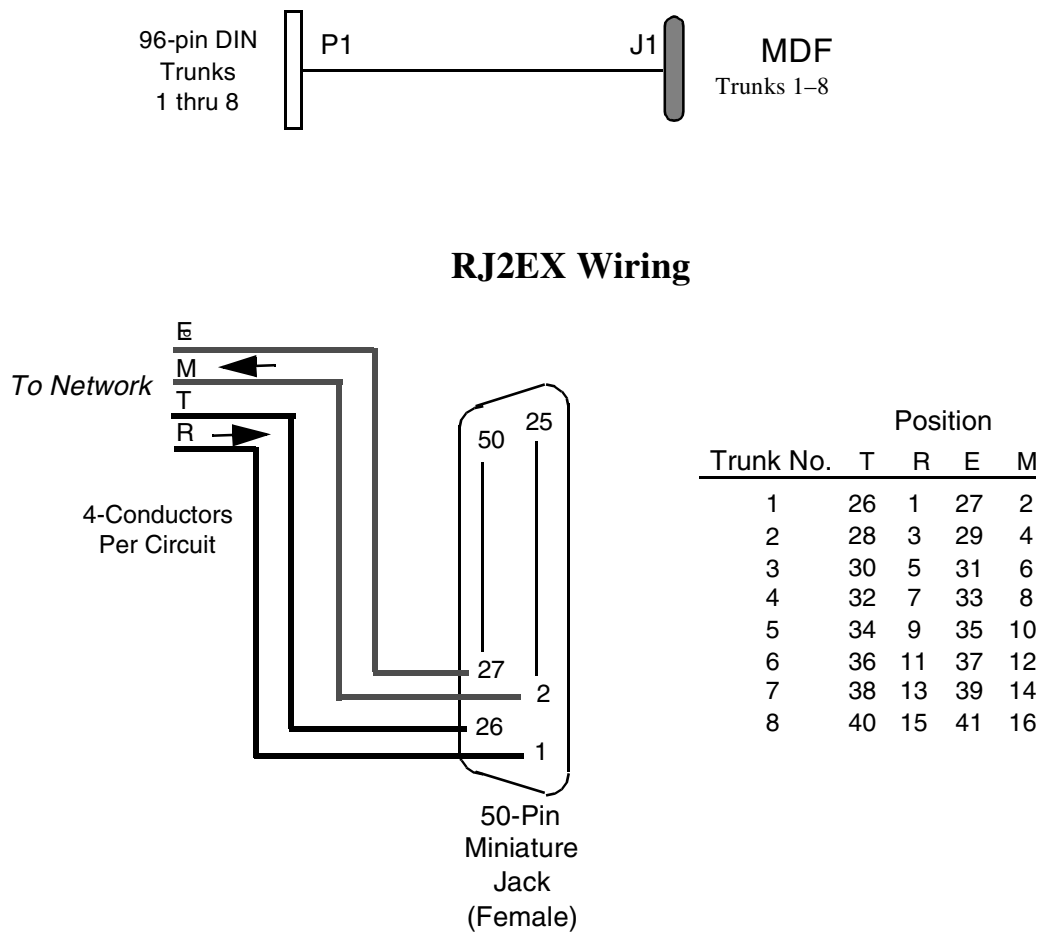

Figure 8: RJ-2EX I/O Module Wiring Plan

Figure 9 shows the wiring plan for the RJ-2FX I/O module.

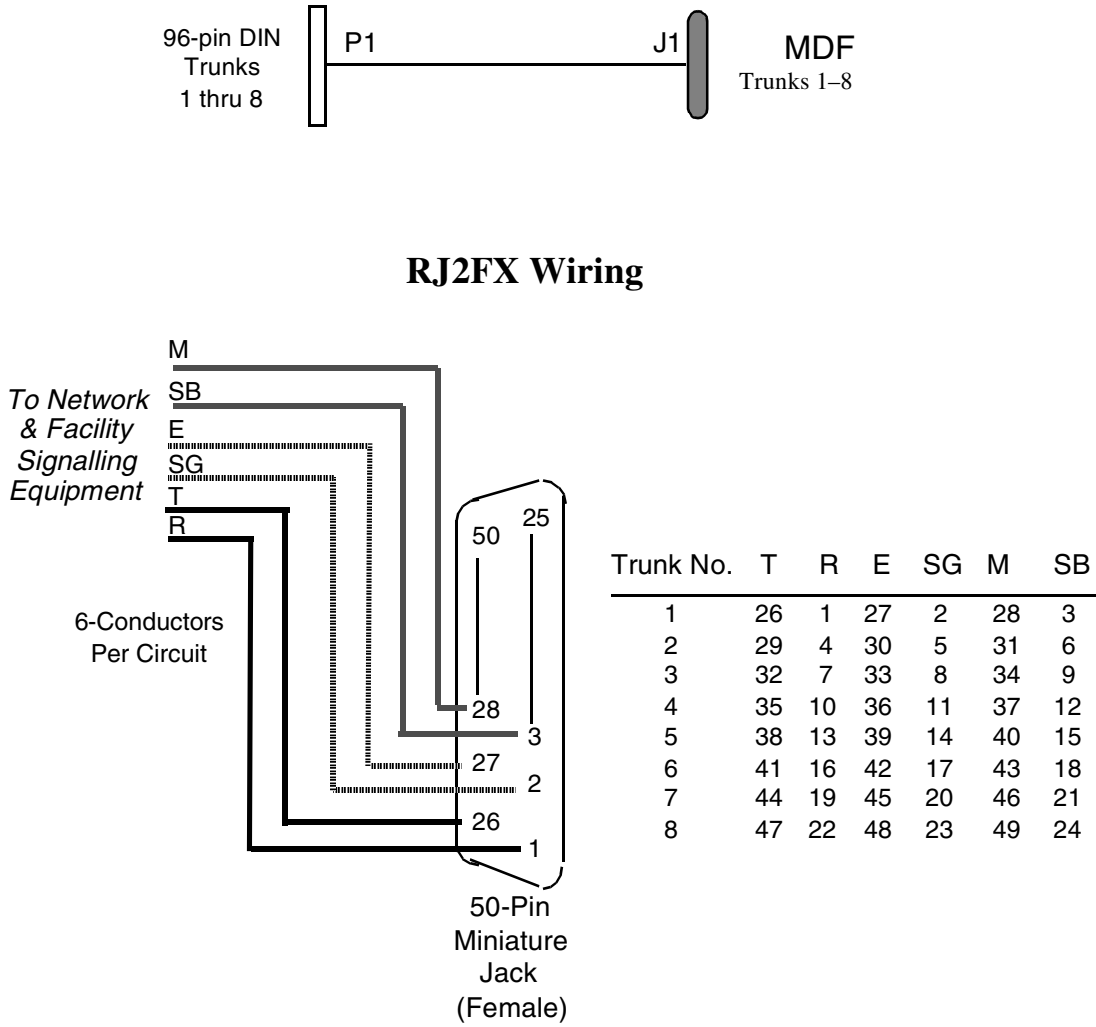

Figure 9: RJ-2FX I/O Module Wiring Plan

Figure 10 shows the wiring plan for the RJ-2GX I/O module.

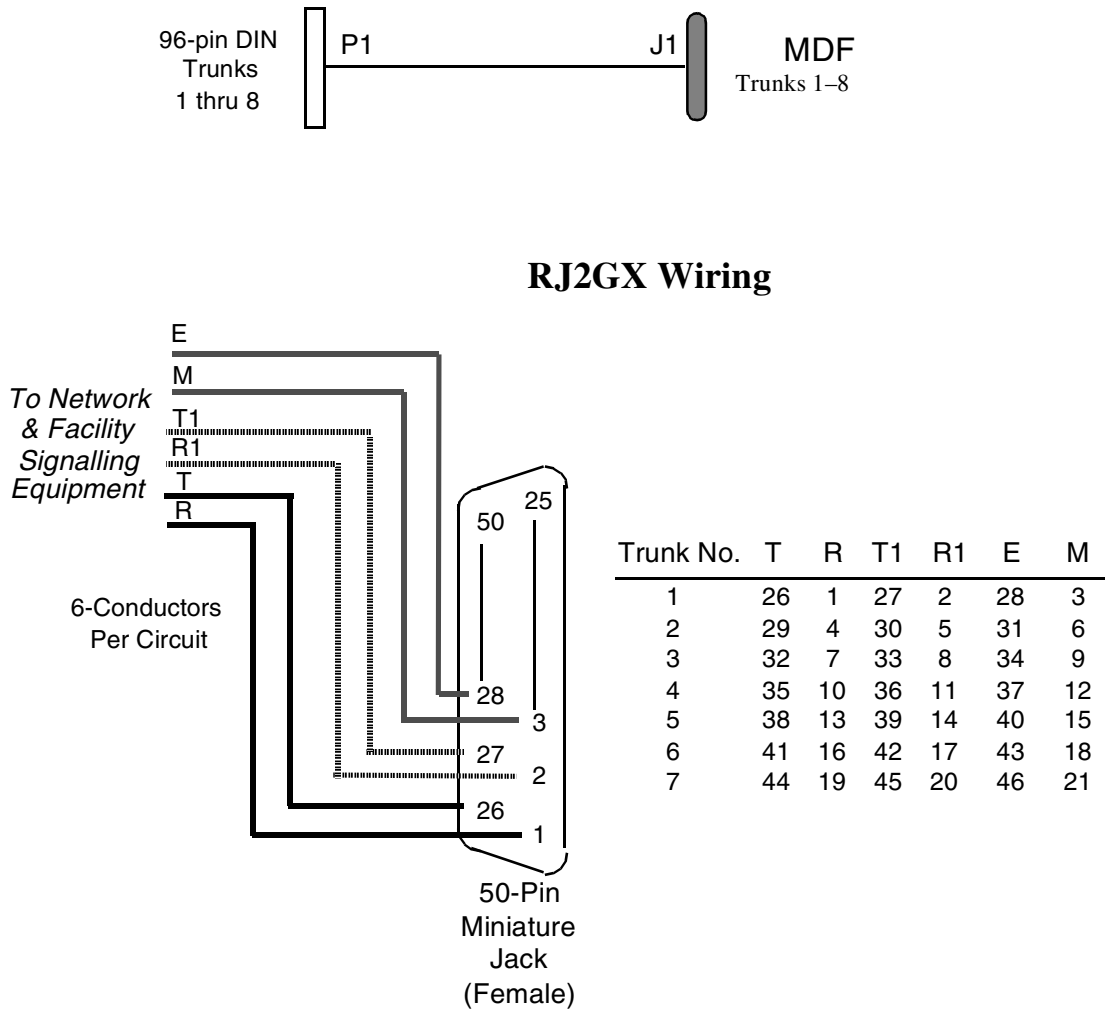

Figure 10: RJ-2GX I/O Module Wiring Plan

4.3 RJ-2HX I/O Module Description

Figure 11 shows the RJ-2HX I/O module.

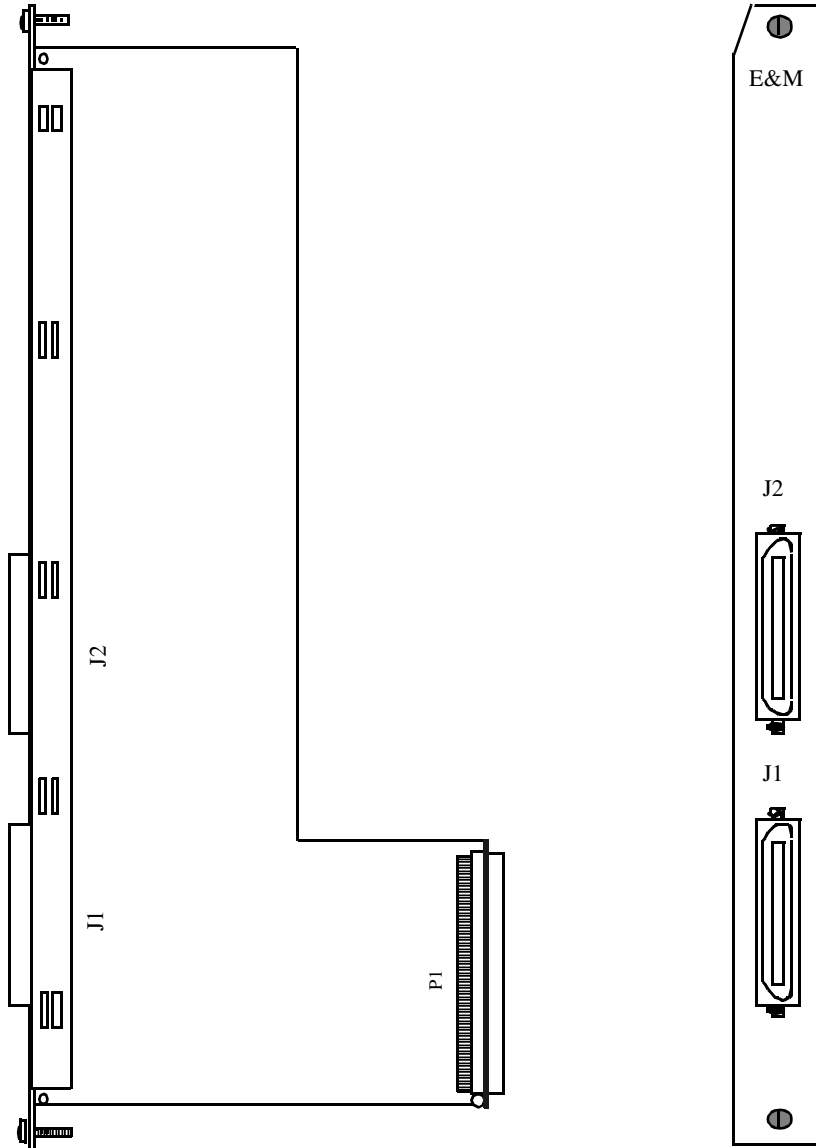

Figure 11: RJ-2HX I/O Module Assembly

Figure 12 shows the wiring plan for the RJ-2HX I/O module.

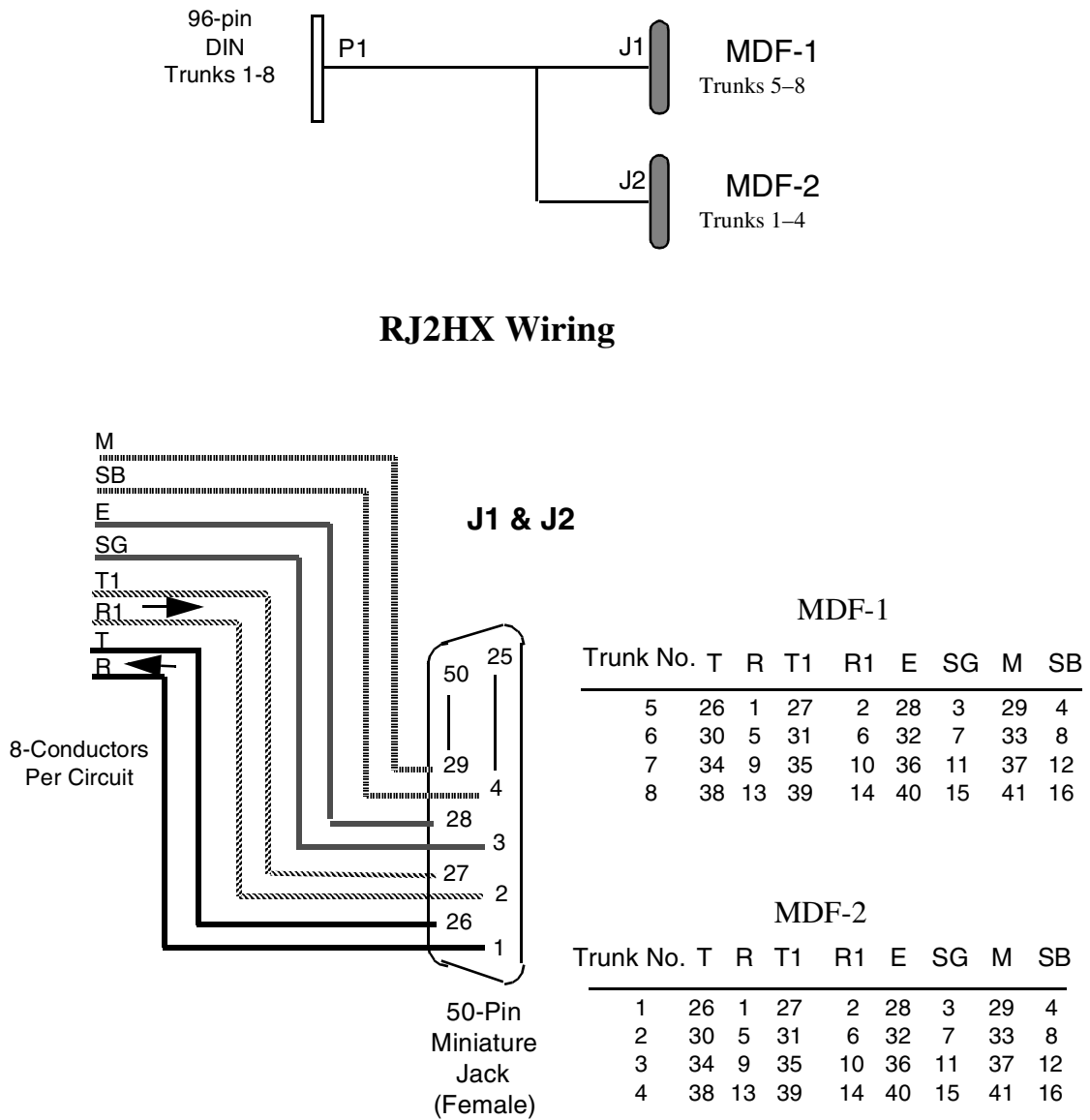

Figure 12: RJ-2HX I/O Module Wiring Plan

5.0 RJ-45/DB-15 I/O Module

A single RJ-45/DB-15 I/O module is tied to a Single Span T1 card, a PRI/N card, or a 120 ohm ISDN/NET5 E1-PRI card. The module is picked up and transitioned to RJ-45 and DB-15 connectors. Each span uses one pair of connectors; i.e., one RJ45 and one DB15. Cards utilize one or the other connector, but not both, at any one time. For example, 120 ohm E1 interfaces typically utilize the RJ-45 connector.

5.1 Specifications

The specifications for the RJ-45/DB-15 I/O module follow.

Standard Compliance:	ISO 4903, DA-15S
Cisco Systems Part Number:	Single span — Contact your Cisco Systems sales representative Four span — Contact your Cisco Systems sales representative
Application:	Connection of a T1 span or 120 ohm E1-PRI span to a VCO/4K system
Mechanical Arrangements:	Single Span T1 or 120 ohm E1-PRI — One DIN connector to one D-Sub connector and one Accunet 8-pin modular jack (RJ-45) Four Span T1 or 120 ohm Four Span E1 — One DIN connector to four D-Sub connectors and four Accunet 8-pin modular jacks
MDF Circuits:	Single Span T1 or 120 ohm E1-PRI — 24-VF Channel, DS-1 rate digital lines interfacing a paralleled set of 8-pin modular and 15-pin D-sub connectors Four span T1 or 120 ohm Four Span E1 — Four 4-wire T1 spans interfacing four paralleled sets of 8-pin modular and 15-pin D-sub connectors
Physical Dimensions:	15.73 inch (400 mm) high, .77 inch (19.6 mm) wide, 5.65 inch (143.5 mm) deep

5.2 RJ-45/DB-15 I/O Module for Single Span T1

Figure 13 shows the I/O module for the Single Span T1 card.

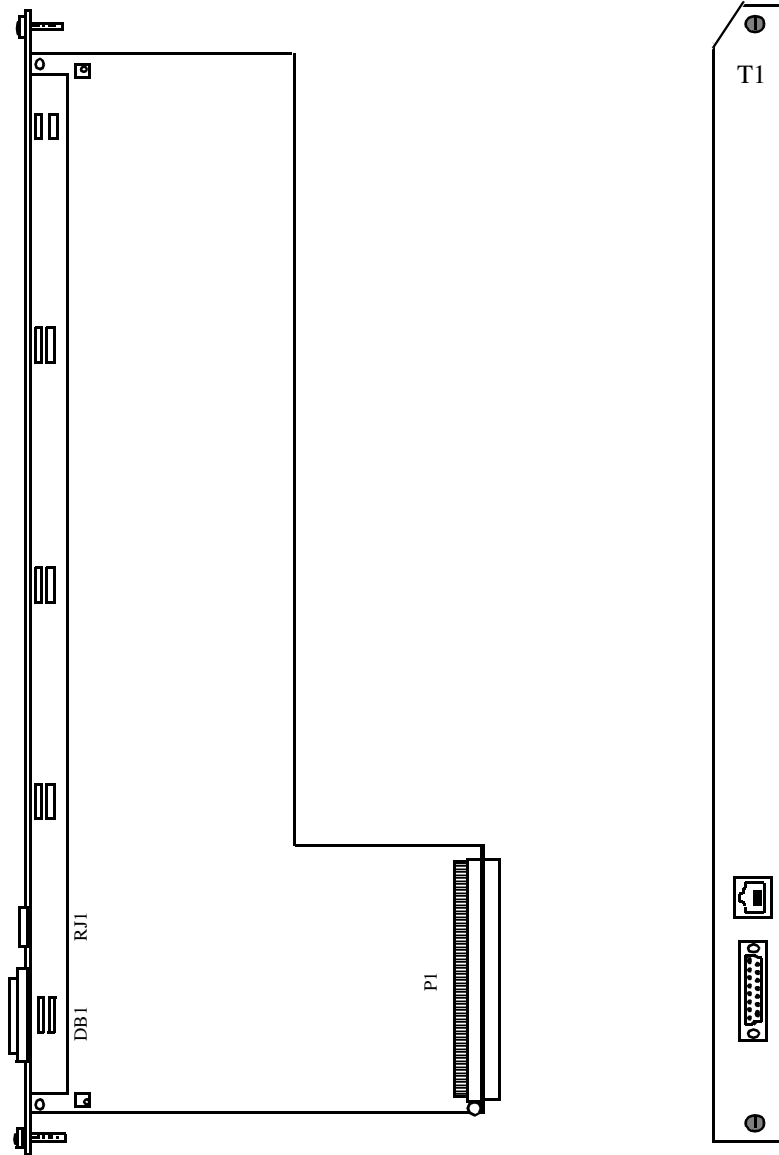

Figure 13: RJ-45/DB-15 I/O Module for Single Span T1

Figure 14 shows the wiring plan for the Single Span T1 I/O module.

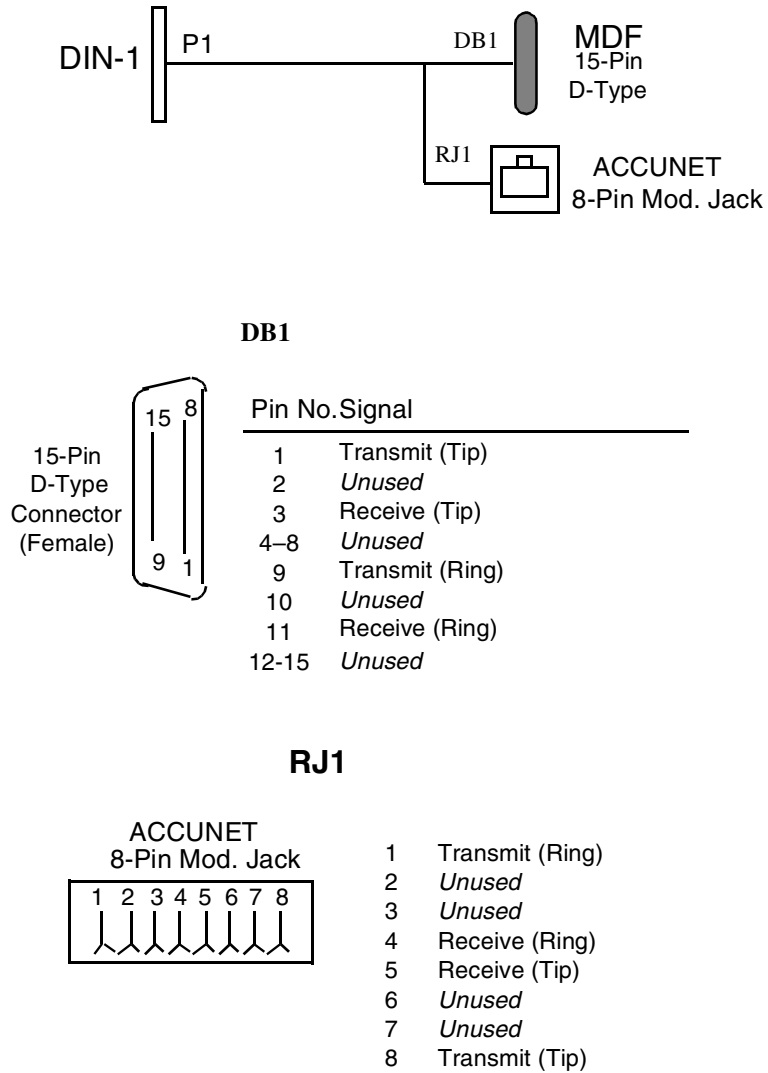

Figure 14: Wiring for RJ-45/DB-15 I/O Module for Single Span T1

5.3 RJ-45/DB-15 I/O Module for Four Span T1

Figure 15 shows the I/O module for the Four Span T1 Card.

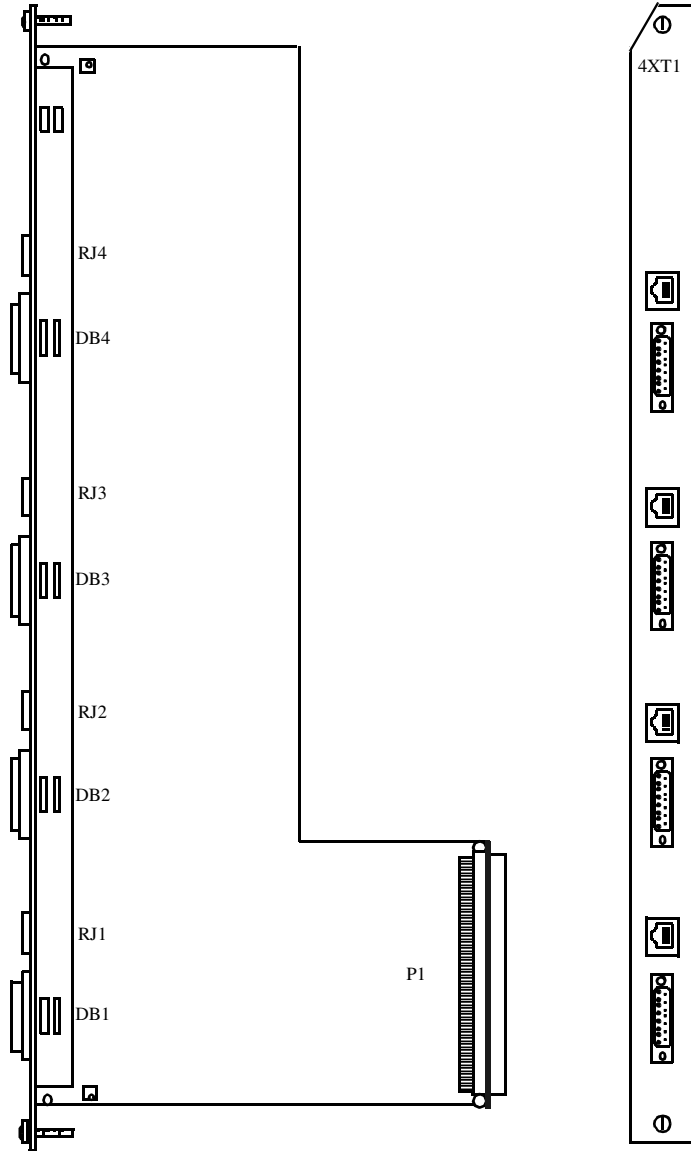

Figure 15: RJ-45/DB-15 I/O Module for Four Span T1

Figure 16 shows the wiring plan for the I/O module for the Four Span T1 Card.

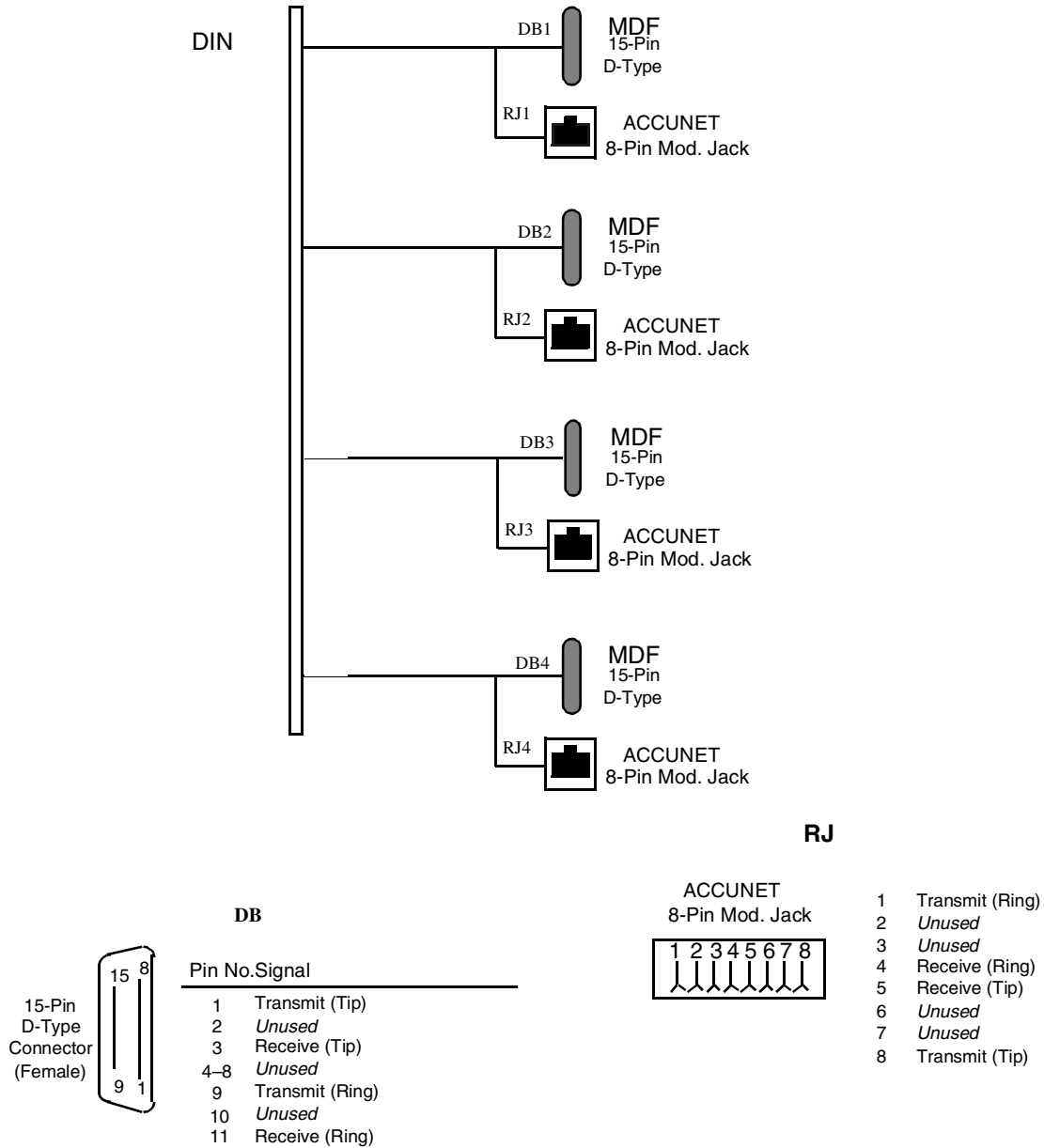

Figure 16: Wiring for RJ-45/DB-15 I/O Module for Four Span T1

6.0 BNC I/O Module

A single BNC I/O module is tied to a single Four Span E1 or Single Span E1 card. The backplane connector is picked up and transitioned to BNC connector pairs (TX and RX). Each connector pair supports one E1 span.

6.1 Specifications

The specifications for the RJ-45/DB-15 I/O module follow.

Cisco Systems Part Number:	Single span - Contact your Cisco Systems sales representative Four span - Contact your Cisco Systems sales representative
Application:	Connection of a E1 line to a VCO/4K system
Mechanical Arrangements:	Single span E1 – One DIN connector to a pair of TX/RX BNC connectors Four Span E1 – One DIN connector to four pairs of TX/RX BNC connectors
MDF Circuits:	Single span E1 – 32 -VF Channel 2048 MBPS digital lines interfacing to 75 ohm coaxial Transmit and Receive Connectors Four span E1 – Four E1 spans interfacing four parallel sets of 75 ohm coaxial Transmit and Receive Connectors
Physical Dimensions:	15.73 inch (400 mm) high, .77 inch (19.6 mm) wide, 5.65 inch (143.5 mm) deep

6.2 BNC I/O Module For Single Span E1

Figure 17 shows the I/O module for single span E1 cards.

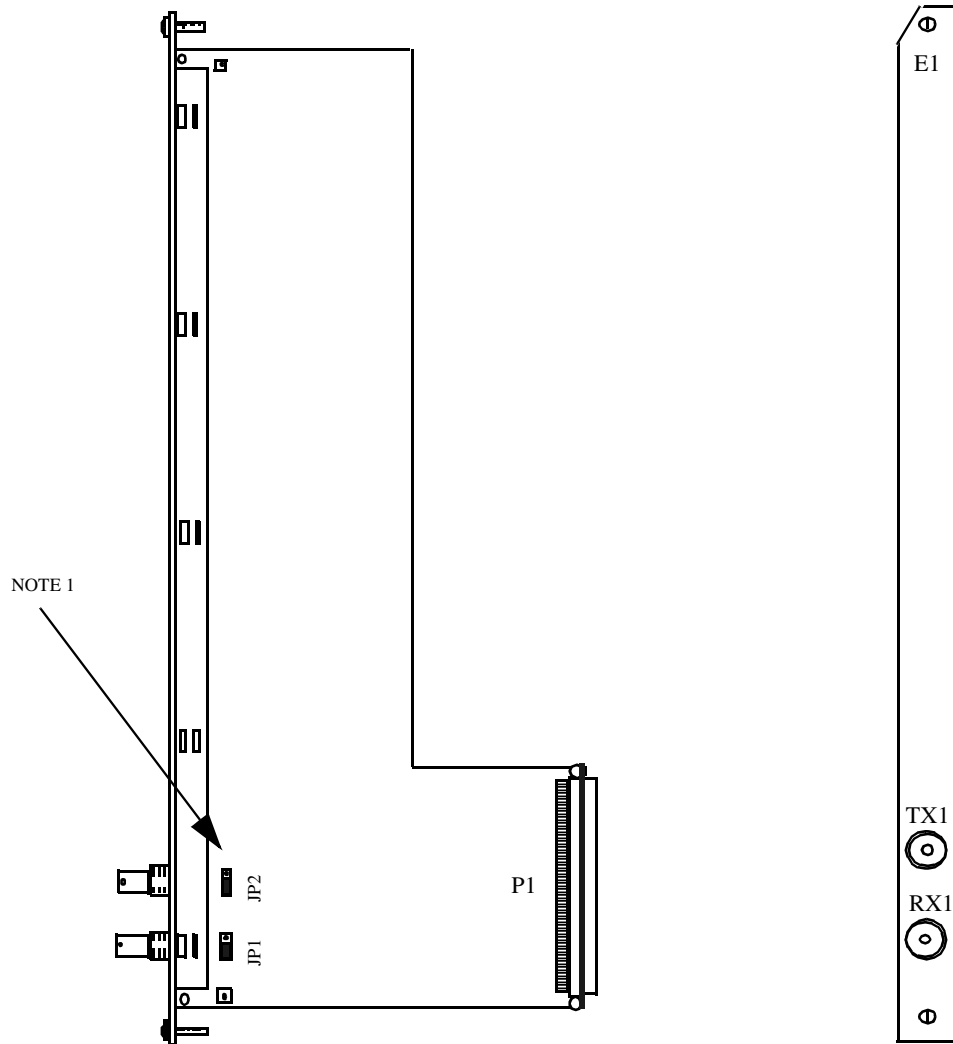

Figure 17: BNC I/O Module (Single Span E1)

NOTE 1

Jumper settings for JP1 and JP2 are as follows:

Pin 1 and 2	Ties ring to DC ground
Pin 2 and 3	Ties ring to AC ground
jumper removed	Allows ring to float

The default jumper setting is pin 1 and 2.

Figure 18 shows the wiring plan for the BNC I/O module for Single Span E1 cards.

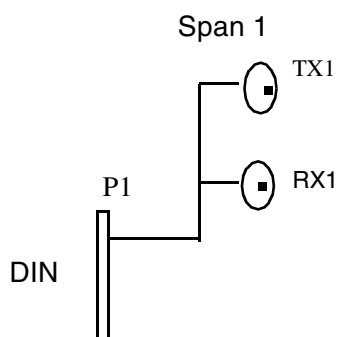

Figure 18: Wiring for BNC I/O Module (Single Span E1)

6.3 BNC I/O Module For Four Span E1

Figure 19 shows the I/O module for Four Span E1 cards.

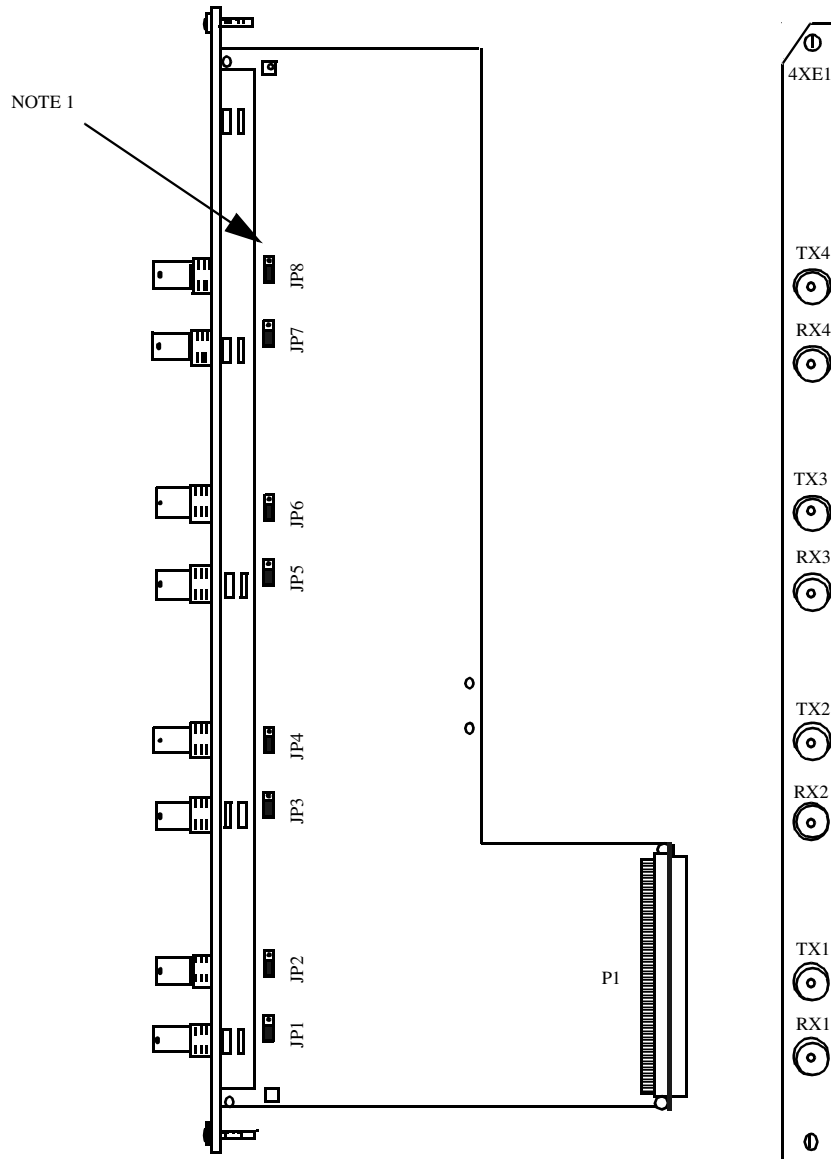

Figure 19: BNC I/O Module (Four Span E1)

NOTE 1

Jumper settings for JP1 through JP8 are as follows:

Pin 1 and 2	Ties ring to DC ground
Pin 2 and 3	Ties ring to AC ground
jumper removed	Allows ring to float

The default jumper settings are pins 1 and 2.

Figure 20 shows the wiring plan for the BNC I/O module for the Four Span E1 card.

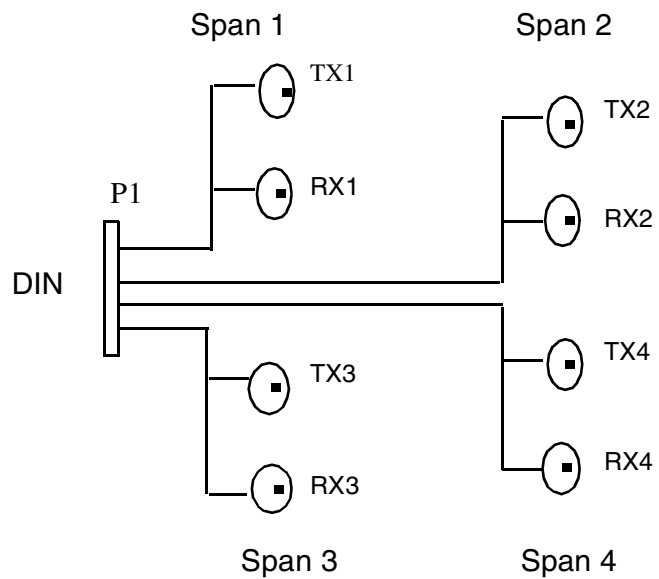

Figure 20: Wiring for BNC I/O Module (Four Span E1)

7.0 Removal and Replacement Procedures

7.1 Removing an I/O Module

Follow these steps to remove an I/O module.

NOTE: An I/O module is generally not subject to failure. A DIN or MDF connector may become loose if excessive force is applied to the MDF cable(s). If intermittent problems occur with network services, check the network lines/trunks, MDF cross-wiring, and MDF cable before removing the module.

1. Take the port interface cards, in the module locations, out-of-service (OOS). For information about taking cards OOS, refer to the *Cisco VCO/4K System Administrator's Guide*.
2. From the back of the system, unscrew the top and bottom fasteners for the card.

NOTE: The same mounting hardware is used for all I/O module assemblies.

3. Pull the module away from the backplane.

CAUTION: Do not attempt to pry the I/O module from the backplane using a screwdriver or some other tool. The tip of the prying tool could damage the backplane and/or DIN connectors.

7.2 Adding or Replacing an I/O Module

Use these steps to replace/add an I/O module.

1. Press the module firmly into the DIN connectors on the backplane.
2. Tighten the mounting screws.
3. Connect the MDF cables onto the appropriate connectors on the adapter.

NOTE: Verify that the system database entries correspond to the type of module and port interface cards installed at the adapter's R-L-S locations.

8.0 Troubleshooting

If problems occur with the network interface, check all cable and cross-wiring connections to and from the MDF. Examine a suspect module for signs of physical damage (cracked connectors, damaged wires, etc.). Correct the cause of the damage by reconnecting MDF cables and cross-wiring and/or rerouting cables to avoid future problems.