



AP1020/1030 Cisco Aironet 1000 Series IEEE 802.11a/b/g Lightweight Access Points with External Antennas - Quick Start Guide

Corporate Headquarters
Cisco Systems, Inc.
170 West Tasman Drive
San Jose, CA 95134-1706
USA
<http://www.cisco.com>
Tel: 408 526-4000
800 553-NETS (6387)
Fax: 408 526-4100

Text Part Number: 78-17147-01



THE SPECIFICATIONS AND INFORMATION REGARDING THE PRODUCTS IN THIS MANUAL ARE SUBJECT TO CHANGE WITHOUT NOTICE. ALL STATEMENTS, INFORMATION, AND RECOMMENDATIONS IN THIS MANUAL ARE BELIEVED TO BE ACCURATE BUT ARE PRESENTED WITHOUT WARRANTY OF ANY KIND, EXPRESS OR IMPLIED. USERS MUST TAKE FULL RESPONSIBILITY FOR THEIR APPLICATION OF ANY PRODUCTS.

THE SOFTWARE LICENSE AND LIMITED WARRANTY FOR THE ACCOMPANYING PRODUCT ARE SET FORTH IN THE INFORMATION PACKET THAT SHIPPED WITH THE PRODUCT AND ARE INCORPORATED HEREIN BY THIS REFERENCE. IF YOU ARE UNABLE TO LOCATE THE SOFTWARE LICENSE OR LIMITED WARRANTY, CONTACT YOUR CISCO REPRESENTATIVE FOR A COPY.

The following information is for FCC compliance of Class A devices: This equipment has been tested and found to comply with the limits for a Class A digital device, pursuant to part 15 of the FCC rules. These limits are designed to provide reasonable protection against harmful interference when the equipment is operated in a commercial environment. This equipment generates, uses, and can radiate radio-frequency energy and, if not installed and used in accordance with the instruction manual, may cause harmful interference to radio communications. Operation of this equipment in a residential area is likely to cause harmful interference, in which case users will be required to correct the interference at their own expense.

The following information is for FCC compliance of Class B devices: The equipment described in this manual generates and may radiate radio-frequency energy. If it is not installed in accordance with Cisco's installation instructions, it may cause interference with radio and television reception. This equipment has been tested and found to comply with the limits for a Class B digital device in accordance with the specifications in part 15 of the FCC rules. These specifications are designed to provide reasonable protection against such interference in a residential installation. However, there is no guarantee that interference will not occur in a particular installation.

Modifying the equipment without Cisco's written authorization may result in the equipment no longer complying with FCC requirements for Class A or Class B digital devices. In that event, your right to use the equipment may be limited by FCC regulations, and you may be required to correct any interference to radio or television communications at your own expense.

You can determine whether your equipment is causing interference by turning it off. If the interference stops, it was probably caused by the Cisco equipment or one of its peripheral devices. If the equipment causes interference to radio or television reception, try to correct the interference by using one or more of the following measures:

- Turn the television or radio antenna until the interference stops.
- Move the equipment to one side or the other of the television or radio.
- Move the equipment farther away from the television or radio.
- Plug the equipment into an outlet that is on a different circuit from the television or radio. (That is, make certain the equipment and the television or radio are on circuits controlled by different circuit breakers or fuses.)

Modifications to this product not authorized by Cisco Systems, Inc. could void the FCC approval and negate your authority to operate the product.

The Cisco implementation of TCP header compression is an adaptation of a program developed by the University of California, Berkeley (UCB) as part of UCB's public domain version of the UNIX operating system. All rights reserved. Copyright © 1981, Regents of the University of California.

NOTWITHSTANDING ANY OTHER WARRANTY HEREIN, ALL DOCUMENT FILES AND SOFTWARE OF THESE SUPPLIERS ARE PROVIDED "AS IS" WITH ALL FAULTS. CISCO AND THE ABOVE-NAMED SUPPLIERS DISCLAIM ALL WARRANTIES, EXPRESSED OR IMPLIED, INCLUDING, WITHOUT LIMITATION, THOSE OF MERCHANTABILITY, FITNESS FOR A PARTICULAR PURPOSE AND NONINFRINGEMENT OR ARISING FROM A COURSE OF DEALING, USAGE, OR TRADE PRACTICE.

IN NO EVENT SHALL CISCO OR ITS SUPPLIERS BE LIABLE FOR ANY INDIRECT, SPECIAL, CONSEQUENTIAL, OR INCIDENTAL DAMAGES, INCLUDING, WITHOUT LIMITATION, LOST PROFITS OR LOSS OR DAMAGE TO DATA ARISING OUT OF THE USE OR INABILITY TO USE THIS MANUAL, EVEN IF CISCO OR ITS SUPPLIERS HAVE BEEN ADVISED OF THE POSSIBILITY OF SUCH DAMAGES.

CCSP, CCVP, the Cisco Square Bridge logo, Follow Me Browsing, and StackWise are trademarks of Cisco Systems, Inc.; Changing the Way We Work, Live, Play, and Learn, and iQuick Study are service marks of Cisco Systems, Inc.; and Access Registrar, Aironet, ASIST, BPX, Catalyst, CCDA, CCDP, CCIE, CCIP, CCNA, CCNP, Cisco, the Cisco Certified Internetwork Expert logo, Cisco IOS, Cisco Press, Cisco Systems, Cisco Systems Capital, the Cisco Systems logo, Cisco Unity, Empowering the Internet Generation, Enterprise/Solver, EtherChannel, EtherFast, EtherSwitch, Fast Step, FormShare, GigaDrive, GigaStack, HomeLink, Internet Quotient, IOS, IP/TV, iQ Expertise, the iQ logo, iQ Net Readiness Scorecard, LightStream, Linksys, MeetingPlace, MGX, the Networkers logo, Networking Academy, Network Registrar, *Packet*, PIX, Post-Routing, Pre-Routing, ProConnect, RateMUX, ScriptShare, SlideCast, SMARTnet, StrataView Plus, TeleRouter, The Fastest Way to Increase Your Internet Quotient, and TransPath are registered trademarks of Cisco Systems, Inc. and/or its affiliates in the United States and certain other countries.

All other trademarks mentioned in this document or Website are the property of their respective owners. The use of the word partner does not imply a partnership relationship between Cisco and any other company. (0502R)



Preface	v
Organization	v
Conventions	v
Obtaining Documentation	vi
Cisco.com	vi
Documentation DVD	vi
Ordering Documentation	vii
Documentation Feedback	vii
Cisco Product Security Overview	vii
Reporting Security Problems in Cisco Products	viii
Obtaining Technical Assistance	viii
Cisco Technical Support Website	viii
Submitting a Service Request	ix
Definitions of Service Request Severity	ix
Obtaining Additional Publications and Information	x
Installation and Configuration	1
ATTENTION!	2
Collecting Required Tools and Supplies	4
Pre-Installation Configuration	5
Preparing a Version 3.0 Cisco Aironet 1000 Series Lightweight Access Point	5
Alternate Method of Preparing a Version 3.0 Cisco Aironet 1000 Series Lightweight Access Point	8
Preparing Mounting Locations	12
Mounting the Cisco Aironet 1000 Series Lightweight Access Points	14
Ceiling Mount Base	14
Ceiling-Mount Clips	16
Projection Wall Mount	18
Flush Wall Mount	20
Returning MAC Information	22
APPENDIX A	Planning Notes A-1
	About Cables A-1
	About External Antennas A-2
	About Mounting Options A-3

About Mounting Options A-3
About Physical Security A-4
FCC Statements for Cisco Aironet 1000 Series Lightweight Access Points A-4
EU Regulatory Information A-5
Industry Canada Required User Information for Cisco Aironet 1000 Series Lightweight Access Points A-6
Safety Considerations A-6

INDEX



Preface

This Guide contains several sections which will help you to install AP1020 and AP1030 Cisco Aironet 1000 Series IEEE 802.11a/b/g lightweight access points. These models contain internal 802.11a and 802.11b/g antennas and connectors for optional external 802.11a and 802.11b/g antennas.

When you are installing AP1010 internal-antenna Cisco Aironet 1000 Series 802.11a/b/g lightweight access points with internal 802.11a and 802.11b/g antennas and no connectors for optional external 802.11a and 802.11b/g antennas, please refer to the *AP1010 Cisco Aironet 1000 Series IEEE 802.11a/b/g Lightweight Access Point Installation and Configuration Guide*.

Organization

This guide is organized into the following sections:

- [Installation and Configuration](#)
- [Collecting Required Tools and Supplies](#)
- [Pre-Installation Configuration](#)
- [Preparing Mounting Locations](#)
- [Mounting the Cisco Aironet 1000 Series Lightweight Access Points](#)
- [Returning MAC Information](#)

Conventions

This publication uses these conventions to convey instructions and information:

Command descriptions use these conventions:

- Commands and keywords are in boldface text.
- Arguments for which you supply values are in italic.
- Square brackets ([]) mean optional elements.
- Braces ({ }) group required choices, and vertical bars (|) separate the alternative elements.
- Braces and vertical bars within square brackets ([{ | }]) mean a required choice within an optional element.

Interactive examples use these conventions:

- Terminal sessions and system displays are in screen font.

- Information you enter is in boldface screen font.
- Nonprinting characters, such as passwords or tabs, are in angle brackets (< >).

Notes, cautions, and timesavers use these conventions and symbols:



Tip

Means the following will help you solve a problem. The tips information might not be troubleshooting or even an action, but could be useful information.



Note

Means reader take note. Notes contain helpful suggestions or references to materials not contained in this manual.



Caution

Means reader be careful. In this situation, you might do something that could result equipment damage or loss of data.



Warning

This warning symbol means danger. You are in a situation that could cause bodily injury. Before you work on any equipment, be aware of the hazards involved with electrical circuitry and be familiar with standard practices for preventing accidents.

Obtaining Documentation

Cisco documentation and additional literature are available on Cisco.com. Cisco also provides several ways to obtain technical assistance and other technical resources. These sections explain how to obtain technical information from Cisco Systems.

Cisco.com

You can access the most current Cisco documentation at this URL:

<http://www.cisco.com/univercd/home/home.htm>

You can access the Cisco website at this URL:

<http://www.cisco.com>

You can access international Cisco websites at this URL:

http://www.cisco.com/public/countries_languages.shtml

Documentation DVD

Cisco documentation and additional literature are available in a Documentation DVD package, which may have shipped with your product. The Documentation DVD is updated regularly and may be more current than printed documentation. The Documentation DVD package is available as a single unit.

Registered Cisco.com users (Cisco direct customers) can order a Cisco Documentation DVD (product number DOC-DOCDVD=) from the Ordering tool or Cisco Marketplace.

Cisco Ordering tool:

<http://www.cisco.com/en/US/partner/ordering/>

Cisco Marketplace:

<http://www.cisco.com/go/marketplace/>

Ordering Documentation

You can find instructions for ordering documentation at this URL:

http://www.cisco.com/univercd/cc/td/doc/es_inpk/pdi.htm

You can order Cisco documentation in these ways:

- Registered Cisco.com users (Cisco direct customers) can order Cisco product documentation from the Ordering tool:
<http://www.cisco.com/en/US/partner/ordering/>
- Nonregistered Cisco.com users can order documentation through a local account representative by calling Cisco Systems Corporate Headquarters (California, USA) at 408 526-7208 or, elsewhere in North America, by calling 1 800 553-NETS (6387).

Documentation Feedback

You can send comments about technical documentation to bug-doc@cisco.com.

You can submit comments by using the response card (if present) behind the front cover of your document or by writing to the following address:

Cisco Systems
Attn: Customer Document Ordering
170 West Tasman Drive
San Jose, CA 95134-9883

We appreciate your comments.

Cisco Product Security Overview

Cisco provides a free online Security Vulnerability Policy portal at this URL:

http://www.cisco.com/en/US/products/products_security_vulnerability_policy.html

- From this site, you can perform these tasks:
- Report security vulnerabilities in Cisco products.
- Obtain assistance with security incidents that involve Cisco products.
- Register to receive security information from Cisco.

A current list of security advisories and notices for Cisco products is available at this URL:

<http://www.cisco.com/go/psirt>

If you prefer to see advisories and notices as they are updated in real time, you can access a Product Security Incident Response Team Really Simple Syndication (PSIRT RSS) feed from this URL:

http://www.cisco.com/en/US/products/products_psirt_rss_feed.html

Reporting Security Problems in Cisco Products

Cisco is committed to delivering secure products. We test our products internally before we release them, and we strive to correct all vulnerabilities quickly. If you think that you might have identified a vulnerability in a Cisco product, contact PSIRT:

- Emergencies — security-alert@cisco.com
- Nonemergencies — psirt@cisco.com



Tip

We encourage you to use Pretty Good Privacy (PGP) or a compatible product to encrypt any sensitive information that you send to Cisco. PSIRT can work from encrypted information that is compatible with PGP versions 2.x through 8.x.

Never use a revoked or an expired encryption key. The correct public key to use in your correspondence with PSIRT is the one that has the most recent creation date in this public key server list:

<http://pgp.mit.edu:11371/pks/lookup?search=psirt%40cisco.com&op=index&exact=on>

In an emergency, you can also reach PSIRT by telephone:

- 1 877 228-7302
- 1 408 525-6532

Obtaining Technical Assistance

For all customers, partners, resellers, and distributors who hold valid Cisco service contracts, Cisco Technical Support provides 24-hour-a-day, award-winning technical assistance. The Cisco Technical Support Website on Cisco.com features extensive online support resources. In addition, Cisco Technical Assistance Center (TAC) engineers provide telephone support. If you do not hold a valid Cisco service contract, contact your reseller.

Cisco Technical Support Website

The Cisco Technical Support Website provides online documents and tools for troubleshooting and resolving technical issues with Cisco products and technologies. The website is available 24 hours a day, 365 days a year, at this URL:

<http://www.cisco.com/techsupport>

Access to all tools on the Cisco Technical Support Website requires a Cisco.com user ID and password. If you have a valid service contract but do not have a user ID or password, you can register at this URL:

<http://tools.cisco.com/RPF/register/register.do>

**Note**

Use the Cisco Product Identification (CPI) tool to locate your product serial number before submitting a web or phone request for service. You can access the CPI tool from the Cisco Technical Support Website by clicking the **Tools & Resources** link under Documentation & Tools. Choose **Cisco Product Identification Tool** from the Alphabetical Index drop-down list, or click the **Cisco Product Identification Tool** link under Alerts & RMAs. The CPI tool offers three search options: by product ID or model name; by tree view; or for certain products, by copying and pasting **show** command output. Search results show an illustration of your product with the serial number label location highlighted. Locate the serial number label on your product and record the information before placing a service call.

Submitting a Service Request

Using the online TAC Service Request Tool is the fastest way to open S3 and S4 service requests. (S3 and S4 service requests are those in which your network is minimally impaired or for which you require product information.) After you describe your situation, the TAC Service Request Tool provides recommended solutions. If your issue is not resolved using the recommended resources, your service request is assigned to a Cisco TAC engineer. The TAC Service Request Tool is located at this URL:

<http://www.cisco.com/techsupport/servicerequest>

For S1 or S2 service requests or if you do not have Internet access, contact the Cisco TAC by telephone. (S1 or S2 service requests are those in which your production network is down or severely degraded.) Cisco TAC engineers are assigned immediately to S1 and S2 service requests to help keep your business operations running smoothly.

To open a service request by telephone, use one of the following numbers:

Asia-Pacific: +61 2 8446 7411 (Australia: 1 800 805 227)

EMEA: +32 2 704 55 55

USA: 1 800 553-2447

For a complete list of Cisco TAC contacts, go to this URL:

<http://www.cisco.com/techsupport/contacts>

Definitions of Service Request Severity

To ensure that all service requests are reported in a standard format, Cisco has established severity definitions.

- Severity 1 (S1)—Your network is “down,” or there is a critical impact to your business operations. You and Cisco will commit all necessary resources around the clock to resolve the situation.
- Severity 2 (S2)—Operation of an existing network is severely degraded, or significant aspects of your business operation are negatively affected by inadequate performance of Cisco products. You and Cisco will commit full-time resources during normal business hours to resolve the situation.
- Severity 3 (S3)—Operational performance of your network is impaired, but most business operations remain functional. You and Cisco will commit resources during normal business hours to restore service to satisfactory levels.
- Severity 4 (S4)—You require information or assistance with Cisco product capabilities, installation, or configuration. There is little or no effect on your business operations.

Obtaining Additional Publications and Information

Information about Cisco products, technologies, and network solutions is available from various online and printed sources.

- Cisco Marketplace provides a variety of Cisco books, reference guides, and logo merchandise. Visit Cisco Marketplace, the company store, at this URL:

<http://www.cisco.com/go/marketplace/>

- *Cisco Press* publishes a wide range of general networking, training and certification titles. Both new and experienced users will benefit from these publications. For current Cisco Press titles and other information, go to Cisco Press at this URL:

<http://www.ciscopress.com>

- *Packet* magazine is the Cisco Systems technical user magazine for maximizing Internet and networking investments. Each quarter, Packet delivers coverage of the latest industry trends, technology breakthroughs, and Cisco products and solutions, as well as network deployment and troubleshooting tips, configuration examples, customer case studies, certification and training information, and links to scores of in-depth online resources. You can access Packet magazine at this URL:

<http://www.cisco.com/packet>

- *iQ Magazine* is the quarterly publication from Cisco Systems designed to help growing companies learn how they can use technology to increase revenue, streamline their business, and expand services. The publication identifies the challenges facing these companies and the technologies to help solve them, using real-world case studies and business strategies to help readers make sound technology investment decisions. You can access iQ Magazine at this URL:

<http://www.cisco.com/go/iqmagazine>

- *Internet Protocol Journal* is a quarterly journal published by Cisco Systems for engineering professionals involved in designing, developing, and operating public and private internets and intranets. You can access the Internet Protocol Journal at this URL:

<http://www.cisco.com/ipj>

- World-class networking training is available from Cisco. You can view current offerings at this URL:

<http://www.cisco.com/en/US/learning/index.html>



Installation and Configuration

This guide provides you with the information needed to mount AP1020 and AP1030 Cisco Aironet 1000 Series 802.11a/b/g lightweight access points. Cisco Aironet 1000 Series 802.11a/b/g lightweight access points are part of the innovative Cisco Wireless LAN Solution (Cisco WLAN Solution), and require no manual configuration after they are mounted.

This document is written assuming that you have already performed a site survey as described in the *Cisco Aironet 1000 Series IEEE 802.11a/b/g Lightweight Access Point Deployment Guide*, that Cisco Aironet 1000 Series lightweight access point locations and mounting options have been selected, and that you have one Cisco Aironet 1000 Series lightweight access point per indicated location.

After the site survey is done, you should have a map indicating the following:

- Cisco Aironet 1000 Series lightweight access point locations.
- Cisco Aironet 1000 Series lightweight access point mounting options: hanging from a ceiling, in the ceiling plenum, projecting away from the wall, flat against the wall, or using the Ceiling-Mount Bezel Kit.
- Cisco Aironet 1000 Series lightweight access point power options: power supplied by the AC-to-DC power supply orderable from the factory, or PoE from a network device or a PoE injector/hub (usually located in a wiring closet).



Caution

Plenum-mounted Cisco Aironet 1000 Series 802.11a/b/g lightweight access points **MUST BE** powered using PoE to comply with safety regulations.

If you do not have a map, make one so you can record the MAC addresses from each location and return them to the person who is planning or managing this wireless network.

Refer to the following sections to install the Cisco Aironet 1000 Series 802.11a/b/g lightweight access points.



Note

When mounting Cisco Aironet 1000 Series 802.11a/b/g lightweight access points, be sure to maintain a 20 cm (8 in.) separation between the Cisco Aironet 1000 Series 802.11a/b/g lightweight access points and bystanders to comply with FCC RF exposure regulations. Refer to the [“FCC Statements for Cisco Aironet 1000 Series Lightweight Access Points”](#) section for more information.

For more details about Cisco Aironet 1000 Series lightweight access point installations, refer to the [“Planning Notes”](#) section at the end of this document.

ATTENTION!

While Cisco Aironet 1000 Series IEEE 802.11a/b/g lightweight access points have been engineered for easy installation, there are some very important guidelines for installation:

- PLACE Cisco Aironet 1000 Series Lightweight Access Points **NO MORE THAN 140 FEET APART FROM EACH OTHER**. Placing Cisco Aironet 1000 Series 802.11a/b/g lightweight access points farther apart almost always results in poor coverage.
- **DO NOT MOUNT** Cisco Aironet 1000 Series Lightweight Access Points **OUTSIDE BUILDINGS**.
- **DO NOT MOUNT** Cisco Aironet 1000 Series Lightweight Access Points **ON BUILDING PERIMETER WALLS UNLESS THE OPERATOR WANTS TO PROVIDE COVERAGE OUTSIDE THE BUILDING**.
- BE SURE that plenum-mounted Cisco Aironet 1000 Series 802.11a/b/g lightweight access points are powered using Power over Ethernet (PoE) and use only the metal brackets (not the Ceiling-Mount Base or the Hanging-Ceiling Clips) to comply with safety regulations.
- BE SURE THAT Cisco Aironet 1000 Series Lightweight Access Points **ARE INSTALLED VERTICALLY** as shown in [Figure 1](#). Installing Cisco Aironet 1000 Series 802.11a/b/g lightweight access points vertically either standing up in a plenum or hanging from a ceiling, creates the largest coverage area per Cisco Aironet 1000 Series lightweight access point. Hanging Cisco Aironet 1000 Series 802.11a/b/g lightweight access points from the ceiling provides the best RF coverage.

Figure 1 Access Point Installed Vertically

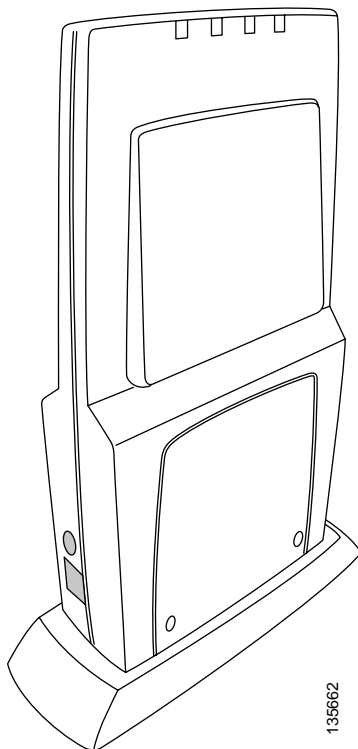

- **DO NOT MOUNT** Cisco Aironet 1000 Series lightweight access point **ANTENNAS WITHIN ONE METER (3 FT.) OF ANY METAL OBSTRUCTIONS**. THE RF WAVES FROM Cisco Aironet 1000 Series Lightweight Access Points **ARE BLOCKED AND/OR REFLECTED BY METAL OBJECTS**

such as metal HVAC ducts, conduit, pipes, bookcases, elevator shafts, stairwells, and metal walls. REFER TO THE *Cisco Aironet 1000 Series IEEE 802.11a/b/g Lightweight Access Point Deployment Guide* BEFORE MOUNTING Cisco Aironet 1000 Series Lightweight Access Points NEAR METAL OBSTRUCTIONS.

Figure 2 Access Point Clearance

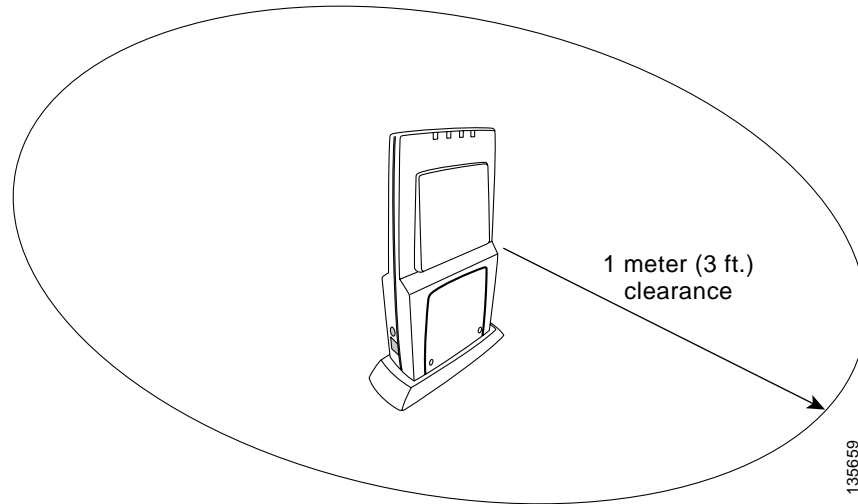

- WHEN MOUNTING Cisco Aironet 1000 Series Lightweight Access Points IN THE CORNER OF A RIGHT-ANGLE HALLWAY INTERSECTION, MOUNT THE Cisco Aironet 1000 Series Lightweight Access Point AT A 45-DEGREE ANGLE TO THE TWO HALLWAYS. The Cisco Aironet 1000 Series lightweight access point internal antennas are not omnidirectional and cover a larger area when mounted this way.

Figure 3 Mounting the Access Point in the Correct Direction

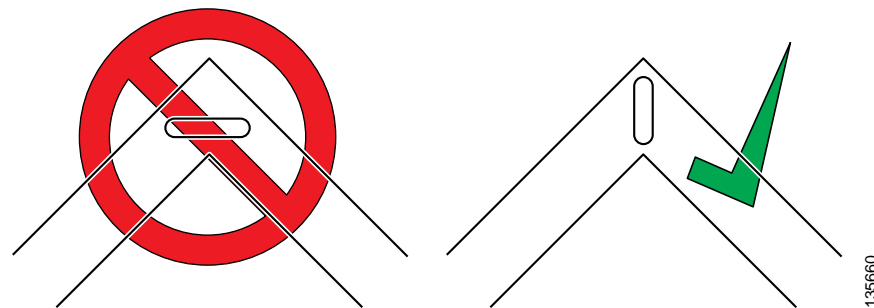

When a Cisco Aironet 1000 Series lightweight access point is configured with an IP address and is moved to a different IP segment, it attempts to join a Cisco Wireless LAN Controller. If it is unable to join a Cisco Wireless LAN Controller after a number of attempts, it does an arp for the default configured gateway. If the Cisco Aironet 1000 Series lightweight access point is on the wrong subnet, it will not be able to resolve the gateway arp and it will attempt to contact a DHCP server. This is the Cisco Aironet 1000 Series lightweight access point IP address fallback feature. However, if the destination IP segment does not have a DHCP server, the Cisco Aironet 1000 Series lightweight access point retains its original IP address and can never join the network.

Collecting Required Tools and Supplies

This section describes the tools and information that you should have before installing the access point.

- One Cisco Aironet 1000 Series lightweight access point per location.
- Cisco Aironet 1000 Series lightweight access point Mounting Kits, factory-supplied with each Cisco Aironet 1000 Series lightweight access point.
- Optional Cisco Aironet 1000 Series lightweight access point Mounting Kits, factory-orderable.
- Optional AC-to-DC external power supplies, factory-orderable. Note that this option requires the power cable to be run through the plenum in a metal conduit to meet safety requirements.
- Map showing Cisco Aironet 1000 Series lightweight access point locations and mounting and power options.
- Screwdrivers, drills, and ladder.
- An assortment of sheet metal and drywall screws and toggle bolts.
- CAT-5 (or higher) cables to connect the Cisco Aironet 1000 Series lightweight access point locations and other network devices.
- Optional Kensington MicroSaver Security Cable to secure each Cisco Aironet 1000 Series lightweight access point.

Continue with “[Pre-Installation Configuration](#).”

Pre-Installation Configuration

The following procedures are designed to ensure that your Cisco Aironet 1000 Series lightweight access point physical installation and that initial operation goes as expected. If you are unable to prepare your Cisco Aironet 1000 Series lightweight access point for deployment, this step also describes RMA (Return Material Authorization) procedures.

Perform the following procedure on each Cisco Aironet 1000 Series lightweight access point BEFORE deploying it in its final location.

- [Preparing a Version 3.0 Cisco Aironet 1000 Series Lightweight Access Point](#) OR
- [Alternate Method of Preparing a Version 3.0 Cisco Aironet 1000 Series Lightweight Access Point](#) for installation in a Version 3.0 deployment

If you are unable to perform the following procedure, refer to the “[Obtaining Technical Assistance](#)” section.

Preparing a Version 3.0 Cisco Aironet 1000 Series Lightweight Access Point

If your Cisco Aironet 1000 Series lightweight access point has Operating System 3.0 or a later version loaded on it, continue with this procedure.



Note

This procedure is written assuming that you are preparing a version 3.0 Cisco Aironet 1000 Series lightweight access point to operate with a Cisco Wireless LAN Controller.

Configuration Setup

Figure 4 Configuration Setup

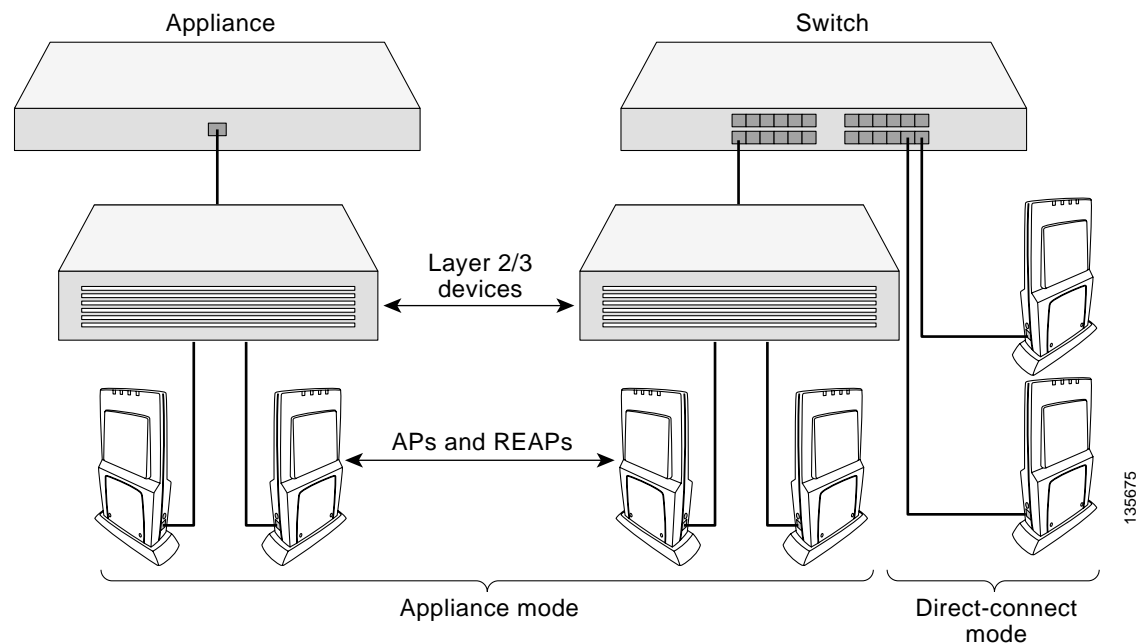

Does My Cisco Aironet 1000 Series Lightweight Access Point Qualify for this Procedure?

If your 3.0 or later version Cisco Aironet 1000 Series lightweight access point(s) cannot be configured for any reason using the following procedure, refer to the “[Obtaining Technical Assistance](#)” section.

Configuration Steps for a Cisco Aironet 1000 Series Lightweight Access Point

To configure an access point, perform these steps:

- Step 1** Configure the Cisco Wireless LAN Controller in **LWAPP Layer 3 Mode** and be sure its DS Port is connected to the network.



Note

When you are installing a Cisco 1030 remote edge lightweight access point, a DHCP server must be accessible by the access point.

- a. Be sure Cisco Aironet 1000 Series lightweight access point ports are available through the Cisco Wireless LAN Controller Management/AP-Manager Interface.
- b. Set the Cisco Wireless LAN Controller as the Master so that new Cisco Aironet 1000 Series 802.11a/b/g lightweight access points always associate with it. Use the CLI command *show network config* to determine if the Cisco Wireless LAN Controller DS Port is the Master. If the Cisco Wireless LAN Controller DS Port is not, make it the Master using the CLI command *config network master-base disable*.

- Step 2** Take the Cisco Aironet 1000 Series lightweight access point out of the box and plug it into the same subnet as the Cisco Wireless LAN Controller.

- Step 3** Apply power to the Cisco Aironet 1000 Series lightweight access point.

- a. Use 802.3af-compatible PoE from the Cisco Wireless LAN Controller or from an orderable inline power injector. If you do not have PoE available, use an orderable external AC-to-48 VDC Power Supply plugged into the side of the Cisco Aironet 1000 Series lightweight access point.



Note

Cisco Aironet 1000 Series 802.11a/b/g lightweight access points support 802.3af Power over Ethernet (PoE). These access points do not support Cisco prestandard PoE. Please use Cisco 802.3af capable PoE switches or power injectors.

- b. After you power up the Cisco Aironet 1000 Series lightweight access point, the RED Alarm LED comes on for about 15-20 seconds and then all the LEDs blink sequentially back and forth, indicating that the Cisco Aironet 1000 Series lightweight access point is trying to find a Cisco Wireless LAN Controller to associate with. This can continue for up to five minutes. If the Cisco Aironet 1000 Series lightweight access point remains in this mode for more than five minutes, the Cisco Aironet 1000 Series lightweight access point is unable to find the Master Cisco Wireless LAN Controller. Check the connection between the Cisco Aironet 1000 Series lightweight access point and the Cisco Wireless LAN Controller and be sure the Cisco Aironet 1000 Series lightweight access point and the Cisco Wireless LAN Controller are on the same subnet.
- c. If the power light does not come on, check the power (it can be powered either with PoE or from an orderable Cisco Aironet 1000 Series lightweight access point External Power Supply).
- d. Be sure that a DHCP server is configured in the Cisco Wireless LAN Controller for both the Management Interface and AP-Manager Interface using the CLI, Web User Interface, or Cisco WCS interface, and that the DHCP server is operating correctly.

- e. After the Cisco Aironet 1000 Series lightweight access point finds the Cisco Wireless LAN Controller, it attempts to download the new Operating System code if the Cisco Aironet 1000 Series lightweight access point code version differs from the Cisco Wireless LAN Controller code version. While this is happening, the LEDs on the top of the Cisco Aironet 1000 Series lightweight access point blink simultaneously.

Step 4 After the Operating System code download is successful, the Cisco Aironet 1000 Series lightweight access point reboots. The GREEN LED turns on and the two YELLOW LEDs indicate the states of the 802.11a and 802.11b/g networks. If any part of the network is disabled in the Cisco Wireless LAN Controller, the corresponding YELLOW LED remains off.

**Note**

The Red LED can light for about 10-20 seconds when the Cisco Aironet 1000 Series lightweight access point reboots. If the RED LED comes on AND STAYS ON for more than a minute, disconnect the Cisco Aironet 1000 Series lightweight access point and call Cisco Technical Assistance Center (TAC).

- Use the CLI command *show ap summary*. If the new Cisco Aironet 1000 Series lightweight access point appears on the list, it has been configured successfully.
- From the CLI, Web User Interface or Cisco WCS interface, configure the Cisco Aironet 1000 Series lightweight access point with its Primary, Secondary, and Tertiary Cisco Wireless LAN Controller names.
- If you will be using the Cisco Aironet 1000 Series lightweight access point in a Controller Mobility Group, set the Controller Mobility Group name using the CLI, Web User Interface or Cisco WCS interface.
- If required, use the CLI, Web User Interface or Cisco WCS interface to customize the Cisco Aironet 1000 Series lightweight access point-specific 802.11a, 802.11b and 802.11g network settings. Once again, the two YELLOW LEDs indicate the states of the 802.11a and 802.11b/g networks. If any part of the network is disabled, the corresponding YELLOW LED remains off.

Step 5 If everything works (the GREEN LED is on and the RED LED is off), disconnect the Cisco Aironet 1000 Series lightweight access point and take it to its final destination and install it as described later in this document. If your Cisco Aironet 1000 Series lightweight access point fails this visual test, refer to [“Obtaining Technical Assistance”](#) to return your Cisco Aironet 1000 Series lightweight access point.

**Note**

When you are installing a Cisco 1030 remote edge lightweight access point or a Layer 3 Cisco Aironet 1000 Series lightweight access point on a different subnet than the Cisco Wireless LAN Controller, BE SURE that a DHCP server is available on the subnet where you will be installing the Cisco Aironet 1000 Series lightweight access point, and that the subnet has a route back to the Cisco Wireless LAN Controller. Also be sure that the route back to the Cisco Wireless LAN Controller has destination UDP ports 12222 and 12223 open for LWAPP communications. Ensure the route back to the Primary, Secondary, and Tertiary Cisco Wireless LAN Controller allows IP packet fragments. Finally, be sure that if address translation is used, that the Cisco Aironet 1000 Series lightweight access point and the Cisco Wireless LAN Controller have a static 1-to-1 NAT to an outside address. (Port Address Translation is not supported.)

Step 6 When you have installed and powered up the Cisco Aironet 1000 Series lightweight access point in its final destination, verify that the LEDs are in the same state they were in at the end of Step 4.

- If no LEDs are on, the Cisco Aironet 1000 Series lightweight access point is most likely not receiving power.

- If the LEDs blink sequentially for more than five minutes, the Cisco Aironet 1000 Series lightweight access point is unable to find its Primary, Secondary, or Tertiary Cisco Wireless LAN Controller. Check the connection between the Cisco Aironet 1000 Series lightweight access point and the Cisco Wireless LAN Controller, and be sure the Cisco Aironet 1000 Series lightweight access point and the Cisco Wireless LAN Controller are either on the same subnet or that the Cisco Aironet 1000 Series lightweight access point has a route back to its Primary, Secondary, and Tertiary Cisco Wireless LAN Controller.
- If the Cisco Aironet 1000 Series lightweight access point is not on the same subnet as the Cisco Wireless LAN Controller, be sure there is a DHCP server on the same subnet as the Cisco Aironet 1000 Series lightweight access point. Also, be sure that the route between the Cisco Aironet 1000 Series lightweight access point and the Cisco Wireless LAN Controller can process IP fragmented packets.

Step 7 If no LEDs are on, the Cisco Aironet 1000 Series lightweight access point is most likely not receiving power. If all the LEDs blink sequentially for more than five minutes, the Cisco Aironet 1000 Series lightweight access point is unable to find its Primary, Secondary, and Tertiary Cisco Wireless LAN Controllers. Check the connection between the Cisco Aironet 1000 Series lightweight access point and the Cisco Wireless LAN Controller, and be sure that they are either on the same subnet or that the Cisco Aironet 1000 Series lightweight access point has a route back to its Primary, Secondary, and Tertiary Cisco Wireless LAN Controller. Note that the Cisco 1030 remote edge lightweight access points at each remote location must be on the same subnet to allow client roaming. Also, if the Cisco Aironet 1000 Series lightweight access point is not on the same subnet as the Cisco Wireless LAN Controller, be sure there is a DHCP server on the same subnet as the Cisco Aironet 1000 Series lightweight access point.

After you have prepared all Cisco Aironet 1000 Series 802.11a/b/g lightweight access points, reconfigure the Cisco Wireless LAN Controller so it is not the Master. A Master Cisco Wireless LAN Controller should only be used for configuring Cisco Aironet 1000 Series 802.11a/b/g lightweight access points and not in a working network. Note that the Master Cisco Wireless LAN Controller is normally not used in a deployed network, so the Master Cisco Wireless LAN Controller setting is automatically disabled upon reboot or OS code upgrade.

After completing “[Pre-Installation Configuration](#)” for all Cisco Aironet 1000 Series 802.11a/b/g lightweight access points, continue with “[Preparing Mounting Locations](#).”

Alternate Method of Preparing a Version 3.0 Cisco Aironet 1000 Series Lightweight Access Point

If your Cisco Aironet 1000 Series lightweight access point has Operating System 3.0 or later, you may choose to use this procedure.



Note

This procedure assumes that you are preparing a version 3.0 Cisco Aironet 1000 Series lightweight access point to operate with a version 3.0 Cisco Wireless LAN Controller. It also assumes that your Cisco Wireless LAN Controller is already operating in **LWAPP Layer 3 Mode**. It also assumes that you are using the Internet Software Consortium (ISC) DHCP Server V3.0p11. Finally, it assumes that if you have deployed multiple Cisco Wireless LAN Controllers, the Cisco Wireless LAN Controller you use to initialize the Cisco Aironet 1000 Series lightweight access point is in an existing *Controller Mobility Group* with the *Primary, Secondary, and Tertiary Cisco Wireless LAN Controllers* you want to assign to the new Cisco Aironet 1000 Series lightweight access point.

Configuration Setup

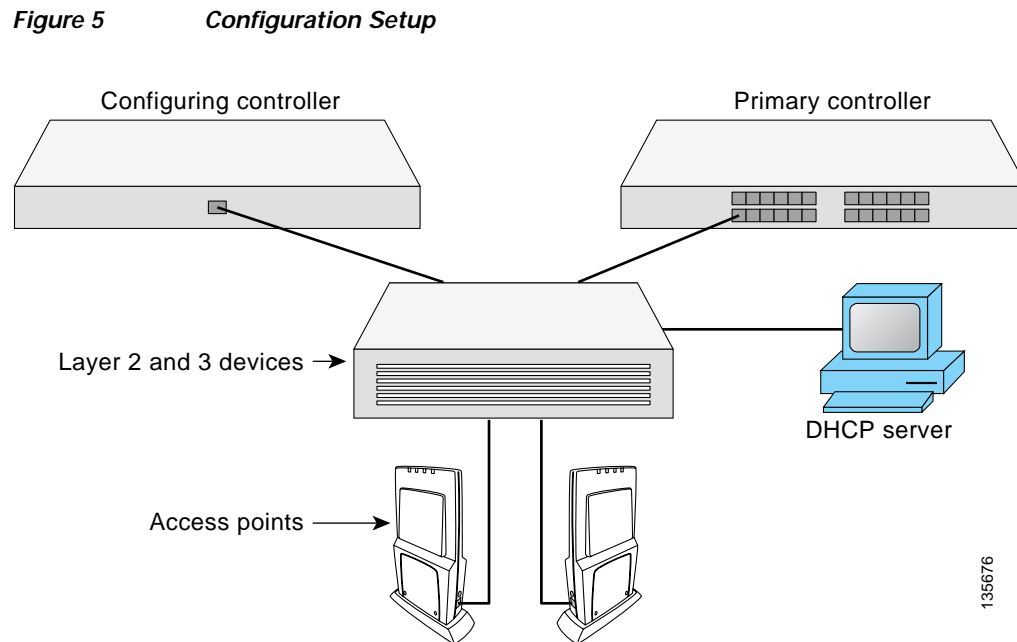

135676

Does My Cisco Aironet 1000 Series Lightweight Access Point Qualify for this Procedure?

- If your 3.0 or later version Cisco Aironet 1000 Series lightweight access point(s) cannot be configured for any reason using the following procedure, refer to the “[Obtaining Technical Assistance](#)” section.

Configuration Steps for a Cisco 1000 Series Lightweight Access Point

1. Configure the Internet Software Consortium (ISC) V3.0p11 DHCP Server to provide the vendor-specific Option 43 using the following entries:

```
option controller code 43 = text;
option controller "<Switch IP Address>";
```

in which **<Switch IP Address>** is the IP address of the Cisco Wireless LAN Controller you are going to use to prepare the Cisco Aironet 1000 Series lightweight access point, or which can be a comma-delimited string of Cisco Wireless LAN Controller IP addresses.

(These commands direct all discovery messages for unconfigured Cisco Aironet 1000 Series 802.11a/b/g lightweight access points to the configuring Cisco Wireless LAN Controller.)

2. Be sure the configuring Cisco Wireless LAN Controller is in **LWAPP Layer 3 Mode** (use the CLI command **show switchconfig** to determine the mode; if it is set to Layer 3, use the CLI command **config switchconfig mode L2** to change it to Layer 2). Be sure that the configuring Cisco Wireless LAN Controller is in the same Controller Mobility Group as the planned *Primary, Secondary, and Tertiary Cisco Wireless LAN Controllers*, and that the configuring Cisco Wireless LAN Controller DS Port is connected to the network.

3. Also be sure that the DHCP server is configured in the Cisco Wireless LAN Controller for both the Management Interface and AP-Manager Interface using the CLI, Web User Interface, or Cisco WCS user interface.

**Note**

When you are installing a Cisco Aironet 1000 Series lightweight access point, a DHCP server must be accessible by the Cisco Aironet 1000 Series lightweight access point.

4. Take the Cisco Aironet 1000 Series lightweight access point out of the box and plug it into the network so that it can request an IP address from the DHCP server.
5. Apply power to the Cisco Aironet 1000 Series lightweight access point:
 - a. Use 802.3af-compatible PoE from the network equipment or from an orderable inline power injector. If you do not have PoE available, use an orderable AC-to-48 VDC External Power Supply plugged into the side of the Cisco Aironet 1000 Series lightweight access point.

**Note**

Cisco Aironet 1000 Series 802.11a/b/g lightweight access points support 802.3af Power over Ethernet (PoE). These access points do not support Cisco prestandard PoE. Please use Cisco 802.3af capable PoE switches or power injectors

- b. After you power up the Cisco Aironet 1000 Series lightweight access point, the RED Alarm LED comes on for about 15-20 seconds and then all the LEDs blink sequentially back and forth, indicating that the Cisco Aironet 1000 Series lightweight access point is trying to find a Cisco Wireless LAN Controller to connect to. This can continue for up to five minutes. If the Cisco Aironet 1000 Series lightweight access point remains in this mode for more than five minutes, the Cisco Aironet 1000 Series lightweight access point is unable to find the Master Cisco Wireless LAN Controller. Check the connection between the Cisco Aironet 1000 Series lightweight access point and the Cisco Wireless LAN Controller and be sure that they are on the same subnet.
 - c. If the power light does not come on, check the power (it can be powered either with PoE or a from an orderable Cisco Aironet 1000 Series lightweight access point External Power Supply).
6. The Cisco Aironet 1000 Series lightweight access point requests an IP address from the DHCP server, and the DHCP server returns an IP address for the Cisco Aironet 1000 Series lightweight access point, and also returns the IP Address of the configuring Cisco Wireless LAN Controller.

After the Cisco Aironet 1000 Series lightweight access point finds the configuring Cisco Wireless LAN Controller, it attempts to download the new Operating System code if the Cisco Aironet 1000 Series lightweight access point code version differs from the configuring Cisco Wireless LAN Controller code version. While this is happening, the LEDs on the top of the Cisco Aironet 1000 Series lightweight access point blink simultaneously.
7. After the Operating System code is downloaded, the Cisco Aironet 1000 Series lightweight access point reboots. The GREEN LED turns on and the two YELLOW LEDs indicate the states of the 802.11a and 802.11b/g networks. If any part of the network is disabled in the configuring Cisco Wireless LAN Controller, the corresponding YELLOW LED remains off.
 - Note that the Red LED can light for about 10-20 seconds when the Cisco Aironet 1000 Series lightweight access point reboots. If the RED LED comes on AND STAYS ON for more than a minute, disconnect the Cisco Aironet 1000 Series lightweight access point and call Cisco Technical Assistance Center (TAC).

- From the CLI, Web User Interface or Cisco WCS interface, configure the Cisco Aironet 1000 Series lightweight access point with its Primary, Secondary, and Tertiary Cisco Wireless LAN Controller names (any of which can be the name of the configuring Cisco Wireless LAN Controllers).
 - If required, use the CLI, Web User Interface or Cisco WCS interface to customize the Cisco Aironet 1000 Series lightweight access point-specific 802.11a, 802.11b and 802.11g network settings. Once again, the two YELLOW LEDs indicate the states of the 802.11a and 802.11b/g networks. If any part of the network is disabled, the corresponding YELLOW LED remains off.
8. If everything works (the GREEN LED is on and the RED LED is off), reboot the Cisco Aironet 1000 Series lightweight access point and install it as described in this document. If your Cisco Aironet 1000 Series lightweight access point fails this visual test, refer to the [“Obtaining Technical Assistance”](#) section to return your Cisco Aironet 1000 Series 802.11a/b/g lightweight access points.

**Note**

When you are installing a Cisco 1030 remote edge lightweight access point or a Layer 3 Cisco Aironet 1000 Series lightweight access point on a different subnet than the Cisco Wireless LAN Controller, BE SURE that a DHCP server is available on the subnet where you will be installing the Cisco Aironet 1000 Series lightweight access point and that the subnet has a route back to the Primary, Secondary, and Tertiary Cisco Wireless LAN Controller. Ensure that the route back to the Cisco Wireless LAN Controller has destination UDP ports 12222 and 12223 open for LWAPP communications. Ensure the route back to the Primary, Secondary, and Tertiary Cisco Wireless LAN Controller allows IP packet fragments. Finally, be sure that if address translation is used, the Cisco Aironet 1000 Series lightweight access point and the Cisco Wireless LAN Controller have a static 1-to-1 NAT to an outside address. (Port Address Translation is not supported.)

9. When you have installed and powered up the Cisco Aironet 1000 Series lightweight access point in its final destination, verify that the LEDs are in the same state they were in at the end of Step 7.
- If no LEDs are on, the Cisco Aironet 1000 Series lightweight access point is most likely not receiving power.
 - If the LEDs blink sequentially for more than five minutes, the Cisco Aironet 1000 Series lightweight access point is unable to find its Primary, Secondary, or Tertiary Cisco Wireless LAN Controller. Check the connection between the Cisco Aironet 1000 Series lightweight access point and the Cisco Wireless LAN Controller, and be sure that they are either on the same subnet or that the Cisco Aironet 1000 Series lightweight access point has a route back to its Primary, Secondary, and Tertiary Cisco Wireless LAN Controllers.
 - Note that the Cisco 1030 remote edge lightweight access points at each remote location must be on the same subnet to allow client roaming. Also, if the Cisco Aironet 1000 Series lightweight access point is not on the same subnet as the Cisco Wireless LAN Controller, be sure that a DHCP server is accessible on the same subnet as the Cisco Aironet 1000 Series lightweight access point.

After completing [“Pre-Installation Configuration”](#) for all Cisco Aironet 1000 Series 802.11a/b/g lightweight access points, continue with [“Preparing Mounting Locations.”](#)

Preparing Mounting Locations

On your map, you should have the Cisco Aironet 1000 Series lightweight access point locations, mounting options, and power options.



Note

BE SURE that plenum-mounted Cisco Aironet 1000 Series 802.11a/b/g lightweight access points use only the metal Projection-Mount and Flush-Mount brackets (not the Ceiling-Mount Base or the Hanging-Ceiling Clips) and are powered using PoE to comply with safety regulations. Also, external antennas are NOT to be used when installing Cisco Aironet 1000 Series 802.11a/b/g lightweight access points in a plenum.

1. Find the required mounting locations.
 - Use the ceiling-mount base to mark the wall or ceiling locations for sheet metal, drywall, or other screws. Be sure to leave enough space around the Cisco Aironet 1000 Series lightweight access point and base to plug the CAT-5 cable, optional external antenna cable(s), optional power supply cable, and optional Kensington MicroSaver Security Cable into the sides of the Cisco Aironet 1000 Series lightweight access point.

Figure 6 **Factory-Supplied Mounting Options**

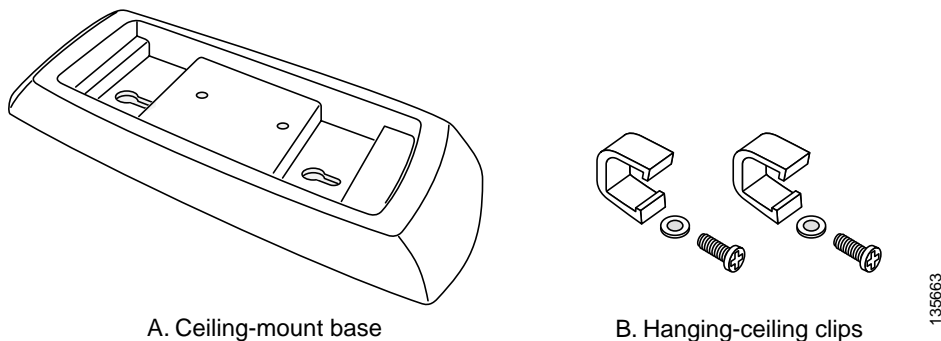

- Alternatively, attach the hanging ceiling clips to the Cisco Aironet 1000 Series lightweight access point. Be sure you leave enough space around the Cisco Aironet 1000 Series lightweight access point to plug the CAT-5 cable, optional external antenna cable(s), optional power supply cable, and optional Kensington MicroSaver Security Cable into the sides of the Cisco Aironet 1000 Series lightweight access point.
- Alternatively, use the optional mounting bases or brackets to mark the wall or ceiling locations for sheet metal, drywall, or other screws. Be sure to leave enough space around the Cisco Aironet 1000 Series lightweight access point and brackets to plug the CAT-5 cable, optional external antenna cable(s), optional power supply cable, and optional Kensington MicroSaver Security Cable into the sides of the Cisco Aironet 1000 Series lightweight access point.

Figure 7 **Factory-Orderable Mounting Brackets**

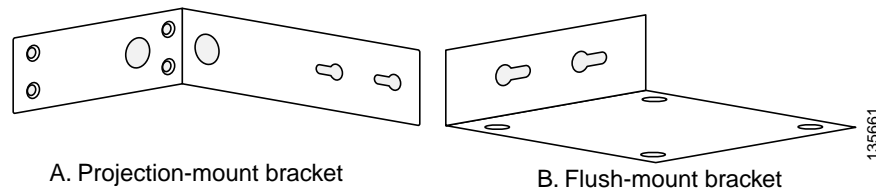

2. If necessary, drill holes for the various cables where they can be mostly hidden from casual view. When you are mounting the Cisco Aironet 1000 Series lightweight access point using an optional orderable projection-mount L-bracket (the one with two long legs), the cables can be routed through the 5/8-in. (15.9 mm) holes in the bracket.
3. Route the CAT-5, optional power supply, optional external antenna cable(s), and optional Kensington MicroSaver Security cables to where they can plug into the Cisco Aironet 1000 Series lightweight access point. Be sure to leave about 6 in. (15 cm) of slack in the cables for future modifications.
4. Attach the brackets to the wall or ceiling, or install screws for ceiling-mount base:
 - Where you are going to use the projection-mount or flush-mount bracket, use customer-supplied sheet metal, drywall, or other screws to attach the bracket to the ceiling or wall.
 - Where you are going to use the ceiling-mount base, install customer-supplied sheet metal, drywall, or other screws with 1/4 in. (6.35 mm) or smaller heads protruding from the ceiling about 0.1 in. (2.5 mm).

You are now ready to install the Cisco Aironet 1000 Series 802.11a/b/g lightweight access points. Continue with [“Mounting the Cisco Aironet 1000 Series Lightweight Access Points.”](#)

Mounting the Cisco Aironet 1000 Series Lightweight Access Points

Using the supplied or optional orderable Cisco Aironet 1000 Series lightweight access point mounting kits, mount each Cisco Aironet 1000 Series lightweight access point in its indicated location, oriented as shown on the map. Note that you can mount the Cisco Aironet 1000 Series 802.11a/b/g lightweight access points in the ceiling plenum or below the ceiling, but that they perform best when mounted below the ceiling.

**Note**

The Cisco Aironet 1000 Series lightweight access point supports Antenna Sectorization, which can be used to increase the number of clients and client throughput in a given air space. Installers can mount two Cisco Aironet 1000 Series 802.11a/b/g lightweight access points back-to-back and the Network operator can disable the second antenna in both Cisco Aironet 1000 Series 802.11a/b/g lightweight access points to create a 360-degree coverage area with two sectors.

The Cisco Aironet 1000 Series 802.11a/b/g lightweight access points can be mounted in one of the following configurations:

- Ceiling-Mount Base -- Refer to [Ceiling Mount Base](#).
- Ceiling-Mount Clips -- Refer to [Ceiling-Mount Clips](#).
- Projection Wall Mount -- Refer to [Projection Wall Mount](#).
- Flush Wall Mount -- Refer to [Flush Wall Mount](#).
- Ceiling-Mount Bezel -- Refer to the *Cisco Aironet 1000 Series Lightweight Access Point Ceiling-Mount Bezel Kit Installation and Configuration Guide*.

Ceiling Mount Base

When you are mounting the Cisco Aironet 1000 Series lightweight access point in the middle of a ceiling (flat sides toward the room or hallway), use the ceiling-mount base to mount the Cisco Aironet 1000 Series lightweight access point as shown in the following figure and as described below:

Figure 8 Attaching the Cisco Aironet 1000 Series Lightweight Access Point and Ceiling-Mount Base

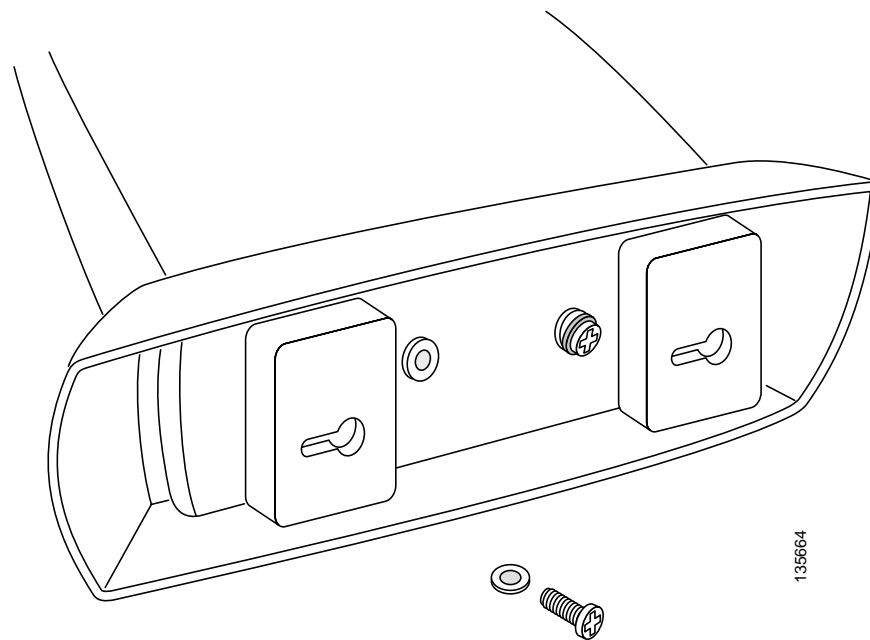

1. Copy the MAC address(es) from the label(s) on the Cisco Aironet 1000 Series lightweight access point onto the corresponding location on the map. MAC addresses have the format 00xxxxxxxxxx.
2. Attach the ceiling-mount base to the bottom of the Cisco Aironet 1000 Series lightweight access point using the factory-supplied machine screws and washers.
3. Position the ceiling-mount base so its keyhole slots are partly on the drywall, sheet metal, or other screw heads installed in [“Preparing Mounting Locations.”](#)



Note

If the screws do not securely hold the ceiling-mount base, remove the Cisco Aironet 1000 Series lightweight access point and adjust the screws until they hold the ceiling-mount base securely.

4. Attach the cables to the sides of the Cisco Aironet 1000 Series lightweight access point.



Note

When the Cisco Aironet 1000 Series lightweight access point is powered up and is associated with a Cisco Wireless LAN Controller (Green/Power and Yellow/802.11b/g and/or Yellow or Amber/802.11a LEDs lit), the Cisco Aironet 1000 Series lightweight access point is broadcasting its beacon signal(s). When this happens, complete the installation as quickly as possible to remove yourself from within 8 in. (20 cm) of the Cisco Aironet 1000 Series lightweight access point to comply with FCC RF radiation exposure guidelines.

5. Slide the ceiling-mount base onto the drywall, sheet metal, or other screw heads until it fits snugly in place.

You installed the access point. Repeat [“Mounting the Cisco Aironet 1000 Series Lightweight Access Points”](#) for each location, and then continue with [“Returning MAC Information.”](#)

Ceiling-Mount Clips

When you are mounting the Cisco Aironet 1000 Series lightweight access point on the extruded aluminium rails of a hanging ceiling, use the ceiling-mount clips to mount the Cisco Aironet 1000 Series lightweight access point as shown in the following figure and as described below:

Figure 9 *Assembling the Cisco Aironet 1000 Series Lightweight Access Point and Ceiling-Mount Clips*

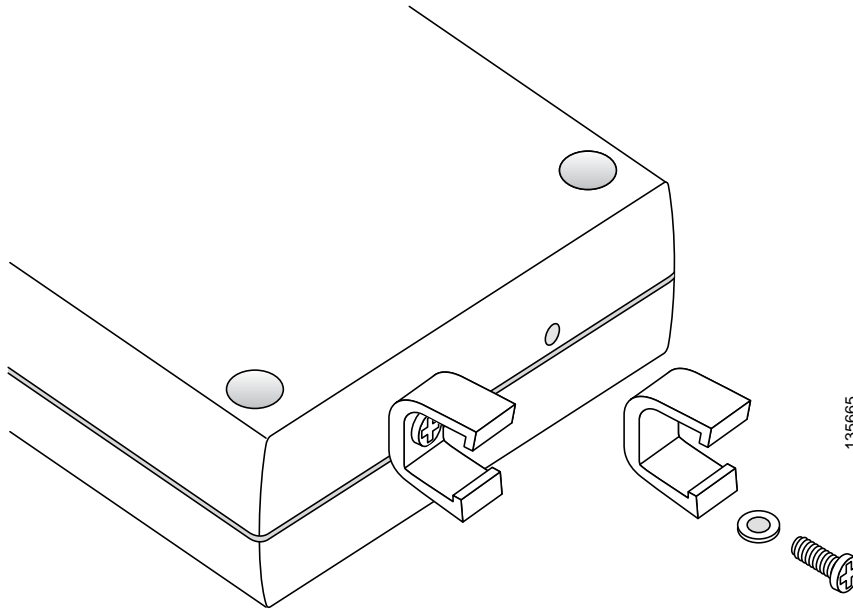

1. Copy the MAC address(es) from the label(s) on the Cisco Aironet 1000 Series lightweight access point onto the corresponding location on the map. MAC addresses have the format 00xxxxxxxxxx.
2. Attach the ceiling-mount clips to the bottom of the Cisco Aironet 1000 Series lightweight access point using the factory-supplied machine screws and washers.
3. Snap the ceiling-mount clips onto a hanging ceiling rail.

Figure 10 *Clipping the Cisco Aironet 1000 Series Lightweight Access Point and Ceiling-Mount Clips to a Hanging-Ceiling Rail*

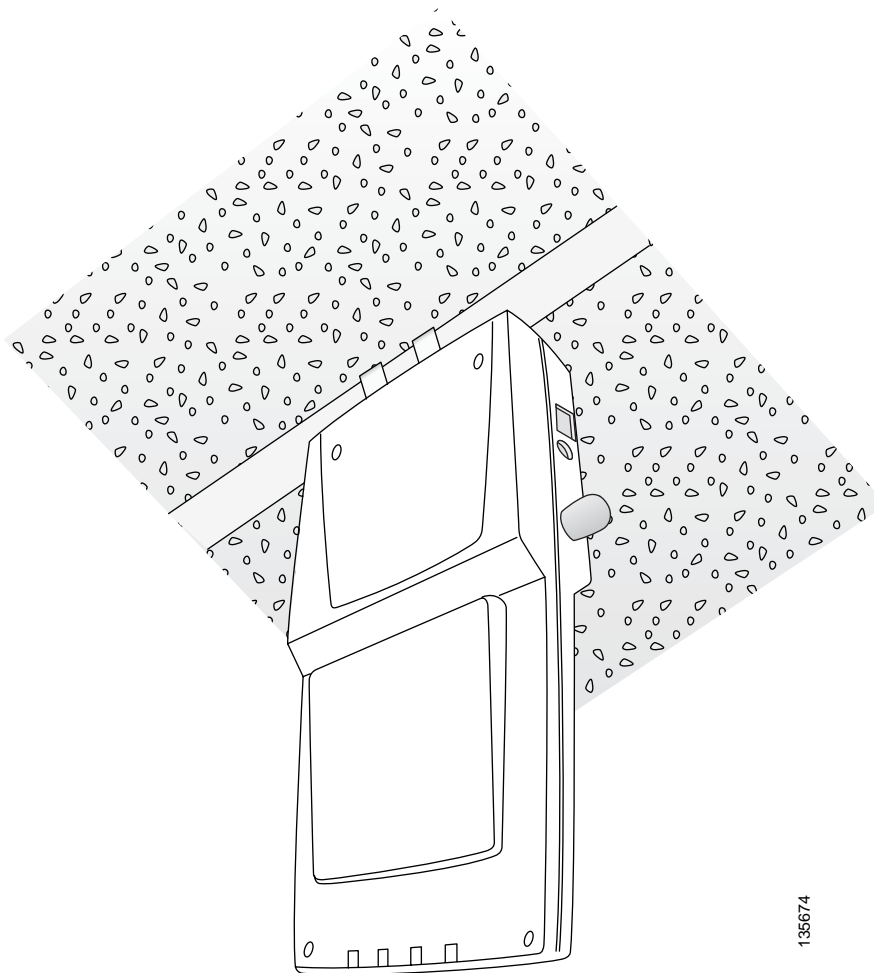

4. Attach the cables to the sides of the Cisco Aironet 1000 Series lightweight access point.



Note

- Be sure the cables are routed away from the Cisco Aironet 1000 Series lightweight access point antennas.
- When the Cisco Aironet 1000 Series lightweight access point is powered up and is associated with a Cisco Wireless LAN Controller (Green/Power and Yellow/802.11b/g and/or Yellow or Amber/802.11a LEDs lit), the Cisco Aironet 1000 Series lightweight access point is broadcasting its beacon signal(s). When this happens, complete the installation as quickly as possible to remove yourself from within 8 in. (20 cm) of the Cisco Aironet 1000 Series lightweight access point to comply with FCC RF radiation exposure guidelines.

You have installed the Cisco Aironet 1000 Series lightweight access point. Repeat “[Mounting the Cisco Aironet 1000 Series Lightweight Access Points](#)” for each Cisco Aironet 1000 Series lightweight access point location, and then continue with “[Returning MAC Information](#).”

Projection Wall Mount

When you are mounting the Cisco Aironet 1000 Series lightweight access point out from a wall (flat sides along the wall or hallway), use an optional separately orderable factory-orderable projection-mount L-bracket.

1. Before proceeding, gently screw the two factory-supplied screws and spring washers into the bottom of the Cisco Aironet 1000 Series lightweight access point. Be sure the spring washers have their convex (high center sections) pointing toward the screw heads.



Note

The Cisco Aironet 1000 Series lightweight access point threaded holes have precision-depth threads. Do not overtighten the screws, or the bracket will not fit under the screw heads.

Figure 11 *Attaching the Mounting Screws and Spring Washers to the Cisco Aironet 1000 Series Lightweight Access Point*

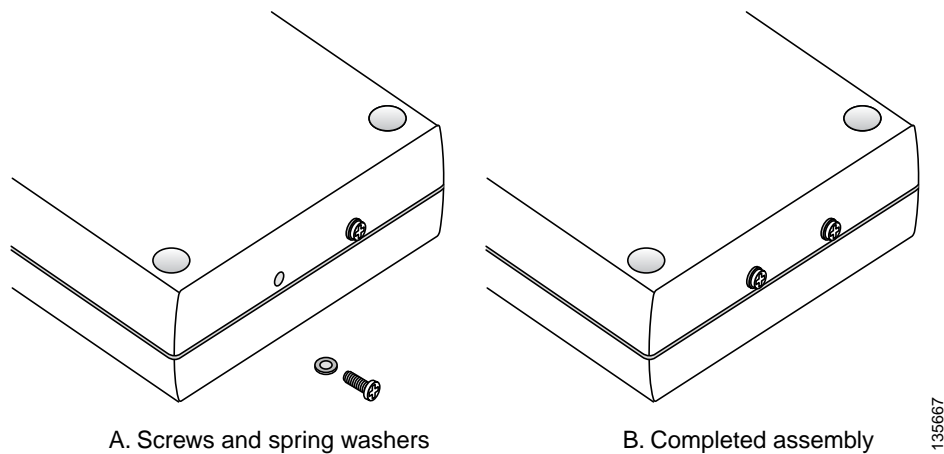

2. Copy the MAC address(es) from the label(s) on the Cisco Aironet 1000 Series lightweight access point onto the corresponding location on the map. MAC addresses have the format 00xxxxxxxx.
3. You have already attached the projection-mount L-bracket to the wall in “[Preparing Mounting Locations](#).”
4. Slide the screws into the keyhole slots on the mounting bracket as shown in the following figure.



Note

If the screws do not securely hold the bracket, remove the Cisco Aironet 1000 Series lightweight access point and adjust the screws until they securely hold the bracket.

Figure 12 *Attaching the Cisco Aironet 1000 Series Lightweight Access Point to the Projection-Mount Bracket*

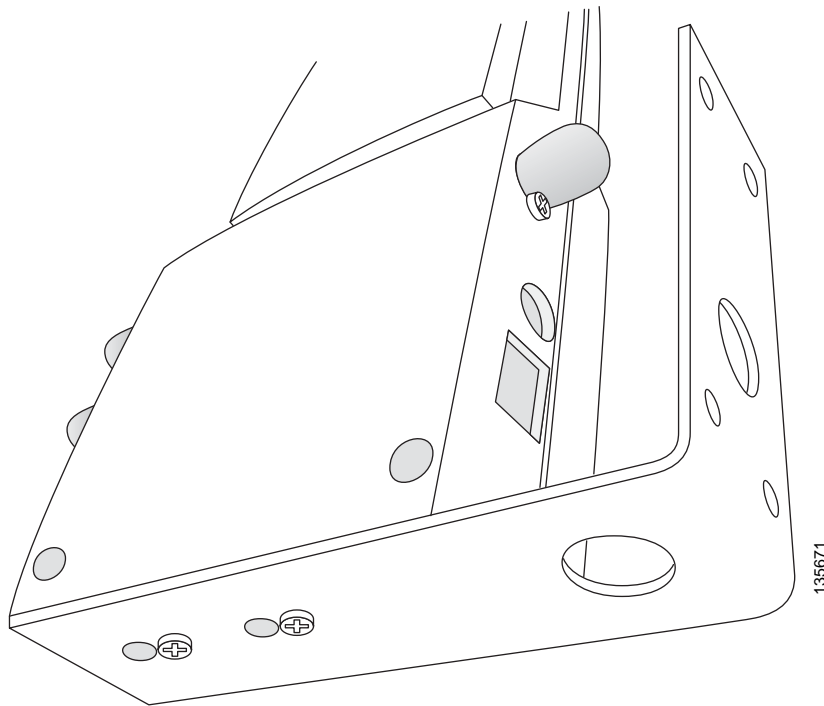

5. Attach the cables to the sides of the Cisco Aironet 1000 Series lightweight access point.

**Note**

- Be sure the cables are routed away from the Cisco Aironet 1000 Series lightweight access point antennas.
- When the Cisco Aironet 1000 Series lightweight access point is powered up and is associated with a Cisco Wireless LAN Controller (Green/Power and Yellow/802.11b/g and/or Yellow or Amber/802.11a LEDs lit), the Cisco Aironet 1000 Series lightweight access point begins broadcasting its beacon signal(s). When this happens, complete the installation as quickly as possible to remove yourself from within 8 in. (20 cm) of the Cisco Aironet 1000 Series lightweight access point to comply with FCC RF radiation exposure guidelines.

You have installed the Cisco Aironet 1000 Series lightweight access point. Repeat “[Mounting the Cisco Aironet 1000 Series Lightweight Access Points](#)” for each Cisco Aironet 1000 Series lightweight access point location, and then continue with “[Returning MAC Information](#).”

Flush Wall Mount

When you are mounting the Cisco Aironet 1000 Series lightweight access point against a wall (flat side toward the inside of the building), use an optional separately orderable factory-orderable flush-mount bracket.

1. Before proceeding, gently screw the two factory-supplied screws and spring washers into the bottom of the Cisco Aironet 1000 Series lightweight access point. Be sure the spring washers have their convex (high center sections) pointing toward the screw heads.



Note

The Cisco Aironet 1000 Series lightweight access point threaded holes have precision-depth threads. Do not overtighten the screws, or the bracket will not fit under the screw heads.

Figure 13 Attaching the Mounting Screws and Spring Washers to the Cisco Aironet 1000 Series Lightweight Access Point

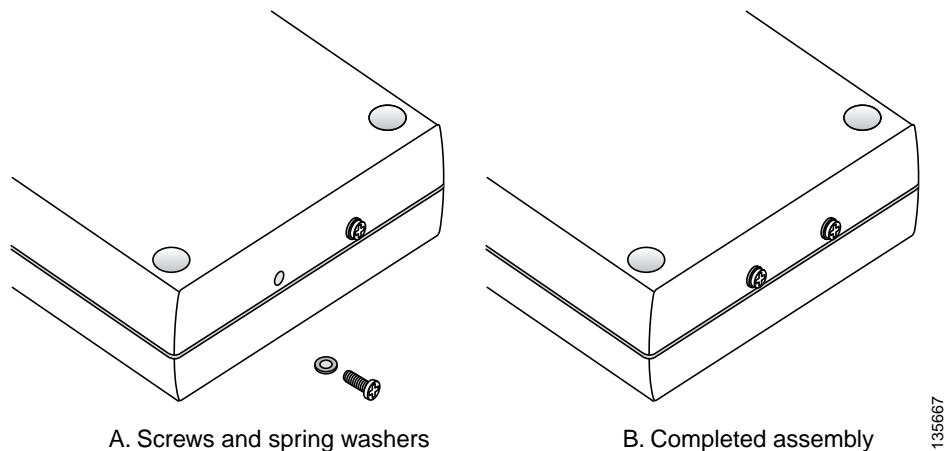

2. Copy the MAC address(es) from the label(s) on the Cisco Aironet 1000 Series lightweight access point onto the corresponding location on the map. MAC addresses have the format 00xxxxxxxx.
3. You have already attached the flush-mount bracket to the wall in “[Preparing Mounting Locations.](#)”
4. Slide the screws into the keyhole slots on the mounting bracket as shown in the following figure.



Note

- Be sure the side of the Cisco Aironet 1000 Series lightweight access point with the door is facing away from the wall. This ensures that the correct antenna is facing the building, and makes future upgrades easier.
- If the screws do not securely hold the bracket, remove the Cisco Aironet 1000 Series lightweight access point and adjust the screws until they securely hold the bracket.

Figure 14 **Attaching the Cisco Aironet 1000 Series Lightweight Access Point to the Flush-Mount Bracket**

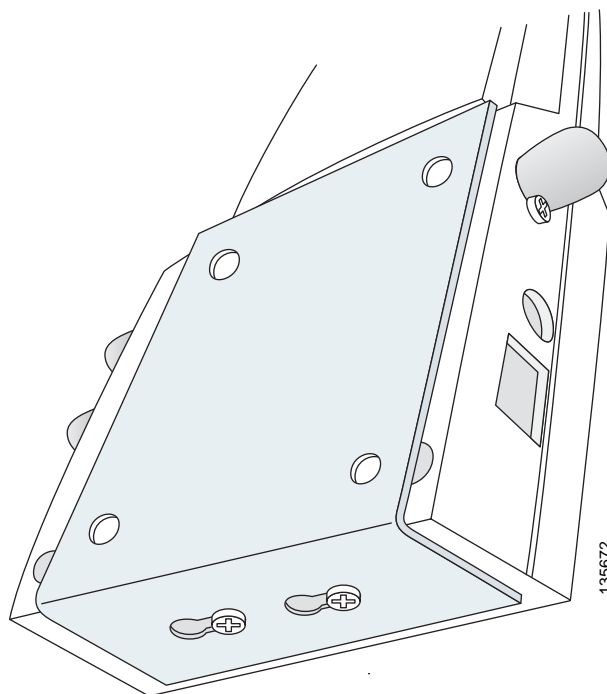

5. Attach the cables to the sides of the Cisco Aironet 1000 Series lightweight access point.



Note

- Be sure the cables are routed away from the Cisco Aironet 1000 Series lightweight access point antennas.
- When the Cisco Aironet 1000 Series lightweight access point is powered up and is associated with a Cisco Wireless LAN Controller (Green/Power and Yellow/802.11b/g and/or Yellow or Amber/802.11a LEDs lit), the Cisco Aironet 1000 Series lightweight access point begins broadcasting its beacon signal(s). When this happens, complete the installation as quickly as possible to remove yourself from within 8 in. (20 cm) of the Cisco Aironet 1000 Series lightweight access point to comply with FCC RF radiation exposure guidelines.

You have installed the Cisco Aironet 1000 Series lightweight access point. Repeat “[Mounting the Cisco Aironet 1000 Series Lightweight Access Points](#)” for each Cisco Aironet 1000 Series lightweight access point location, and then continue with “[Returning MAC Information](#).”

Returning MAC Information

When you have completed the installations as outlined in “[Mounting the Cisco Aironet 1000 Series Lightweight Access Points](#),” return the MAC addresses and their locations on the maps or floor plans to the network planner or manager. The Network operators will use the MAC address and location information to create maps for precise wireless Operating System management.

Also return any unused mounting kit hardware and external power supplies to the network planner or manager for use in future deployments.



Note

Please remind the Network Planner or Manager that now is a good time to register the Cisco Aironet 1000 Series 802.11a/b/g lightweight access points.



Planning Notes

- [About Cables](#)
- [About External Antennas](#)
- [About Mounting Options](#)
- [About Physical Security](#)
- [FCC Statements for Cisco Aironet 1000 Series Lightweight Access Points](#)
- [Safety Considerations](#)

About Cables

- You will run one CAT-5 Ethernet cable from the Cisco Aironet 1000 Series lightweight access point to a network device or a PoE injector/hub.
- When a Cisco 1000 Series lightweight access point will be mounted below the ceiling using the ceiling mount or wall mount brackets, you may have to drill a hole into the ceiling plenum to run the CAT-5 cable to the wiring closet. When the CAT-5 cable cannot be run through the ceiling plenum, find another path to route the cable from the Cisco Aironet 1000 Series lightweight access point to the wiring closet.
- When the Cisco Aironet 1000 Series lightweight access point will be mounted above the ceiling using the ceiling mount or wall mount brackets, run the CAT-5 cable to the wiring closet through the ceiling plenum. When the CAT-5 cable cannot be run through the ceiling plenum, find another path to route the cable from the Cisco Aironet 1000 Series lightweight access point to the wiring closet.
- When you are powering the Cisco Aironet 1000 Series lightweight access point from AC power, route the power supply cable from the AC electrical outlet to the Cisco Aironet 1000 Series lightweight access point. Be sure you secure the AC power plug so it will be difficult for people to pull on the power cord or unplug the power supply from the AC power outlet.
- When you are powering the Cisco Aironet 1000 Series lightweight access point from a PoE source (a network device, or a PoE injector/hub), you do not need to route a separate power cable to the Cisco Aironet 1000 Series lightweight access point, because the Cisco Aironet 1000 Series lightweight access point will receive its power across the CAT-5 Ethernet cable. Return the power supply to the wireless network planner/manager.

About External Antennas



Note

As described in the [AP1010 Cisco Aironet 1000 Series IEEE 802.11a/b/g Lightweight Access Point Installation and Configuration Guide](#), the AP1010 Cisco Aironet 1000 Series 802.11a/b/g lightweight access points are designed to be used exclusively with the internal high-gain antennas and have no jacks for external antennas.



Caution

External antennas are NOT to be used when installing Cisco Aironet 1000 Series 802.11a/b/g lightweight access points in a plenum.

- When you are attaching external antennas to the AP1020 and AP1030 Cisco Aironet 1000 Series lightweight access point, use cables with female reverse-TNC connectors to connect antennas to the ports on the side of the Cisco Aironet 1000 Series lightweight access point. See the following figure for antenna port markings.

Figure A-1 Cisco Aironet 1000 Series 802.11a/b/g Lightweight Access Point External Antenna Port Markings



A. 2.4 GHz/802.11b Left External Antenna Port



B. 5 GHz/802.11a and 2.4 GHz/802.11b Right External Antenna Ports

03032008

About Mounting Options



Caution

Plenum-mounted Cisco Aironet 1000 Series 802.11a/b/g lightweight access points **MUST BE** powered using PoE to comply with safety regulations.



Note

- Because the Cisco Aironet 1000 Series lightweight access point internal antennas have been designed to reduce inter-floor interference, it is strongly recommended that you mount the Cisco Aironet 1000 Series lightweight access point standing or hanging straight up or down.
 - You can mount the Cisco Aironet 1000 Series 802.11a/b/g lightweight access points in the ceiling plenum or below the ceiling using the ceiling mount base or wall mount brackets, but the Cisco Aironet 1000 Series 802.11a/b/g lightweight access points perform best when mounted below the ceiling.
 - External antennas are **NOT** to be used when installing Cisco Aironet 1000 Series 802.11a/b/g lightweight access points in a plenum.
-
- When you are mounting the Cisco Aironet 1000 Series lightweight access point in the middle of a ceiling, ceiling plenum, or hallway, you will typically use the color-coordinated ceiling-mount base to stabilize the Cisco Aironet 1000 Series lightweight access point after it is mounted. Use the mounting base to mark the sheet metal, drywall, or other screw locations.
The mounting base attaches to the bottom of the Cisco Aironet 1000 Series lightweight access point with two supplied screws, and then the assembly slides and locks onto two sheet metal, drywall, or other screws.
 - When you are mounting the Cisco Aironet 1000 Series lightweight access point out from a wall (flat sides along the room or hallway), use the projection-mount L-bracket supplied with the Cisco Aironet 1000 Series lightweight access point. Use the L-bracket to mark the sheet metal, drywall, or other screw locations.
 - When you are mounting the Cisco Aironet 1000 Series lightweight access point against a wall (flat Side A toward the inside of the building), use the flush-mount bracket supplied with the Cisco Aironet 1000 Series lightweight access point. The flush-mount L-bracket is the one with one long and one short leg. Use the L-bracket to mark the sheet metal, drywall, or other screw locations.

About Mounting Options



Note

- Because the Cisco Aironet 1000 Series lightweight access point internal antennas have been designed to reduce inter-floor interference, it is strongly recommended that you mount the Cisco Aironet 1000 Series lightweight access point standing or hanging straight up or down.
- You can mount the Cisco Aironet 1000 Series 802.11a/b/g lightweight access points in the ceiling plenum or below the ceiling using the ceiling mount base or wall mount brackets, but the Cisco Aironet 1000 Series 802.11a/b/g lightweight access points perform best when mounted below the ceiling.

**Caution**

Plenum-mounted Cisco Aironet 1000 Series 802.11a/b/g lightweight access points **MUST BE** powered using PoE to comply with safety regulations.

- When you are mounting the Cisco Aironet 1000 Series lightweight access point in the middle of a ceiling, ceiling plenum, or hallway, you will typically use the color-coordinated ceiling-mount base to stabilize the Cisco Aironet 1000 Series lightweight access point after it is mounted. Use the mounting base to mark the sheet metal, drywall, or other screw locations.
- The mounting base attaches to the bottom of the Cisco Aironet 1000 Series lightweight access point with two supplied screws, and then the assembly slides and locks onto two sheet metal, drywall, or other screws.
- When you are mounting the Cisco Aironet 1000 Series lightweight access point out from a wall (flat sides along the room or hallway), use the projection-mount L-bracket supplied with the Cisco Aironet 1000 Series lightweight access point. Use the L-bracket to mark the sheet metal, drywall, or other screw locations.
- When you are mounting the Cisco Aironet 1000 Series lightweight access point against a wall (flat Side A toward the inside of the building), use the flush-mount bracket supplied with the Cisco Aironet 1000 Series lightweight access point. The flush-mount L-bracket is the one with one long and one short leg. Use the L-bracket to mark the sheet metal, drywall, or other screw locations.

About Physical Security

Regardless of the mounting type selected, the Cisco Aironet 1000 Series lightweight access point can be secured with a Kensington MicroSaver Security Cable. If required, use any MicroSaver Security Cable to attach either side of your Cisco Aironet 1000 Series lightweight access point to a solid beam, pipe, or support.

FCC Statements for Cisco Aironet 1000 Series Lightweight Access Points

This section includes the following FCC statements for the Cisco Aironet 1000 Series lightweight access point:

- [Class A Statement](#)
- [RF Radiation Hazard Warning](#)
- [Non-Modification Statement](#)
- [Deployment Statement](#)

Class A Statement

This equipment has been tested and found to comply with the limits for a Class A digital device, pursuant to Part 15 of the FCC Rules. These limits are designed to provide reasonable protection against harmful interference when the equipment is operated in a commercial environment. This equipment generates, uses, and can radiate radio frequency energy and, if not installed and used in accordance with the instruction manual, may cause harmful interference to radio communications. Operation of this equipment in a residential area is likely to cause harmful interference in which case the user will be required to correct the interference at his own expense. [cfr reference 15.105]

RF Radiation Hazard Warning

To ensure compliance with FCC RF exposure requirements, this device must be installed in a location such that the antenna of the device will be greater than 20 cm (8 in.) from all persons. Using higher gain antennas and types of antennas not covered under the FCC certification of this product is not allowed.

Installers of the radio and end users of the Cisco Wireless LAN Solution must adhere to the installation instructions provided in this manual.

Non-Modification Statement

Use only the supplied internal antenna, or external antennas supplied by the manufacturer. Unauthorized antennas, modifications, or attachments could damage the badge and could violate FCC regulations and void the user's authority to operate the equipment.

External Antennas

The AIR-AP1020-A-K9, AIR-AP1020-E-K9, AIR-AP1020-J-K9, AIR-AP1030-A-K9, AIR-AP1030-E-K9, and AIR-AP1030-J-K9 Cisco Aironet 1000 Series IEEE 802.11a/b/g lightweight access points can be used with external antennas with the following characteristics:

- 5 GHz patch antenna: 6 dBi net gain.
- 2.4 GHz patch antenna: 6 dBi net gain.

Deployment Statement

This product is certified for indoor deployment only. Do not install or use this product outdoors.

EU Regulatory Information

Compliance Information for Cisco Aironet 1000 Series IEEE 802.11a/b/g lightweight access points:

1. Standards met:
 - Radio: EN 301 328, EN 301 893
 - EMC: EN 301489-1, EN 301 489-17
 - Safety: EN 60950
 - RF Safety: EN 50371
2. CE Marking: Cisco Aironet 1000 Series 802.11a/b/g lightweight access points are identified with this CE marker:



3. EU Country Restriction:



Note

- The Cisco Aironet 1000 Series IEEE 802.11a/b/g lightweight access point is intended for indoor use only.

- The Cisco Aironet 1000 Series IEEE 802.11a/b/g lightweight access point meets EU DFS requirement.

Generally, the 5150-5350 MHz, 5470-5750 MHz, and 2400-2483.5 MHz bands are allowed in most EU countries. However, there are several country specific restrictions that apply to different bands on a country-by-country basis.

The following entries specify countries with specific restrictions:



Note

These restrictions may evolve. It is recommended that you check with their local authorities for latest requirements

- Austria - Only transmission within the frequency band 5150-5250 MHz is allowed. The band 5470-5750 MHz is not allowed.
- Belgium - The frequency band 5470-5750 MHz is not allowed.
- France - The frequency band 5470-5750 MHz is not allowed.
- Portugal - Integral antenna is required.
- Switzerland - The frequency band 5470-5750 MHz is not allowed.
- Czech - The frequency band 5470-5750 MHz is not allowed.
- Slovak Republic - The frequency band 5470-5750 MHz is not allowed.

Industry Canada Required User Information for Cisco Aironet 1000 Series Lightweight Access Points

This device has been designed to operate with antennae having maximum gains of 7.8 dBi (2.4 GHz) and 7.4 dBi (5 GHz).

Antennae having higher gains is strictly prohibited per regulations of Industry Canada. The required antenna impedance is 50 ohms.

To reduce potential radio interference to other users, the antenna type and its gain should be so chosen that the equivalent isotropically radiated power (EIRP) is not more than that required for successful communication.

Safety Considerations



Warning

This warning symbol means danger. You are in a situation that could cause bodily injury. Before you work on any equipment, be aware of the hazards involved with electrical circuitry and be familiar with standard practices for preventing accidents. Use the statement number provided at the end of each warning to locate its translation in the translated safety warnings that accompanied this device. Statement 1071

- The AP1010, AP1020, and AP1030 Cisco Aironet 1000 Series IEEE 802.11a/b/g lightweight access points with or without external antenna ports are only intended for installation in Environment A as defined in IEEE 802.3af. All interconnected equipment must be contained within the same building including the interconnected equipment's associated LAN connections.
- For AP1020 and AP1020 Cisco Aironet 1000 Series IEEE 802.11a/b/g lightweight access points provided with optional external antenna ports, be sure that all external antennas and their associated wiring are located entirely indoors. The Cisco Aironet 1000 Series 802.11a/b/g lightweight access points and their optional external antennas are not suitable for outdoor use.
- BE SURE that plenum-mounted Cisco Aironet 1000 Series 802.11a/b/g lightweight access points are powered using PoE to comply with safety regulations.
- Suitable for use in environmental air space in accordance with Section 300.22.C of the National Electrical Code, and Sections 2-128, 12-010(3) and 12-100 of the Canadian Electrical Code, Part 1, C22.1.
- When used below dropped ceiling use a UL Listed ITE power adapter (QQGQ) marked LPS or a Listed Direct Plug-in Adapter (EPBU) marked Class 2 with output rated 48 V, 0.4 A.

**Warning**

DGT statement for products that operate at both 2.4 GHz band and 5 GHz band:

低功率電波輻射性電機管理辦法

第十四條經型式認證合格之低功率射頻電機，非經許可，公司、商號或使用者均不得擅自變更頻率、加大功率或變更原設計之特性及功能。

第十七條低功率射頻電機之使用不得影響飛航安全及干擾合法通信；經發現有干擾現象時，應立即停用，並改善至無干擾時方得繼續使用。

前項合法通信，指依電信規定作業之無線電信。低功率射頻電機須忍受合法通信或工業、科學及醫療用電波輻射性電機設備之干擾。

在5.25G ~5.35G頻帶內操作之無線資訊傳輸設備僅適於室內使用。

Warning

This equipment must be grounded. Never defeat the ground conductor or operate the equipment in the absence of a suitably installed ground conductor. Contact the appropriate electrical inspection authority or an electrician if you are uncertain that suitable grounding is available. Statement 1024

Waarschuwing

Deze apparatuur dient geaard te zijn. De aardingsleiding mag nooit buiten werking worden gesteld en de apparatuur mag nooit bediend worden zonder dat er een op de juiste wijze geïnstalleerde aardingsleiding aanwezig is. Neem contact op met de bevoegde instantie voor elektrische inspecties of met een electricien als u er niet zeker van bent dat er voor passende aarding gezorgd is.

Varoitus

Laitteiden on oltava maadoitettuja. Älä koskaan ohita maajohdinta tai käytä laitteita ilman oikein asennettua maajohdinta. Ota yhteys sähkötarkastusviranomaiseen tai sähköasentajaan, jos olet epävarma maadoituksen sopivuudesta.

- Attention** Cet équipement doit être mis à la masse. Ne jamais rendre inopérant le conducteur de masse ni utiliser l'équipement sans un conducteur de masse adéquatement installé. En cas de doute sur la mise à la masse appropriée disponible, s'adresser à l'organisme responsable de la sécurité électrique ou à un électricien.
- Warnung** Dieses Gerät muss geerdet sein. Auf keinen Fall den Erdungsleiter unwirksam machen oder das Gerät ohne einen sachgerecht installierten Erdungsleiter verwenden. Wenn Sie sich nicht sicher sind, ob eine sachgerechte Erdung vorhanden ist, wenden Sie sich an die zuständige Inspektionsbehörde oder einen Elektriker.
- Avvertenza** Questa apparecchiatura deve essere dotata di messa a terra. Non escludere mai il conduttore di protezione né usare l'apparecchiatura in assenza di un conduttore di protezione installato in modo corretto. Se non si è certi della disponibilità di un adeguato collegamento di messa a terra, richiedere un controllo elettrico presso le autorità competenti o rivolgersi a un elettricista.
- Advarsel** Dette utstyret må jordes. Omgå aldri jordingslederen og bruk aldri utstyret uten riktig montert jordingsleder. Ta kontakt med fagfolk innen elektrisk inspeksjon eller med en elektriker hvis du er usikker på om det finnes velegnet jordning.
- Aviso** Este equipamento deve ser aterrado. Nunca anule o fio terra nem opere o equipamento sem um aterramento adequadamente instalado. Em caso de dúvida com relação ao sistema de aterramento disponível, entre em contato com os serviços locais de inspeção elétrica ou um eletricista qualificado.
- ¡Advertencia!** Este equipo debe estar conectado a tierra. No inhabilite el conductor de tierra ni haga funcionar el equipo si no hay un conductor de tierra instalado correctamente. Póngase en contacto con la autoridad correspondiente de inspección eléctrica o con un electricista si no está seguro de que haya una conexión a tierra adecuada.
- Warning!** Denna utrustning måste jordas. Koppla aldrig från jordledningen och använd aldrig utrustningen utan en på lämpligt sätt installerad jordledning. Om det föreligger osäkerhet huruvida lämplig jordning finns skall elektrisk besiktningsauktoritet eller elektriker kontaktas.
- Figyelem** **A berendezés csak megfelelő védőföldeléssel működtethető. Ne iktassa ki a földelés csatlakozóját, és ne üzemeltesse a berendezést szabályosan felszerelt földelő vezeték nélkül! Ha nem biztos benne, hogy megfelelő földelés áll rendelkezésbe, forduljon a helyi elektromos hatóságokhoz vagy egy villanyszerelőhöz.**
- Предупреждение** Данное устройство должно быть заземлено. Никогда не отключайте провод заземления и не пользуйтесь оборудованием при отсутствии правильно подключенного провода заземления. За сведениями об имеющихся возможностях заземления обратитесь к соответствующим контролирующим организациям по энергоснабжению или к инженеру-электрику.

警告此设备必须接地。切勿使接地导体失效，或者在没有正确安装接地导体的情况下操作该设备。如果您不能肯定接地导体是否正
常发挥作用，请咨询有关电路检测方面的权威人士或电工。

警告この装置はアース接続する必要があります。アース導体を破損しないよう注意し、アース導体を正
しく取り付けないまま装置を稼働させないでください。アース接続が適正であるかどうか分からな
い場合には、電気検査機関または電気技術者に相談してください。



A

Alternate Method of Preparing a Version 3.0 Cisco Aironet 1000 Series [8](#)

C

Ceiling Mount Base [14](#)

Ceiling-Mount Clips [16](#)

Collecting Required Tools and Supplies [4](#)

Configuration Setup [5](#)

Conventions [v](#)

F

Flush Wall Mount [20](#)

I

Installation and Configuration [1](#)

M

Mounting the Cisco Aironet 1000 Series Lightweight Access Points [14](#)

O

Obtaining Documentation [vi](#)

Obtaining Technical Assistance [viii](#)

P

Preface [v](#)

Preparing a Version 3.0 Cisco Aironet 1000 Series Lightweight Access Point [5](#)

Preparing Mounting Locations [12](#)

Projection Wall Mount [18](#)

R

Returning MAC Information [22](#)

