



# Release Notes for Cisco Gigabit-Ethernet Optimized Video Networking Solution for Cable, Release 3.0

---

February 6, 2006

These release notes include the following topics:

- [Solution Description, page 2](#)
- [Solution Components, page 3](#)
- [Caveats, page 5](#)
- [Related Documentation, page 7](#)
- [Obtaining Documentation, page 8](#)
- [Documentation Feedback, page 9](#)
- [Cisco Product Security Overview, page 9](#)
- [Obtaining Technical Assistance, page 10](#)
- [Obtaining Additional Publications and Information, page 12](#)



Tip

---

Use this document online. This document provides hyperlinks to related documents and websites, including release notes for solution components and Cisco IOS images.

---

## Document History

Document Version	Date	Notes
1	02/06/2006	This document was first published.



---

Corporate Headquarters:  
Cisco Systems, Inc., 170 West Tasman Drive, San Jose, CA 95134-1706 USA

Copyright © 2005 Cisco Systems, Inc. All rights reserved.

# Solution Description

The Cisco Gigabit-Ethernet Optimized Video Networking Solution for Cable, Release 3.0, supports major enhancements to established video networking architectures, particularly in the areas of IP multicast (IPmc) distribution for digital broadcast video services. This release includes the addition of architectural components to support resilient IPmc forwarding over existing IP transport networks, specifically, between encoders/multiplexers and ad splicers/groomers, as well as between ad splicers (in conjunction with a video groomer function) and edge QAM devices.



Note

“Release 3.0” is used to indicate that this solution follows in the development path provided by the Cisco Gigabit-Ethernet Optimized VoD Solution, while providing support beyond VoD—for digital broadcast and digital simulcast—in a hybrid fiber coax (HFC) infrastructure.

Figure 1 illustrates the reference architecture, a subset of a large network architecture as may be developed and maintained by a multiple services operator (MSO).

Figure 1 Reference Architecture

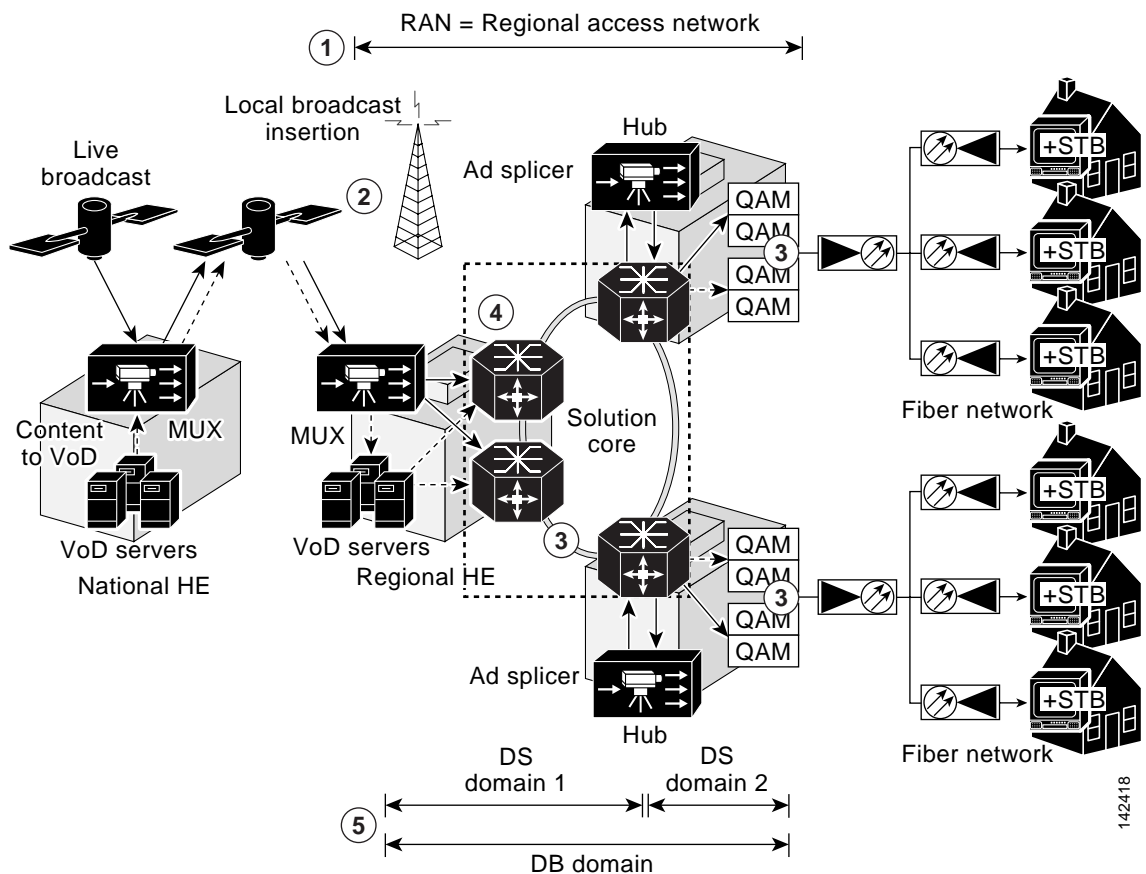

1. The focus of the solution is the regional access network (RAN), which serves a metropolitan area, and is made up of many market networks. A national headend (HE) pulls content from different sources and grooms traffic into transport streams for distribution (over satellite) to the regional headends.

142418

The solution focuses on the IP multicast (IPmc) distribution of digital simulcast (DS) and digital broadcast (DB) flows over the RAN. The solution is based on egress-replication mode for IPmc.

A single market network is depicted above. Each market network includes two access routers (ARs) in the HE, with hub routers (HRs) in the hubs. Two source routers (SRs) (not shown) aggregate services that originate in the HE.



**Note** For simplicity, only one HR is shown in each hub. There are normally two HRs in a hub, to provide redundancy.

2. Regional headends in the RAN receive content from satellite and off-air antennas.

Multiple converged regional area networks (RANs) are connected to the Internet through peering points provided by an Internet service provider. RANs can be interconnected to each other, as well as to a national HE, through a QoS-enabled backbone.

A backbone can be used to interconnect RANs as well as other MSOs. The backbone makes it possible for the MSO to migrate off the satellite links and onto terrestrial network for transport stream distribution.

3. VoD and broadcast video traffic is switched or routed onto separate DWDM paths and to separate edge QAM (EQAM) devices
4. There are multiple sources for the broadcast and VoD traffic.
5. There are effectively three broadcast IPmc domains:

Two DS domains:

- One from the regional HE multiplexer to the ad splicer/groomer in the hub
- One from the ad splicer in the hub to the EQAM devices

One DB domain—from the regional HE to the EQAM devices

Because the regional HEs are dispersed throughout the RAN/market networks, and broadcast streams from each headend are forwarded across those networks, QoS is important to the delivery of the broadcast service.

Bidirectional 10-GE links are used for broadcast video, high-speed data (HSD), and VoIP services. These interconnects may consist of several 10-GE links bonded together by means of static portchannels or Layer 3 equal-cost multipath (ECMP) load balancing.

Separate links and routing protocols are used for VoD and broadcast services. Specifically, VoD uses dedicated 10-GE interfaces that are configured with static routing.

## Solution Components

The Cisco Gigabit-Ethernet Optimized Video Networking Solution for Cable features both Cisco and third-party components. Cisco components tested, as well as third-party components used in testing, are listed in the following sections:

- [Cisco Hardware Components and Software](#)
- [Third-Party Equipment](#)

**Note**

This solution is primarily for Cisco products. To establish and maintain the third-party products and applications that may be a part of the Cisco Gigabit-Ethernet Optimized Video Networking Solution for Cable, refer to the documentation provided by the vendors of those products.

## Cisco Hardware Components and Software

The Cisco Gigabit-Ethernet Optimized Video Networking Solution for Cable, Release 3.0, consists of core Cisco components that are tested, documented, and fully supported by Cisco in the context of the solution. [Table 1](#) lists the Cisco hardware components that were tested, including the Cisco IOS Release and hardware version.

**Tip**

If you view this document online, the links in the table below provide access to the platform-specific release notes, as well as to the Cisco IOS Upgrade Planner, from which you can download the Cisco IOS images. See [How to Use the Cisco Upgrade Planner](#), below. See also [Related Documentation, page 7](#).

**Table 1** Cisco Hardware and Software Tested

Routers	Hardware	Cisco IOS Release	Hardware Version
<a href="#">Cisco 7606</a> , <a href="#">Cisco Catalyst 6509</a> <sup>1</sup>	WS-SUP720	<a href="#">Cisco IOS Release 12.2(18)SXF</a>	2.0, 2.3
	WS-SUP720-3BXL		4.3
	WS-SUP720-BASE		3.0
	WS-X6704-10GE		1.2, 2.2
	WS-X6724-SFP		2.2, 2.3
	WS-X6748-GE-TX		1.4, 2.1
	WS-F6700-DFC3A	N/A	2.1, 2.2
	WS-F6700-DFC3BXL		4.0, 5.0, 5.2
	WS-F6K-PFC3BXL		1.2, 1.6

1. See Note below.

**Note**

In this solution, the Cisco 7600 series and the Cisco Catalyst 6500 series with the same supervisor engine function identically.

## How to Use the Cisco Upgrade Planner

**Note**

You need a Cisco.com password and user ID to access the Cisco IOS Upgrade Planner.

**Step 1**

To access the Cisco IOS Upgrade Planner, complete one of the following steps:

- a. Within the online version of these release notes, click the release version in [Table 1](#), and launch the Cisco IOS Upgrade Planner.

- b. Go to <http://www.cisco.com/cgi-bin/Software/Iosplanner/Planner-tool/iosplanner.cgi?>, and launch the Cisco IOS Upgrade Planner.
- Step 2** Select the platform name from the Select Platform column in the Choose Options window.
- Step 3** Go to the Select Release column and find the heading Early Development Updates.
- Step 4** Search for the release name that is listed in [Table 1](#).
- Step 5** Click the link for that release. The Cisco IOS Upgrade Planner is refreshed.
- Step 6** Read all instructions on the page, then click the appropriate software feature in the Select Software Feature column. The Cisco IOS Upgrade Planner is refreshed.
- Step 7** Read the information on that page. If you agree with the requirements, click **I Agree**. The Cisco IOS Upgrade Planner is refreshed.

**Caution**

Make sure that you have enough memory on your system for the file. Note the values in the Minimum Memory and Minimum Flash columns in the File Download Information table.

- Step 8** Read all instructions on that page, then click the filename of the binary image in the Download: line.
- Step 9** Continue as prompted.

## Third-Party Equipment

Third-party equipment is included to test the functionality of the Cisco routers/switches used in the solution. [Table 2 on page 5](#) lists the third-party hardware and software components that were tested.

**Note**

Cisco cannot guarantee support for the third-party equipment used in the solution. While third-party components are tested for interoperability in this solution, they are not supported as part of this solution. Refer to third-party documentation for the configuration of third-party equipment.

For the most current information, contact your Cisco account representative, visit the manufacturer's website, or contact the manufacturer's representative.

**Table 2** *Third-Party Hardware and Software Tested*

Component	Vendor and Model	Software Release	Hardware Release
Multiplexer, Ad splicer/groomer	Terayon DM 6400	netcp4.1 build 16	N/A
	BigBand BMR1200	suite 2.11.1	
Edge QAM device	Motorola SEM v8	6.1.1	

## Caveats

This section lists the key caveats for the components in this solution. Workarounds are provided where applicable.

**Note**

For additional caveats that may affect this solution, refer to the release notes for each platform and software release that you use as a solution component.

If you have an account with Cisco.com, you can use the Bug Toolkit to find to find caveats of any severity for any release. To find the open caveats for Cisco components used in this solution, you must query the system for each of the component and software releases used or being planned for your network. To reach the Bug Toolkit, go to [http://www.cisco.com/cgi-bin/Support/Bugtool/launch\\_bugtool.pl](http://www.cisco.com/cgi-bin/Support/Bugtool/launch_bugtool.pl).

## Open Caveats—Release 3.0

- CSCsc78272  
On occasion, when an interface goes into a shutdown state on a Cisco 7600 series router, duplicate multicast packets may be sent out on other interfaces.  
*Workaround:* There is no workaround.
- CSCsc62786  
When a XENPAK with one fiber for unidirectional flows is removed, the interface state remains up.  
*Workaround:* There is no workaround.
- CSCsc64639  
When traffic is sent across a port channel of a Cisco 7600 series router and the **show interface port-channel** command is issued, the TX and RX load counters for the interface show as permanently set to 0.  
*Workaround:* Look further into the results of the **show interface port-channel command** and use the *bits/sec* or *packets/sec* output to calculate the line rate.
- CSCsc70383  
On occasion, shutting an interface can cause a Cisco 7600 series router to produce continuous tracebacks.  
*Workaround:* Reload the router.
- CSCsc76240  
On occasion, an accounting record may be dropped because of a low memory error (%AAA-3-DROPACCTLOWMEM) generated during multiple user loads.  
Ten users were simultaneously performing actions on the router. The memory usage observed following a **show process memory** command shows plenty of memory available.  
*Workaround:* There is no workaround.
- CSCsc79295, CSCsb34180  
An SNMP walk on a Cisco 7600 series router never fully executes.  
It hangs because OIDs seem to be out of order when hitting  
SNMPv2-SMI::mib-2.47.1.3.3.1.1.20.27 = INTEGER: 27 before  
SNMPv2-SMI::mib-2.47.1.3.3.1.1.20.23 = INTEGER: 23.  
*Workaround:* There is no workaround.
- CSCsc86567  
On occasion, on a Cisco 7600 series router, SNMP stops responding following a reload.

Multiple reloads cause SNMP to stop responding, and generate a traceback.

*Workaround:* Reload the router again.

- CSCsc86579

On a Cisco 7600 series router, multicast replication mode configured as ingress changes to egress following a reload of the router.

*Workaround:* Remove the **no mls ip multicast replication-mode ingress** command, then add the **mls ip multicast replication-mode ingress** command.

- CSCsc13244

When a fiber GBIC is inserted and a copper GBIC replaces it, the **speed nonegotiate** command does not apply to the copper GBIC and prevents the link from coming up. The command remains in the configuration.

*Workaround:* Remove the **speed nonegotiate** command.

## Related Documentation

### Solution Documentation

This document, and the *Cisco Gigabit-Ethernet Optimized Video Networking Solution for Cable Design and Implementation Guide, Release 3.0*, are available under the following URL:

<http://www.cisco.com/univercd/cc/td/doc/solution/vodsols/index.htm>

### Cisco 7600 Series Routers

Documentation resources for Cisco 7600 series routers are available at the following URL:

- Cisco 7600 Series Router

<http://www.cisco.com/univercd/cc/td/doc/product/core/cis7600/index.htm>

- Cisco 7600 Series Router Cisco IOS SW Documentation, 12.2SX

<http://www.cisco.com/univercd/cc/td/doc/product/core/cis7600/software/122sx/index.htm>

### Cisco Catalyst 6500 Series Switches

Documentation resources for the Cisco 6500 series switches are available at the following URL:

- Catalyst 6500 Series Switches

<http://www.cisco.com/univercd/cc/td/doc/product/lan/cat6000/index.htm>

- Catalyst 6500 Series Cisco IOS Software Documentation, 12.2SX

<http://www.cisco.com/univercd/cc/td/doc/product/lan/cat6000/122sx/index.htm>

# Obtaining Documentation

Cisco documentation and additional literature are available on Cisco.com. Cisco also provides several ways to obtain technical assistance and other technical resources. These sections explain how to obtain technical information from Cisco Systems.

## Cisco.com

You can access the most current Cisco documentation at this URL:

<http://www.cisco.com/techsupport>

You can access the Cisco website at this URL:

<http://www.cisco.com>

You can access international Cisco websites at this URL:

[http://www.cisco.com/public/countries\\_languages.shtml](http://www.cisco.com/public/countries_languages.shtml)

## Product Documentation DVD

Cisco documentation and additional literature are available in the Product Documentation DVD package, which may have shipped with your product. The Product Documentation DVD is updated regularly and may be more current than printed documentation.

The Product Documentation DVD is a comprehensive library of technical product documentation on portable media. The DVD enables you to access multiple versions of hardware and software installation, configuration, and command guides for Cisco products and to view technical documentation in HTML. With the DVD, you have access to the same documentation that is found on the Cisco website without being connected to the Internet. Certain products also have .pdf versions of the documentation available.

The Product Documentation DVD is available as a single unit or as a subscription. Registered Cisco.com users (Cisco direct customers) can order a Product Documentation DVD (product number DOC-DOCDVD=) from the Ordering tool or Cisco Marketplace.

Cisco Ordering tool:

<http://www.cisco.com/en/US/partner/ordering/>

Cisco Marketplace:

<http://www.cisco.com/go/marketplace/>

## Ordering Documentation

Beginning June 30, 2005, registered Cisco.com users may order Cisco documentation at the Product Documentation Store in the Cisco Marketplace at this URL:

<http://www.cisco.com/go/marketplace/>

Cisco will continue to support documentation orders using the Ordering tool:

- Registered Cisco.com users (Cisco direct customers) can order documentation from the Ordering tool:

<http://www.cisco.com/en/US/partner/ordering/>



- Instructions for ordering documentation using the Ordering tool are at this URL:  
[http://www.cisco.com/univercd/cc/td/doc/es\\_inpk/pdi.htm](http://www.cisco.com/univercd/cc/td/doc/es_inpk/pdi.htm)
- Nonregistered Cisco.com users can order documentation through a local account representative by calling Cisco Systems Corporate Headquarters (California, USA) at 408 526-7208 or, elsewhere in North America, by calling 1 800 553-NETS (6387).

## Documentation Feedback

You can rate and provide feedback about Cisco technical documents by completing the online feedback form that appears with the technical documents on Cisco.com.

You can send comments about Cisco documentation to [bug-doc@cisco.com](mailto:bug-doc@cisco.com).

You can submit comments by using the response card (if present) behind the front cover of your document or by writing to the following address:

Cisco Systems  
Attn: Customer Document Ordering  
170 West Tasman Drive  
San Jose, CA 95134-9883

We appreciate your comments.

## Cisco Product Security Overview

Cisco provides a free online Security Vulnerability Policy portal at this URL:

[http://www.cisco.com/en/US/products/products\\_security\\_vulnerability\\_policy.html](http://www.cisco.com/en/US/products/products_security_vulnerability_policy.html)

From this site, you can perform these tasks:

- Report security vulnerabilities in Cisco products.
- Obtain assistance with security incidents that involve Cisco products.
- Register to receive security information from Cisco.

A current list of security advisories and notices for Cisco products is available at this URL:

<http://www.cisco.com/go/psirt>

If you prefer to see advisories and notices as they are updated in real time, you can access a Product Security Incident Response Team Really Simple Syndication (PSIRT RSS) feed from this URL:

[http://www.cisco.com/en/US/products/products\\_psirt\\_rss\\_feed.html](http://www.cisco.com/en/US/products/products_psirt_rss_feed.html)

## Reporting Security Problems in Cisco Products

Cisco is committed to delivering secure products. We test our products internally before we release them, and we strive to correct all vulnerabilities quickly. If you think that you might have identified a vulnerability in a Cisco product, contact PSIRT:

- Emergencies—[security-alert@cisco.com](mailto:security-alert@cisco.com)

An emergency is either a condition in which a system is under active attack or a condition for which a severe and urgent security vulnerability should be reported. All other conditions are considered nonemergencies.

- Nonemergencies—[psirt@cisco.com](mailto:psirt@cisco.com)

In an emergency, you can also reach PSIRT by telephone:

- 1 877 228-7302
- 1 408 525-6532



Tip

---

We encourage you to use Pretty Good Privacy (PGP) or a compatible product to encrypt any sensitive information that you send to Cisco. PSIRT can work from encrypted information that is compatible with PGP versions 2.x through 8.x.

Never use a revoked or an expired encryption key. The correct public key to use in your correspondence with PSIRT is the one linked in the Contact Summary section of the Security Vulnerability Policy page at this URL:

[http://www.cisco.com/en/US/products/products\\_security\\_vulnerability\\_policy.htm](http://www.cisco.com/en/US/products/products_security_vulnerability_policy.htm)

The link on this page has the current PGP key ID in use.

---

## Obtaining Technical Assistance

Cisco Technical Support provides 24-hour-a-day award-winning technical assistance. The Cisco Technical Support & Documentation website on Cisco.com features extensive online support resources. In addition, if you have a valid Cisco service contract, Cisco Technical Assistance Center (TAC) engineers provide telephone support. If you do not have a valid Cisco service contract, contact your reseller.

## Cisco Technical Support & Documentation Website

The Cisco Technical Support & Documentation website provides online documents and tools for troubleshooting and resolving technical issues with Cisco products and technologies. The website is available 24 hours a day, at this URL:

<http://www.cisco.com/techsupport>

Access to all tools on the Cisco Technical Support & Documentation website requires a Cisco.com user ID and password. If you have a valid service contract but do not have a user ID or password, you can register at this URL:

<http://tools.cisco.com/RPF/register/register.do>

**Note**

Use the Cisco Product Identification (CPI) tool to locate your product serial number before submitting a web or phone request for service. You can access the CPI tool from the Cisco Technical Support & Documentation website by clicking the **Tools & Resources** link under Documentation & Tools. Choose **Cisco Product Identification Tool** from the Alphabetical Index drop-down list, or click the **Cisco Product Identification Tool** link under Alerts & RMAs. The CPI tool offers three search options: by product ID or model name; by tree view; or for certain products, by copying and pasting **show** command output. Search results show an illustration of your product with the serial number label location highlighted. Locate the serial number label on your product and record the information before placing a service call.

## Submitting a Service Request

Using the online TAC Service Request Tool is the fastest way to open S3 and S4 service requests. (S3 and S4 service requests are those in which your network is minimally impaired or for which you require product information.) After you describe your situation, the TAC Service Request Tool provides recommended solutions. If your issue is not resolved using the recommended resources, your service request is assigned to a Cisco engineer. The TAC Service Request Tool is located at this URL:

<http://www.cisco.com/techsupport/servicerequest>

For S1 or S2 service requests or if you do not have Internet access, contact the Cisco TAC by telephone. (S1 or S2 service requests are those in which your production network is down or severely degraded.) Cisco engineers are assigned immediately to S1 and S2 service requests to help keep your business operations running smoothly.

To open a service request by telephone, use one of the following numbers:

Asia-Pacific: +61 2 8446 7411 (Australia: 1 800 805 227)

EMEA: +32 2 704 55 55

USA: 1 800 553-2447

For a complete list of Cisco TAC contacts, go to this URL:

<http://www.cisco.com/techsupport/contacts>

## Definitions of Service Request Severity

To ensure that all service requests are reported in a standard format, Cisco has established severity definitions.

**Severity 1 (S1)**—Your network is “down,” or there is a critical impact to your business operations. You and Cisco will commit all necessary resources around the clock to resolve the situation.

**Severity 2 (S2)**—Operation of an existing network is severely degraded, or significant aspects of your business operation are negatively affected by inadequate performance of Cisco products. You and Cisco will commit full-time resources during normal business hours to resolve the situation.

**Severity 3 (S3)**—Operational performance of your network is impaired, but most business operations remain functional. You and Cisco will commit resources during normal business hours to restore service to satisfactory levels.

**Severity 4 (S4)**—You require information or assistance with Cisco product capabilities, installation, or configuration. There is little or no effect on your business operations.

# Obtaining Additional Publications and Information

Information about Cisco products, technologies, and network solutions is available from various online and printed sources.

- Cisco Marketplace provides a variety of Cisco books, reference guides, documentation, and logo merchandise. Visit Cisco Marketplace, the company store, at this URL:  
<http://www.cisco.com/go/marketplace/>
- *Cisco Press* publishes a wide range of general networking, training and certification titles. Both new and experienced users will benefit from these publications. For current Cisco Press titles and other information, go to Cisco Press at this URL:  
<http://www.ciscopress.com>
- *Packet* magazine is the Cisco Systems technical user magazine for maximizing Internet and networking investments. Each quarter, Packet delivers coverage of the latest industry trends, technology breakthroughs, and Cisco products and solutions, as well as network deployment and troubleshooting tips, configuration examples, customer case studies, certification and training information, and links to scores of in-depth online resources. You can access Packet magazine at this URL:  
<http://www.cisco.com/packet>
- *iQ Magazine* is the quarterly publication from Cisco Systems designed to help growing companies learn how they can use technology to increase revenue, streamline their business, and expand services. The publication identifies the challenges facing these companies and the technologies to help solve them, using real-world case studies and business strategies to help readers make sound technology investment decisions. You can access iQ Magazine at this URL:  
<http://www.cisco.com/go/iqmagazine>  
or view the digital edition at this URL:  
<http://ciscoiq.texterity.com/ciscoiq/sample/>
- *Internet Protocol Journal* is a quarterly journal published by Cisco Systems for engineering professionals involved in designing, developing, and operating public and private internets and intranets. You can access the Internet Protocol Journal at this URL:  
<http://www.cisco.com/ipj>
- Networking products offered by Cisco Systems, as well as customer support services, can be obtained at this URL:  
<http://www.cisco.com/en/US/products/index.html>
- Networking Professionals Connection is an interactive website for networking professionals to share questions, suggestions, and information about networking products and technologies with Cisco experts and other networking professionals. Join a discussion at this URL:  
<http://www.cisco.com/discuss/networking>
- World-class networking training is available from Cisco. You can view current offerings at this URL:  
<http://www.cisco.com/en/US/learning/index.html>

---

This document is to be used in conjunction with the documents listed in [Related Documentation, page 7](#).

CCSP, CCVP, the Cisco Square Bridge logo, Follow Me Browsing, and StackWise are trademarks of Cisco Systems, Inc.; Changing the Way We Work, Live, Play, and Learn, and iQuick Study are service marks of Cisco Systems, Inc.; and Access Registrar, Aironet, BPX, Catalyst, CCDA, CCDP, CCIE, CCIP, CCNA, CCNP, Cisco, the Cisco Certified Internetwork Expert logo, Cisco IOS, Cisco Press, Cisco Systems, Cisco Systems Capital, the Cisco Systems logo, Cisco Unity, Enterprise/Solver, EtherChannel, EtherFast, EtherSwitch, Fast Step, FormShare, GigaDrive, GigaStack, HomeLink, Internet Quotient, IOS, IP/TV, iQ Expertise, the iQ logo, iQ Net Readiness Scorecard, LightStream, Linksys, MeetingPlace, MGX, the Networkers logo, Networking Academy, Network Registrar, *Packet*, PIX, Post-Routing, Pre-Routing, ProConnect, RateMUX, ScriptShare, SlideCast, SMARTnet, The Fastest Way to Increase Your Internet Quotient, and TransPath are registered trademarks of Cisco Systems, Inc. and/or its affiliates in the United States and certain other countries.

All other trademarks mentioned in this document or Website are the property of their respective owners. The use of the word partner does not imply a partnership relationship between Cisco and any other company. (0601R)

© 2006 Cisco Systems, Inc. All rights reserved.

